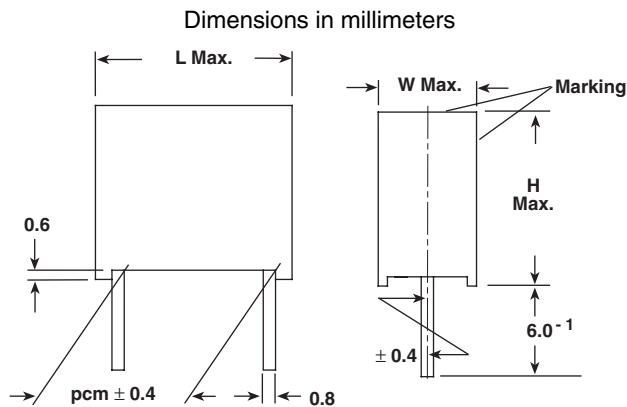

Metallized Polycarbonate Film Capacitor

Related Document: IEC 60384-6

MAIN APPLICATIONS

Storage, filter, timing and integrating circuits.

MARKING

Manufacturer's logo/type/C-value/rated voltage/tolerance/date of manufacture

DIELECTRIC

Polycarbonate film

ELECTRODES

Vacuum deposited aluminum

COATING

Flame retardant plastic case (UL-class 94 V-0), red, epoxy resin sealed

CONSTRUCTION

Extended metallized film (refer to general information)

LEADS

Tinned wire

IEC TEST CLASSIFICATION

55/100/56, according to IEC 60068

OPERATING TEMPERATURE RANGE

- 55°C to + 100°C

CAPACITANCE TOLERANCES

± 20% (M), ± 10% (K), ± 5% (J)

RATED VOLTAGES (U_R)

63 VDC, 100 VDC, 250 VDC, 400 VDC

MAXIMUM PULSE RISE TIME

PCM (mm)	Maximum Pulse Rise Time d_v/d_t [V/ μ s]			
	63 VDC	100 VDC	250 VDC	400 VDC
10	17	23	38	61
15	9	13	21	33
22.5	6	8	13	20
27.5	5	6	10	16

 If the maximum pulse voltage is less than the rated voltage higher d_v/d_t values can be permitted.

FEATURES

 Product is completely lead (Pb)-free.
 Product is RoHS compliant.

DERATING FOR DC AND AC. CATEGORY VOLTAGE U_C

 At + 85°C: $U_C = 1.0 U_R$
 At + 100°C: $U_C = 0.8 U_R$

CAPACITANCE RANGE

 0.01 μ F to 10 μ F

RoHS
 COMPLIANT

PERMISSIBLE AC VOLTAGES (RMS) UP TO 60HZ

40 VAC, 63 VAC, 160 VAC, 200 VAC

TEST VOLTAGE (ELECTRODE/ELECTRODE)

 1.6 x U_R for 2 s

INSULATION RESISTANCE

Measured at 100 VDC (63 VDC series measured at 50 VDC) after one minute

For $C \leq 0.33\mu$ F and $U_R > 100$ VDC:

 30,000 M Ω minimum value (100,000 M Ω typical value)

For $C \leq 0.33\mu$ F and $U_R \leq 100$ VDC:

 15,000 M Ω minimum value (50,000 M Ω typical value)

TIME CONSTANT

Measured at 100 VDC (63 VDC series measured at 50 VDC) after one minute

For $C > 0.33\mu$ F and $U_R > 100$ VDC:

10,000 s minimum value (40,000 s typical value)

For $C > 0.33\mu$ F and $U_R \leq 100$ VDC:

5000 s minimum value (15,000 s typical value)

CAPACITANCE DRIFT

Up to + 40°C, ± 1% for a period of two years

SELF INDUCTANCE

~ 6 nH measured with 2mm long leads

PULL TEST ON LEADS

≥ 30 N in direction of leads according to IEC 60068-2-21

BEND TEST ON LEADS

2 bends through 90° with half of the force used in pull test

RELIABILITY

Operational life > 300,000 h

 Failure rate < 1 FIT (40°C and 0.5 x U_R)

 For further details, please refer to the general information available at www.vishay.com/doc?26033.



DISSIPATION FACTOR TAN δ

MEASURED AT	$C \leq 0.1\mu\text{F}$	$0.1\mu\text{F} < C \leq 1.0\mu\text{F}$	$C > 1.0\mu\text{F}$
1kHz	3×10^{-3}	3×10^{-3}	3×10^{-3}
10kHz	4×10^{-3}	4×10^{-3}	—
100kHz	10×10^{-3}	—	—
Maximum values			

CAPACITANCE	CAPACITANCE CODE	VOLTAGE CODE 06 63 VDC/40 VAC				VOLTAGE CODE 01 100 VDC/63 VAC				VOLTAGE CODE 25 250 VDC/160 VAC				VOLTAGE CODE 40 400 VDC/200 VAC			
		W	H	L	PCM	W	H	L	PCM	W	H	L	PCM	W	H	L	PCM
0.01 μF	- 310	—	—	—	—	—	—	—	—	—	—	—	—	4.0	9.0	13.0	10
0.015 μF	- 315	—	—	—	—	—	—	—	—	—	—	—	—	4.0	9.0	13.0	10
0.022 μF	- 322	—	—	—	—	—	—	—	—	4.0	9.0	13.0	10	4.0	9.0	13.0	10
0.033 μF	- 333	—	—	—	—	—	—	—	—	4.0	9.0	13.0	10	5.5	10.5	13.0	10
0.047 μF	- 347	—	—	—	—	—	—	—	—	4.0	9.0	13.0	10	5.5	10.5	18.0	15
0.068 μF	- 368	—	—	—	—	4.0	9.0	13.0	10	5.5	10.5	13.0	10	5.5	10.5	18.0	15
0.1 μF	- 410	—	—	—	—	4.0	9.0	13.0	10	5.5	10.5	18.0	15	6.5	12.5	18.0	15
0.15 μF	- 415	—	—	—	—	5.5	10.5	13.0	10	5.5	10.5	18.0	15	8.5	14.5	18.0	15
0.22 μF	- 422	4.0	9.0	13.0	10	6.5	11.5	13.0	10	6.5	12.5	18.0	15	7.5	15.5	26.5	22.5
0.33 μF	- 433	4.5	9.5	13.0	10	5.5	10.5	18.0	15	7.5	13.5	18.0	15	8.5	16.5	26.5	22.5
0.47 μF	- 447	5.5	10.5	13.0	10	6.5	12.5	18.0	15	7.5	15.5	26.5	22.5	10.5	18.5	26.5	22.5
0.68 μF	- 468	5.5	10.5	18.0	15	7.5	13.5	18.0	15	8.5	16.5	26.5	22.5	11.5	20.5	31.5	27.5
1.0 μF	- 510	6.5	12.5	18.0	15	8.5	14.5	18.0	15	8.5	16.5	26.5	22.5	13.5	23.5	31.5	27.5
1.5 μF	- 515	7.5	13.5	18.0	15	7.5	15.5	26.5	22.5	11.5	20.5	31.5	27.5	—	—	—	—
2.2 μF	- 522	8.5	14.5	18.0	15	8.5	16.5	26.5	22.5	11.5	20.5	31.5	27.5	—	—	—	—
3.3 μF	- 533	7.5	15.5	26.5	22.5	10.5	18.5	26.5	22.5	13.5	23.5	31.5	27.5	—	—	—	—
4.7 μF	- 547	8.5	16.5	26.5	22.5	11.5	20.5	31.5	27.5	16.5	29.5	31.5	27.5	—	—	—	—
6.8 μF	- 568	10.5	18.5	26.5	22.5	13.5	23.5	31.5	27.5	—	—	—	—	—	—	—	—
10.0 μF	- 610	11.5	20.5	31.5	27.5	15.0	24.5	31.5	27.5	—	—	—	—	—	—	—	—

Further C-values upon request

RECOMMENDED PACKAGING

LETTER CODE	TYPE OF PACKAGING	HEIGHT (H) (mm)	REEL DIAMETER (mm)	ORDERING CODE EXAMPLES	PCM 10	PCM 15	PCM 22.5 - 27.5
D	AMMO	16.5	S*	MKC 1862-310/405-D	X	X	—
G	AMMO	18.5	S*	MKC 1862-310/405-G	X	X	—
F	REEL	16.5	350	MKC 1862-310/405-F	X	X	—
W	REEL	18.5	350	MKC 1862-310/405-W	X	X	—
V	REEL	18.5	500	MKC 1862-522/255-V	—	X	X
G	AMMO	18.5	L*	MKC 1862-522/255-G	—	—	X
—	BULK	—	—	MKC 1862-522/255	X	X	X

*S - box size 55 x 210 x 340mm (W x H x L)

*L - box size 60 x 360 x 510mm (W x H x L)

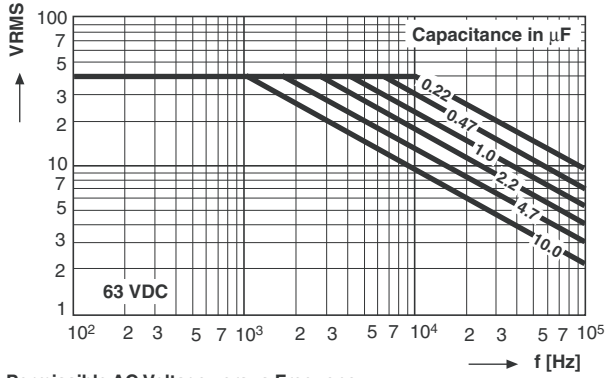

Permissible AC Voltage versus Frequency

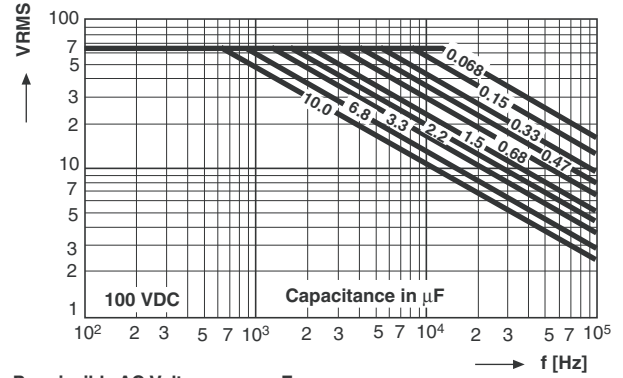

Permissible AC Voltage versus Frequency

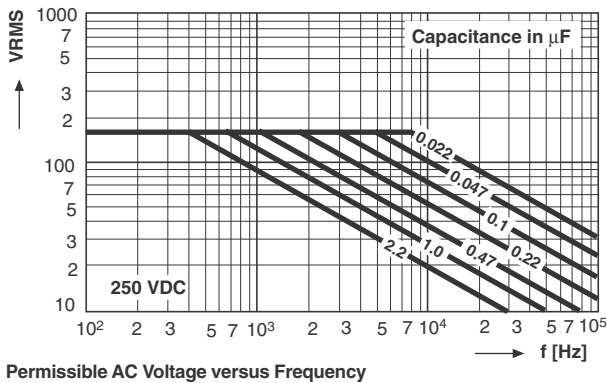

Permissible AC Voltage versus Frequency

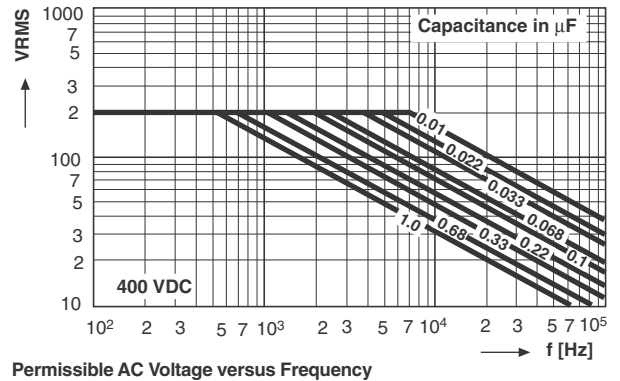

Permissible AC Voltage versus Frequency

