

Solid Aluminum Capacitors with Organic Semiconductor Electrolyte

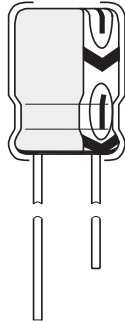

Fig.1 Component outline.

FEATURES

- High capacity, low ESR. Approximately two times the capacitance of existing capacitors and less than half the ESR.
- 94SP capacitors are ideal for designing around MPU's for computer equipment.

PART MARKING

 Sleeve color: Blue. Marking: White

- Polarity -
- Rated voltage
- Capacitance
- Vishay OS-CON
- Lot number
- Type
- Maximum operating temperature (+ 105 °C)

QUICK REFERENCE DATA			
DESCRIPTION	VALUE		
Operating Temperature Range	- 55 °C to + 105 °C		
Capacitance Tolerance at 120 Hz	X0 = ± 20 %		
Tangent of Loss Angle (tan δ) at 120 Hz	≤ Values in Standard Ratings Table		
Maximum Leakage Current (μA/2 minutes)(or less)*	0.1 CV		
Equivalent Series Resistance (Ω), (100 k to 300 kHz)	≤ Values in Standard Ratings Table		
Temperature Characteristics Impedance Ratio at 100 kHz	- 55 °C	Z/Z _{20 °C}	1.0 to 1.25
	+ 105 °C	Z/Z _{20 °C}	0.75 to 1.0
High Temperature Load (+ 105 °C, 1000 hours) Rated Voltage Applied	ΔC/C	Within ± 20 % of the initial value	
	tan δ	≤ 1.5 x the value of Tangent of Loss Angle	
	Leakage Current	≤ The Value of Max. Leakage Current	
Moisture Resistance (+ 60 °C, 90 to 95 % RH, 1000 hours, no voltage)	ΔC/C	Within ± 20 % of the initial value	
	tan δ	≤ 2 x the value of Tangent of Loss Angle	
	Leakage Current	≤ The Value of Max. Leakage Current	
Reverse Voltage Guarantee	Temporary: < 20 % of the rated voltage Continuous: < 10 % of the rated voltage		

* If any doubt arises, measure the current after applying voltage (voltage treatment) for 30 minutes at + 105 °C. The rated voltage should be applied for all WV.

TEMPERATURE COEFFICIENT RIPPLE CURRENT	
Ambient Temperature	Coefficient
~ + 45 °C	1.0
+ 85 °C	0.7
+ 95 °C	0.4
+ 105 °C	0.25

DIMENSIONS in inches [millimeters]					
CASE CODE	NOMINAL CASE SIZE ∅ D x L	F	∅ d	G (Max.)	K (Max.)
C'	0.248 x 0.197 [6.3 x 5.0]	0.098 ± 0.020 [2.5 ± 0.5]	0.024 [0.6]	0.020 [0.5]	0.020 [0.5]
E'	0.315 x 0.197 [8.0 x 5.0]	0.138 ± 0.020 [3.5 ± 0.5]	0.024 [0.6]	0.031 [0.8]	0.031 [0.8]
F'	0.394 x 0.197 [10.0 x 5.0]	0.197 ± 0.020 [5.0 ± 0.5]	0.024 [0.6]	0.031 [0.8]	0.031 [0.8]
C	0.248 x 0.268 [6.3 x 6.8]	0.098 ± 0.020 [2.5 ± 0.5]	0.024 [0.6]	0.020 [0.5]	0.020 [0.5]
E	0.315 x 0.413 [8.0 x 10.5]	0.138 ± 0.020 [3.5 ± 0.5]	0.024 [0.6]	0.031 [0.8]	0.031 [0.8]
F	0.394 x 0.413 [10.0 x 10.5]	0.197 ± 0.020 [5.0 ± 0.5]	0.024 [0.6]	0.031 [0.8]	0.031 [0.8]
F ₀	0.394 x 0.787 [10.0 x 20.0]	0.197 ± 0.020 [5.0 ± 0.5]	0.031 [0.8]	0.031 [0.8]	0.031 [0.8]
F	0.492 x 0.866 [12.5 x 22.0]	0.197 ± 0.040 [5.0 ± 1.0]	0.031 [0.8]	0.031 [0.8]	0.031 [0.8]

DIMENSIONS in inches [millimeters]

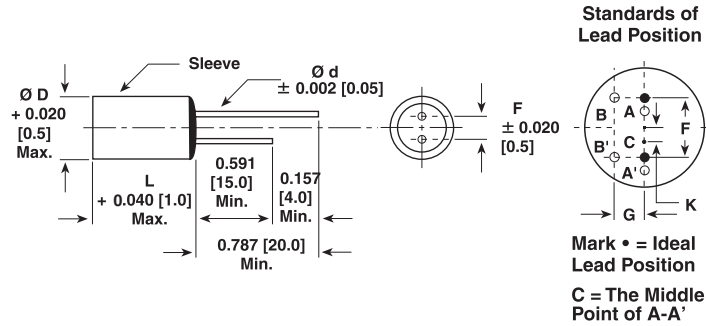

CASE CODE LIST						
CAPACITANCE (μ F)	WV* (SV)**	4 (5.2)	6.3 (8.2)	10 (11.5)	16 (18.4)	20 (23)
22.0		-	-	-	-	(C')
33.0		-	-	-	C'	C
47.0		-	-	-	(C)	(E')
56.0		-	-	(C')	-	-
68.0		-	C'	-	(E')	(F')
82.0		-	-	C	-	-
100.0		C'	-	(E')	(F')	-
120.0		(C)	C	-	-	(E)
150.0		-	E'	-	-	-
180.0		-	-	F'	(E)	F
220.0		E'	F'	-	-	-
270.0		-	-	(E)	(F)	-
330.0		F'	-	-	-	-
390.0		-	E	-	-	-
470.0		-	-	(F)	-	-
560.0		E	-	-	-	-
680.0		-	F	-	-	-
820.0		F	-	-	-	-
1500.0		(F ₀)	-	-	-	-
2200.0		G	-	-	-	-

*WV = Rated Voltage. **(SV) = Surge Voltage (at room temperature).

STANDARD RATINGS							
CASE CODE	PART NUMBER*	RATED VOLTAGE (V)	NOMINAL CAPACITANCE (μ F)	ALLOWABLE RIPPLE CURRENT (mAmps) at 100 kHz, + 45 °C	MAX. LEAKAGE CURRENT (μ A) (After 2 Minutes)	MAX. TANGENT OF LOSS ANGLE	MAX. ESR 100 k to 300 kHz (m Ω)
C'	94SP226X0020CBP	20.0	22.0	1580	44.00	0.06	50
	94SP336X0016CBP	16.0	33.0	1580	52.80	0.06	50
	94SP566X0010CBP	10.0	56.0	1710	56.00	0.06	45
	94SP686X06R3CBP	6.3	68.0	1850	42.84	0.06	40
	94SP107X0004CBP	4.0	100.0	1850	40.00	0.06	40
E'	94SP476X0020EBP	20.0	47.0	2210	94.00	0.07	36
	94SP686X0016EBP	16.0	68.0	2280	108.80	0.07	34
	94SP107X0010EBP	10.0	100.0	2350	100.00	0.07	32
	94SP157X06R3EBP	6.3	150.0	2420	94.50	0.07	30
	94SP227X0004EBP	4.0	220.0	2510	88.00	0.07	28

*Part Numbers shown are for $\pm 20\%$ capacitance tolerance (X0).

94SP107X0016... Part Number is complete with Case Code and 2 character Package or Process Code. BP as shown indicates Bulk Pack.



STANDARD RATINGS							
CASE CODE	PART NUMBER*	RATED VOLTAGE (V)	NOMINAL CAPACITANCE (μF)	ALLOWABLE RIPPLE CURRENT (mAmps) at 100 kHz, + 45 °C	MAX. LEAKAGE CURRENT (μA) (After 2 Minutes)	MAX. TANGENT OF LOSS ANGLE	MAX. ESR 100 k to 300 kHz (mΩ)
F'	94SP686X0020FBP	20.0	68.0	2800	136.00	0.07	34
	94SP107X0016FBP	16.0	100.0	2890	160.00	0.07	32
	94SP187X0010FBP	10.0	180.0	2990	180.00	0.07	30
	94SP227X06R3FBP	6.3	220.0	3100	138.60	0.07	28
	94SP337X0004FBP	4.0	330.0	3230	132.00	0.07	24
C	94SP336X0020CBP	20.0	33.0	1710	66.00	0.07	45
	94SP476X0016CBP	16.0	47.0	1710	75.20	0.07	45
	94SP826X0010CBP	10.0	82.0	1850	82.00	0.07	40
	94SP127X06R3CBP	6.3	120.0	1930	75.60	0.07	35
	94SP157X0004CBP	4.0	120.0	1930	60.00	0.07	35
E	94SP127X0020EBP	20.0	120.0	3110	200.00	0.08	24
	94SP187X0016EBP	16.0	180.0	3410	288.00	0.08	20
	94SP277X0010EBP	10.0	270.0	3600	270.00	0.08	18
	94SP397X06R3EBP	6.3	390.0	3810	245.70	0.08	16
	94SP567X0004EBP	4.0	560.0	4080	224.00	0.08	14
F	94SP187X0020FBP	20.0	180.0	4280	360.00	0.08	20
	94SP277X0016FBP	16.0	270.0	4400	432.00	0.08	18
	94SP477X0010FBP	10.0	470.0	4510	470.00	0.08	15
	94SP687X06R3FBP	6.3	680.0	4840	428.40	0.08	13
	94SP827X0004FBP	4.0	820.0	5040	328.00	0.08	12
F ₀	94SP158X0004FBP	4.0	1500.0	6500	600.00	0.10	10
G	94SP228X0004GBP	4.0	2200.0	7100	880.00	0.12	10

*Part Numbers shown are for $\pm 20\%$ capacitance tolerance (X0).

94SP107X0016... Part Number is complete with Case Code and 2 character Package or Process Code. BP as shown indicates Bulk Pack.