

**INA103**

## Low Noise, Low Distortion INSTRUMENTATION AMPLIFIER

### FEATURES

- **LOW NOISE:**  $1\text{nV}/\sqrt{\text{Hz}}$
- **LOW THD+N:** 0.0009% at 1kHz,  $G = 100$
- **HIGH GBW:** 100MHz at  $G = 1000$
- **WIDE SUPPLY RANGE:**  $\pm 9\text{V}$  to  $\pm 25\text{V}$
- **HIGH CMRR:**  $>100\text{dB}$
- **BUILT-IN GAIN SETTING RESISTORS:**  
 $G = 1, 100$
- **UPGRADES AD625**

### APPLICATIONS

- **HIGH QUALITY MICROPHONE PREAMPS (REPLACES TRANSFORMERS)**
- **MOVING-COIL PREAMPLIFIERS**
- **DIFFERENTIAL RECEIVERS**
- **AMPLIFICATION OF SIGNALS FROM:**  
Strain Gages (Weigh Scale Applications)  
Thermocouples  
Bridge Transducers

### DESCRIPTION

The INA103 is a very low noise, low distortion monolithic instrumentation amplifier. Its current-feedback circuitry achieves very wide bandwidth and excellent dynamic response. It is ideal for low-level audio signals such as balanced low-impedance microphones. The INA103 provides near-theoretical limit noise performance for  $200\Omega$  source impedances. Many industrial applications also benefit from its low noise and wide bandwidth.

Unique distortion cancellation circuitry reduces distortion to extremely low levels, even in high gain. Its balanced input, low noise and low distortion provide superior performance compared to transformer-coupled microphone amplifiers used in professional audio equipment.

The INA103's wide supply voltage ( $\pm 9$  to  $\pm 25\text{V}$ ) and high output current drive allow its use in high-level audio stages as well. A copper lead frame in the plastic DIP assures excellent thermal performance.

The INA103 is available in 16-pin plastic DIP and SOL-16 surface-mount packages. Commercial and Industrial temperature range models are available.

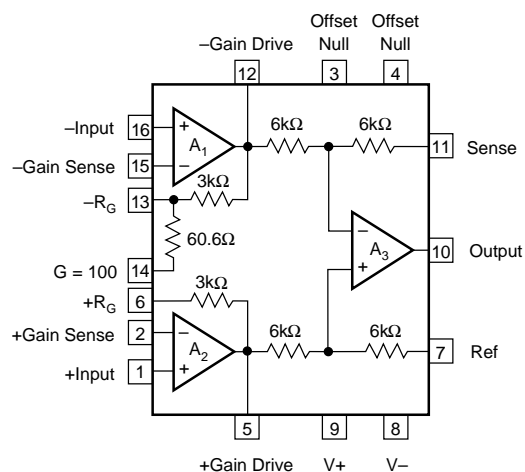

# SPECIFICATIONS

All specifications at  $T_A = +25^\circ\text{C}$ ,  $V_S = \pm 15\text{V}$  and  $R_L = 2\text{k}\Omega$ , unless otherwise noted.

PARAMETER	CONDITIONS	INA103KP, KU			UNITS
		MIN	TYP	MAX	
<b>GAIN</b>					
Range of Gain		1		1000	V/V
Gain Equation <sup>(1)</sup>			$G = 1 + 6\text{k}\Omega/R_G$		V/V
Gain Error, DC $G = 1$	$\pm 10\text{V}$ Output		0.005	0.05	%
$G = 100$			0.07	0.25	%
Equation			0.05		%
Gain Temp. Co. $G = 1$	$\pm 10\text{V}$ Output		10		ppm/ $^\circ\text{C}$
$G = 100$			25		ppm/ $^\circ\text{C}$
Equation			25		ppm/ $^\circ\text{C}$
Nonlinearity, DC $G = 1$	$\pm 10\text{V}$ Output		0.0003	0.01	% of FS <sup>(2)</sup>
$G = 100$			0.0006	0.01	% of FS
<b>OUTPUT</b>					
Voltage, $R_L = 600\Omega$	$T_A = T_{\text{MIN}}$ to $T_{\text{MAX}}$	$\pm 11.5$	$\pm 12$		V
$R_L = 600\Omega$	$V_S = \pm 25$ , $T_A = 25^\circ\text{C}$	$\pm 20$	$\pm 21$		V
Current	$T_A = T_{\text{MIN}}$ to $T_{\text{MAX}}$	$\pm 40$			mA
Short Circuit Current			$\pm 70$		mA
Capacitive Load Stability			10		nF
<b>INPUT OFFSET VOLTAGE</b>					
Initial Offset RTI <sup>(3)</sup>			(30 + 1200/G)		$\mu\text{V}$
(KU Grade)				(250 + 5000/G)	$\mu\text{V}$
vs Temp $G = 1$ to 1000	$T_A = T_{\text{MIN}}$ to $T_{\text{MAX}}$		1 + 20/G		$\mu\text{V}/^\circ\text{C}$
$G = 1000$	$T_A = T_{\text{MIN}}$ to $T_{\text{MAX}}$				$\mu\text{V}/^\circ\text{C}$
vs Supply	$\pm 9\text{V}$ to $\pm 25\text{V}$		0.2 + 8/G	4 + 60/G	$\mu\text{V}/\text{V}$
<b>INPUT BIAS CURRENT</b>					
Initial Bias Current	$T_A = T_{\text{MIN}}$ to $T_{\text{MAX}}$		2.5	12	$\mu\text{A}$
vs Temp			15		nA/ $^\circ\text{C}$
Initial Offset Current	$T_A = T_{\text{MIN}}$ to $T_{\text{MAX}}$		0.04	1	$\mu\text{A}$
vs Temp			0.5		nA/ $^\circ\text{C}$
<b>INPUT IMPEDANCE</b>					
Differential Mode			60    2		M $\Omega$    pF
Common-Mode			60    5		M $\Omega$    pF
<b>INPUT VOLTAGE RANGE</b>					
Common-Mode Range <sup>(4)</sup>		$\pm 11$	$\pm 12$		V
CMR					
$G = 1$	DC to 60Hz	72	86		dB
$G = 100$	DC to 60Hz	100	125		dB
<b>INPUT NOISE</b>					
Voltage <sup>(5)</sup>	$R_S = 0\Omega$				
10Hz			2		nV/ $\sqrt{\text{Hz}}$
100Hz			1.2		nV/ $\sqrt{\text{Hz}}$
1kHz			1		nV/ $\sqrt{\text{Hz}}$
Current, 1kHz			2		pA/ $\sqrt{\text{Hz}}$
<b>OUTPUT NOISE</b>					
Voltage	1kHz		65		nV/ $\sqrt{\text{Hz}}$
A Weighted, 20Hz-20kHz	20Hz-20kHz		-100		dBu
<b>DYNAMIC RESPONSE</b>					
-3dB Bandwidth: $G = 1$	Small Signal		6		MHz
$G = 100$	Small Signal		800		kHz
Full Power Bandwidth	$G = 1$				
$V_{\text{OUT}} = \pm 10\text{V}$ , $R_L = 600\Omega$			240		kHz
Slew Rate	$G = 1$ to 500		15		V/ $\mu\text{s}$
THD + Noise	$G = 100$ , $f = 1\text{kHz}$		0.0009		%
Settling Time 0.1%					
$G = 1$	$V_O = 20\text{V}$ Step		1.7		$\mu\text{s}$
$G = 100$			1.5		$\mu\text{s}$
Settling Time 0.01%					
$G = 1$	$V_O = 20\text{V}$ Step		2		$\mu\text{s}$
$G = 100$			3.5		$\mu\text{s}$
Overload Recovery <sup>(6)</sup>	50% Overdrive		1		$\mu\text{s}$

NOTES: (1) Gains other than 1 and 100 can be set by adding an external resistor,  $R_G$  between pins 2 and 15. Gain accuracy is a function of  $R_G$ . (2) FS = Full Scale. (3) Adjustable to zero. (4)  $V_O = 0\text{V}$ , see Typical Curves for  $V_{\text{CM}}$  vs  $V_O$ . (5)  $V_{\text{NOISE RTI}} = \sqrt{V_{\text{N INPUT}}^2 + (V_{\text{N OUTPUT}}/\text{Gain})^2 + 4\text{KTR}_G}$ . See Typical Curves. (6) Time required for output to return from saturation to linear operation following the removal of an input overdrive voltage.

# SPECIFICATIONS (CONT)

All specifications at  $T_A = +25^\circ\text{C}$ ,  $V_S = \pm 15\text{V}$  and  $R_L = 2\text{k}\Omega$ , unless otherwise noted.

PARAMETER	CONDITIONS	INA103KP, KU			UNITS
		MIN	TYP	MAX	
<b>POWER SUPPLY</b>					
Rated Voltage			$\pm 15$		V
Voltage Range		$\pm 9$		$\pm 25$	V
Quiescent Current			9	12.5	mA
<b>TEMPERATURE RANGE</b>					
Specification		0		+70	$^\circ\text{C}$
Operation		-40		+85	$^\circ\text{C}$
Storage		-40		+100	$^\circ\text{C}$
Thermal Resistance, $\theta_{JA}$			100		$^\circ\text{C/W}$

## PIN CONFIGURATION

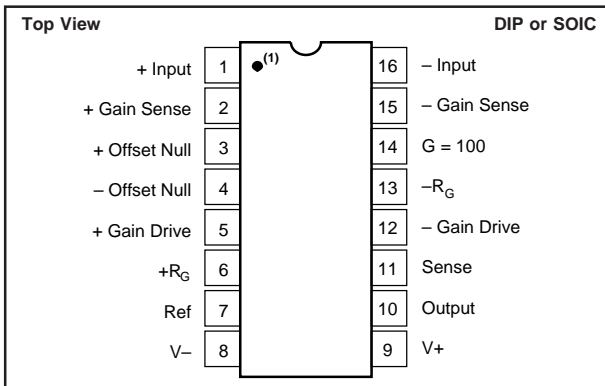

NOTE: (1) Pin 1 Marking—SOL-16 Package

## PACKAGE/ORDERING INFORMATION

PRODUCT	PACKAGE	PACKAGE DRAWING NUMBER <sup>(1)</sup>	TEMPERATURE RANGE
INA103KP	Plastic DIP	180	0 $^\circ\text{C}$ to +70 $^\circ\text{C}$
INA103KU	SOL-16	211	0 $^\circ\text{C}$ to +70 $^\circ\text{C}$

NOTE: (1) For detailed drawing and dimension table, please see end of data sheet, or Appendix C of Burr-Brown IC Data Book.

## ELECTROSTATIC DISCHARGE SENSITIVITY

Any integrated circuit can be damaged by ESD. Burr-Brown recommends that all integrated circuits be handled with appropriate precautions. Failure to observe proper handling and installation procedures can cause damage.

ESD damage can range from subtle performance degradation to complete device failure. Precision integrated circuits may be more susceptible to damage because very small parametric changes could cause the device not to meet published specifications.

## ABSOLUTE MAXIMUM RATINGS<sup>(1)</sup>

Power Supply Voltage	$\pm 25\text{V}$
Input Voltage Range, Continuous	$\pm V_S$
Operating Temperature Range:	-40 $^\circ\text{C}$ to +85 $^\circ\text{C}$
Storage Temperature Range:	-40 $^\circ\text{C}$ to +85 $^\circ\text{C}$
Junction Temperature:	
P, U Package	+125 $^\circ\text{C}$
Lead Temperature (soldering, 10s)	+300 $^\circ\text{C}$
Output Short Circuit to Common	Continuous

NOTE: (1) Stresses above these ratings may cause permanent damage.

The information provided herein is believed to be reliable; however, BURR-BROWN assumes no responsibility for inaccuracies or omissions. BURR-BROWN assumes no responsibility for the use of this information, and all use of such information shall be entirely at the user's own risk. Prices and specifications are subject to change without notice. No patent rights or licenses to any of the circuits described herein are implied or granted to any third party. BURR-BROWN does not authorize or warrant any BURR-BROWN product for use in life support devices and/or systems.

# TYPICAL PERFORMANCE CURVES

At  $T_A = +25^\circ\text{C}$ ,  $V_S = \pm 15\text{V}$ , unless otherwise noted.

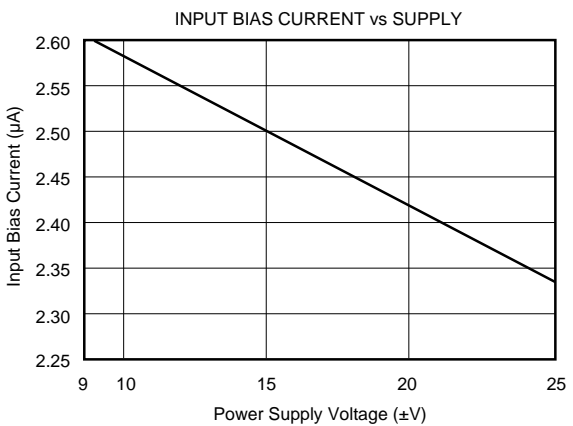
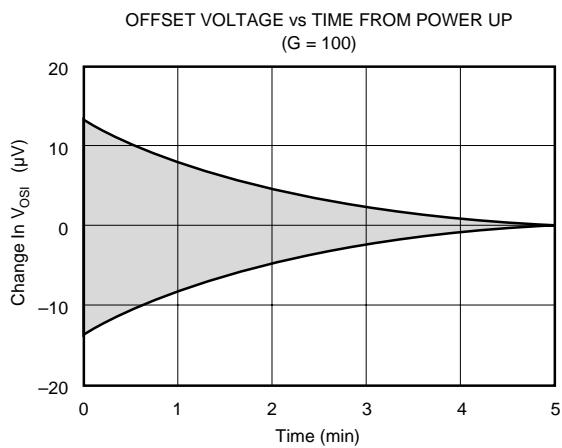
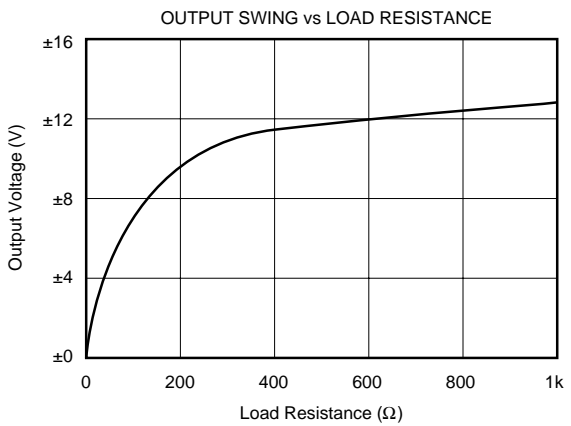
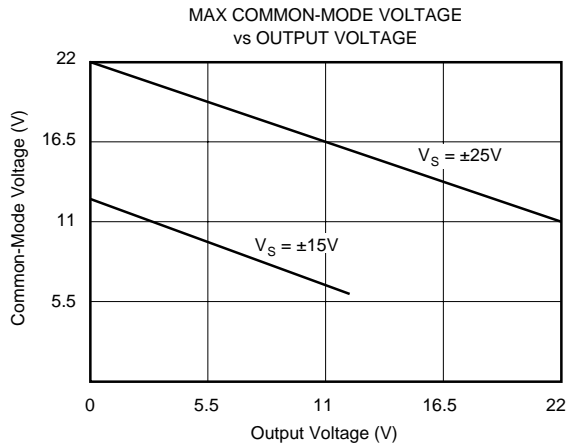
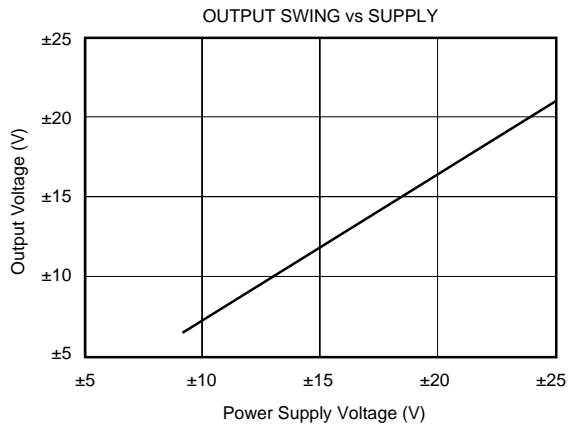
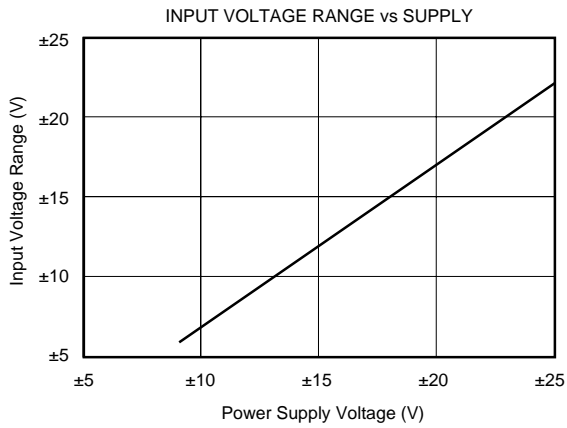

# TYPICAL PERFORMANCE CURVES (CONT)

At  $T_A = +25^\circ\text{C}$ ,  $V_S = \pm 15\text{V}$ , unless otherwise noted.

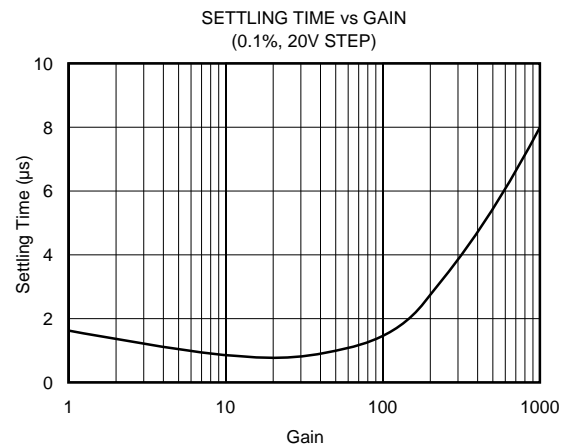
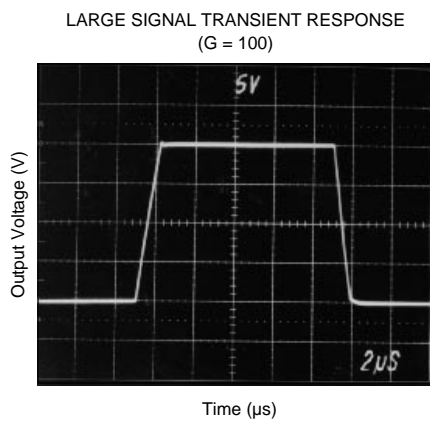
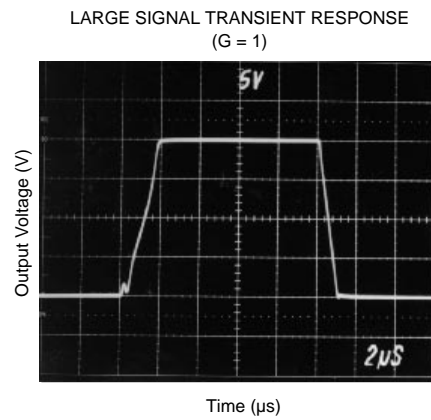
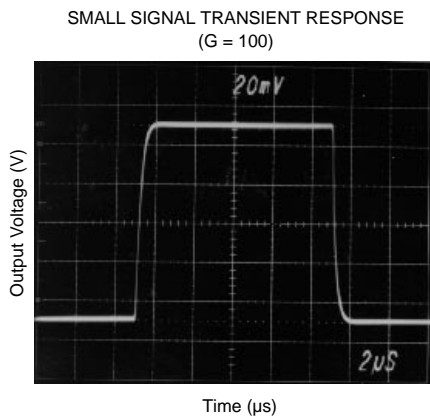
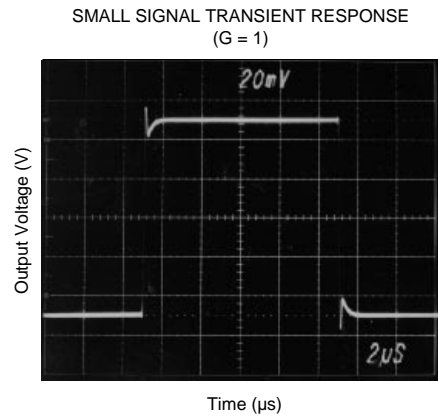
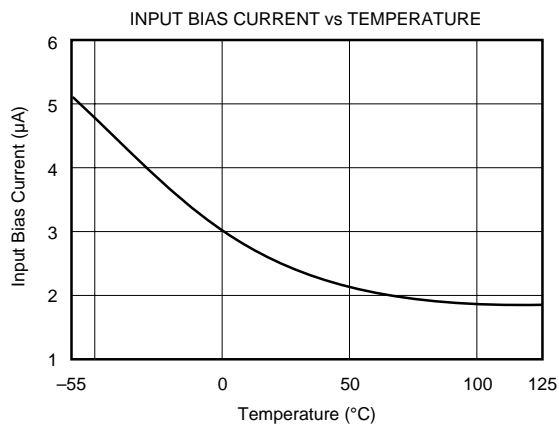

# TYPICAL PERFORMANCE CURVES (CONT)

At  $T_A = +25^\circ\text{C}$ ,  $V_S = \pm 15\text{V}$ , unless otherwise noted.

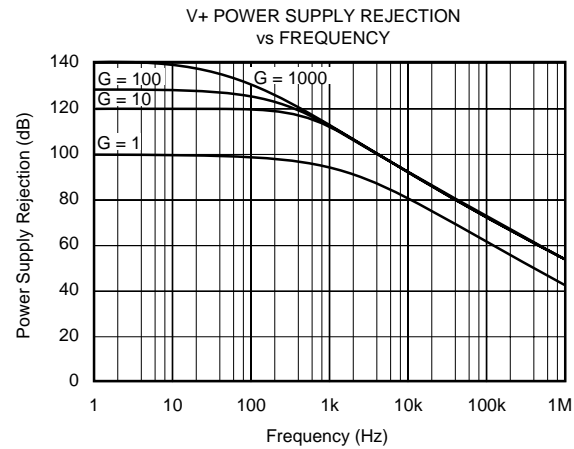
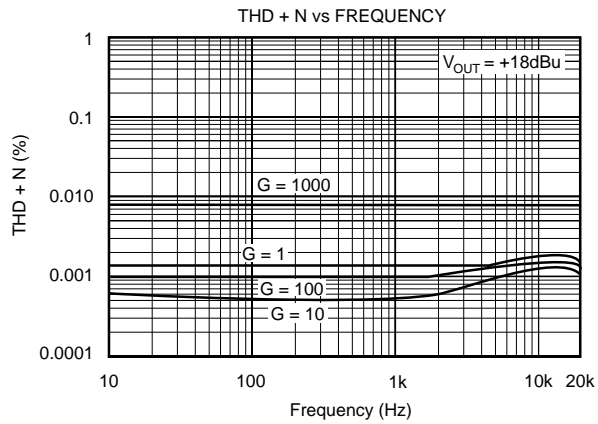
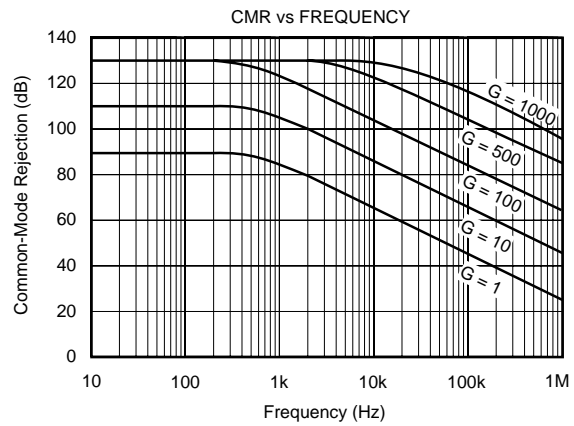
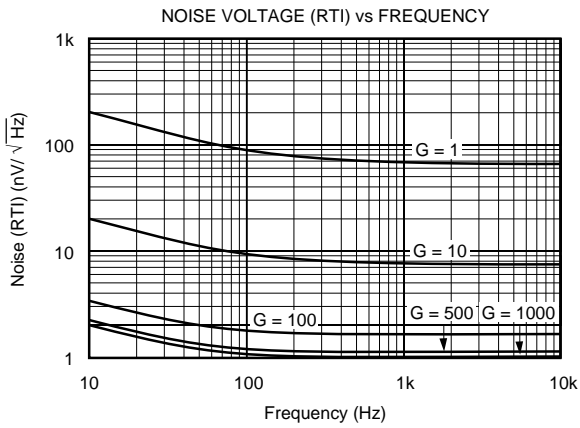
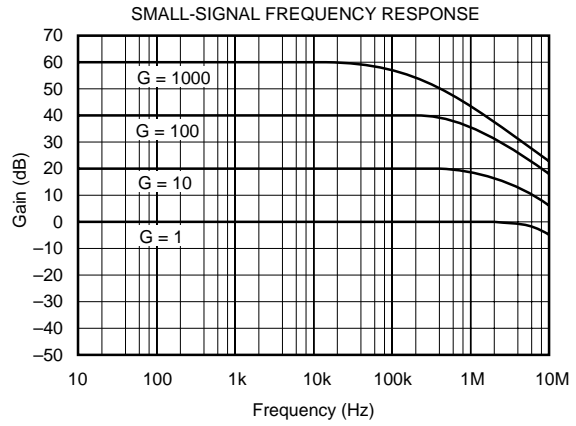
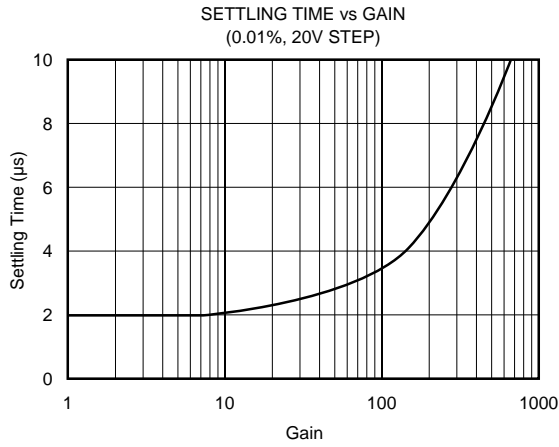

# TYPICAL PERFORMANCE CURVES (CONT)

At  $T_A = +25^\circ\text{C}$ ,  $V_S = \pm 15\text{V}$ , unless otherwise noted.

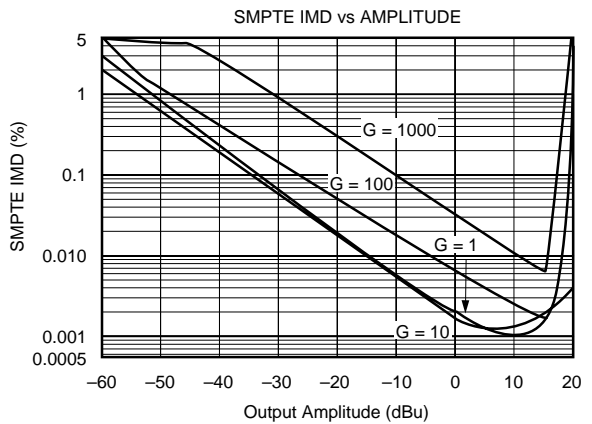
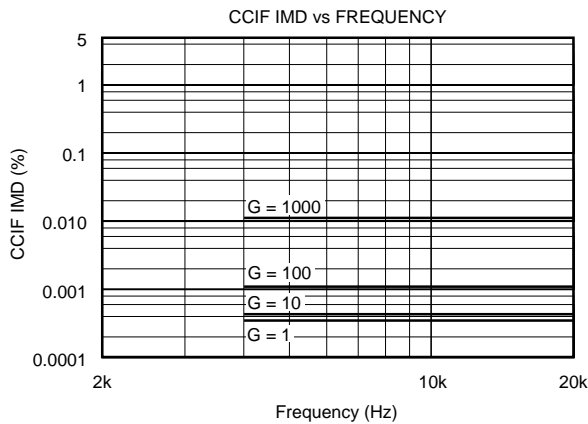
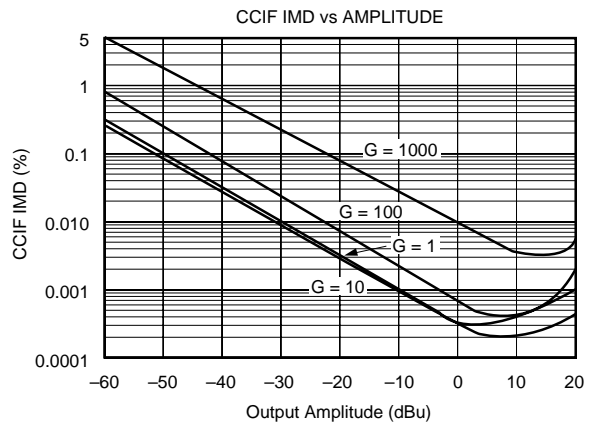
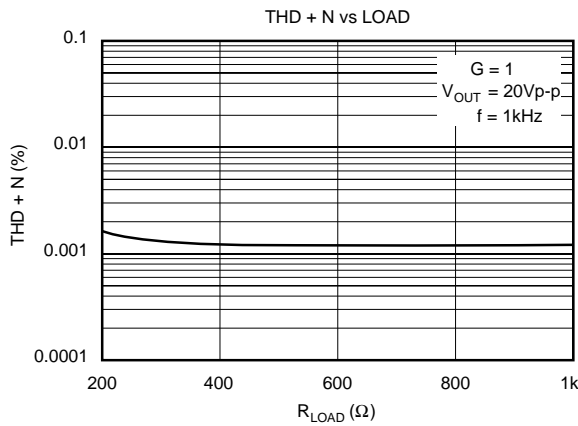
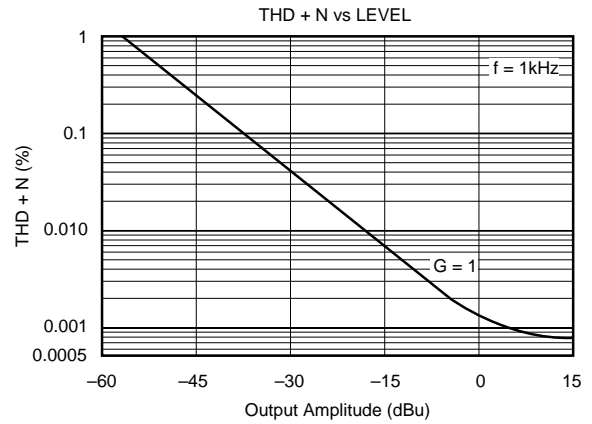
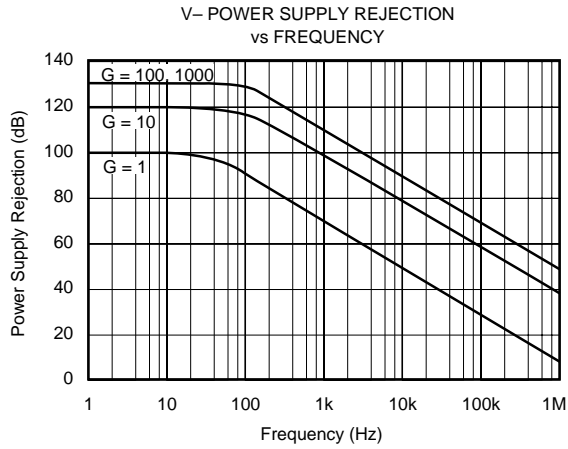

# TYPICAL PERFORMANCE CURVES (CONT)

At  $T_A = +25^\circ\text{C}$ ,  $V_S = \pm 15\text{V}$  unless, otherwise noted.

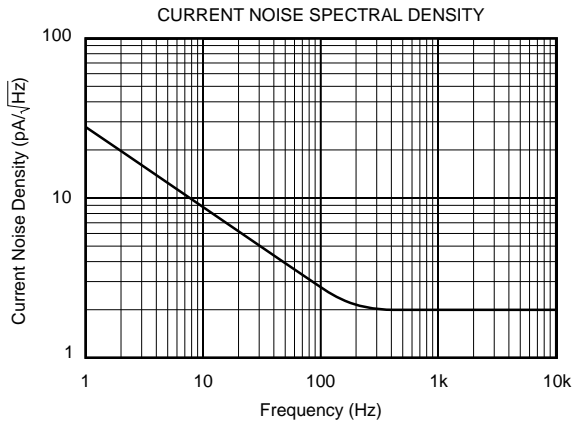
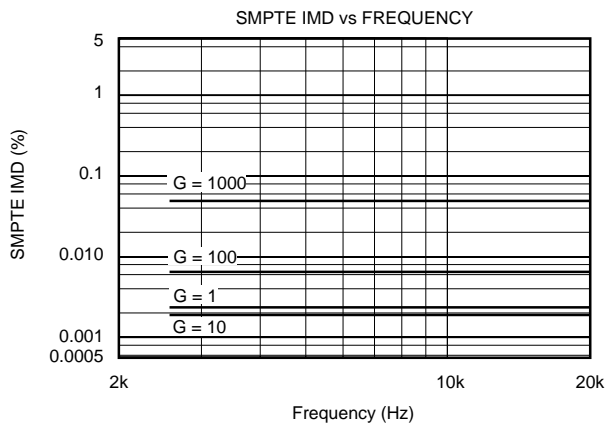

## APPLICATIONS INFORMATION

Figure 1 shows the basic connections required for operation. Power supplies should be bypassed with  $1\mu\text{F}$  tantalum capacitors near the device pins. The output Sense (pin 11) and output Reference (pin 7) should be low impedance connections. Resistance of a few ohms in series with these connections will degrade the common-mode rejection of the amplifier.

To avoid oscillations, make short, direct connection to the gain set resistor and gain sense connections. Avoid running output signals near these sensitive input nodes.

### INPUT CONSIDERATIONS

Certain source impedances can cause the INA103 to oscillate. This depends on circuit layout and source or cable characteristics connected to the input. An input network consisting of a small inductor and resistor (Figure 2) can greatly reduce the tendency to oscillate. This is especially

useful if various input sources are connected to the INA103. Although not shown in other figures, this network can be used, if needed, with all applications shown.

### GAIN SELECTION

Gains of 1 or  $100\text{V/V}$  can be set without external resistors. For  $G = 1\text{V/V}$  (unity gain) leave pin 14 open (no connection)—see Figure 4. For  $G = 100\text{V/V}$ , connect pin 14 to pin 6—see Figure 5.

Gain can also be accurately set with a single external resistor as shown in Figure 1. The two internal feedback resistors are laser-trimmed to  $3\text{k}\Omega$  within approximately  $\pm 0.1\%$ . The temperature coefficient of these resistors is approximately  $50\text{ppm}/^\circ\text{C}$ . Gain using an external  $R_G$  resistor is—

$$G = 1 + \frac{6\text{k}\Omega}{R_G}$$



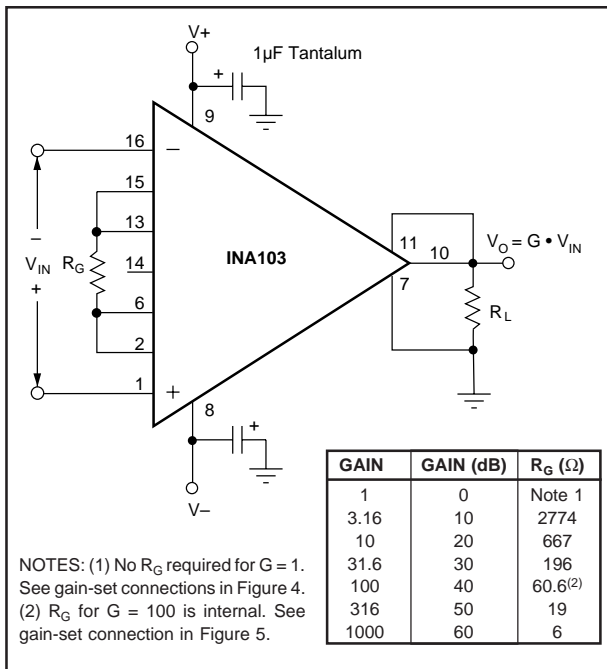

FIGURE 1. Basic Circuit Configuration.

Accuracy and TCR of the external R<sub>G</sub> will also contribute to gain error and temperature drift. These effects can be directly inferred from the gain equation.

Connections available on A<sub>1</sub> and A<sub>2</sub> allow external resistors to be substituted for the internal 3kΩ feedback resistors. A precision resistor network can be used for very accurate and stable gains. To preserve the low noise of the INA103, the value of external feedback resistors should be kept low. Increasing the feedback resistors to 20kΩ would increase noise of the INA103 to approximately 1.5nV/√Hz. Due to the current-feedback input circuitry, bandwidth would also be reduced.

### NOISE PERFORMANCE

The INA103 provides very low noise with low source impedance. Its 1nV/√Hz voltage noise delivers near theoretical noise performance with a source impedance of 200Ω. Relatively high input stage current is used to achieve this low noise. This results in relatively high input bias current and input current noise. As a result, the INA103 may not provide best noise performance with source impedances greater than 10kΩ. For source impedance greater than 10kΩ, consider the INA114 (excellent for precise DC applications), or the INA111 FET-input IA for high speed applications.

### OFFSET ADJUSTMENT

Offset voltage of the INA103 has two components: input stage offset voltage is produced by A<sub>1</sub> and A<sub>2</sub>; and, output stage offset is produced by A<sub>3</sub>. Both input and output stage offset are laser trimmed and may not need adjustment in many applications.

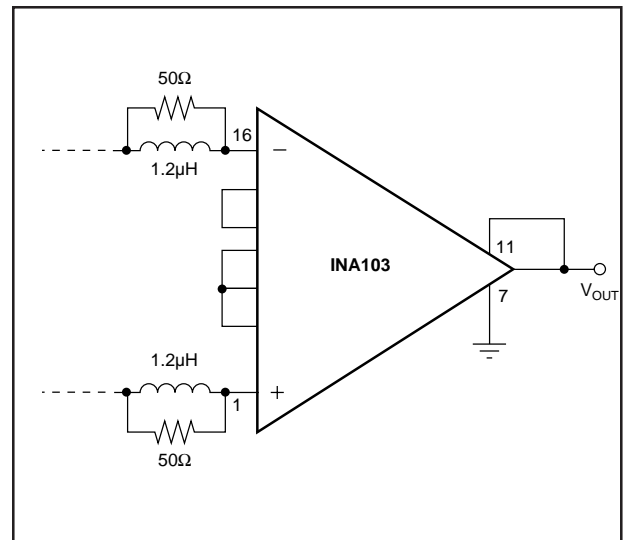

FIGURE 2. Input Stabilization Network.

Offset voltage can be trimmed with the optional circuit shown in Figure 3. This offset trim circuit primarily adjusts the output stage offset, but also has a small effect on input stage offset. For a 1mV adjustment of the output voltage, the input stage offset is adjusted approximately 1µV. Use this adjustment to null the INA103's offset voltage with zero differential input voltage. Do not use this adjustment to null offset produced by a sensor, or offset produced by subsequent stages, since this will increase temperature drift.

To offset the output voltage without affecting drift, use the circuit shown in Figure 4. The voltage applied to pin 7 is summed at the output. The op amp connected as a buffer provides a low impedance at pin 7 to assure good common-mode rejection.

Figure 5 shows a method to trim offset voltage in AC-coupled applications. A nearly constant and equal input bias current of approximately 2.5µA flows into both input terminals. A variable input trim voltage is created by adjusting the balance of the two input bias return resistances through which the input bias currents must flow.

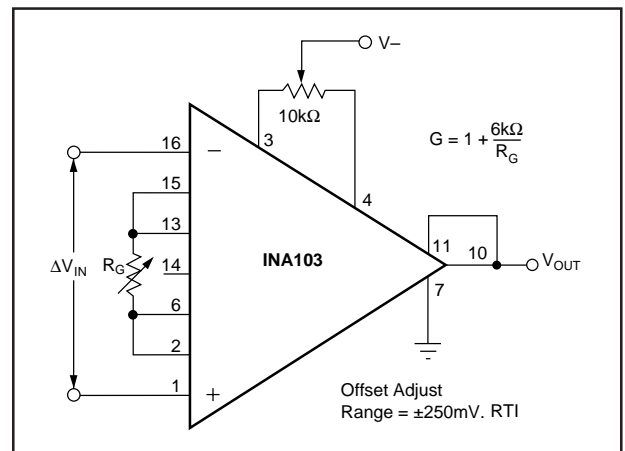

FIGURE 3. Offset Adjustment Circuit.

Figure 6 shows an active control loop that adjusts the output offset voltage to zero. A<sub>2</sub>, R, and C form an integrator that produces an offsetting voltage applied to one input of the INA103. This produces a -6dB/octave low frequency roll-off like the capacitor input coupling in Figure 5.

### COMMON-MODE INPUT RANGE

For proper operation, the combined differential input signal and common-mode input voltage must not cause the input amplifiers to exceed their output swing limits. The linear input range is shown in the typical performance curve "Maximum Common-Mode Voltage vs Output Voltage." For a given total gain, the input common-mode range can be increased by reducing the input stage gain and increasing the output stage gain with the circuit shown in Figure 7.

### OUTPUT SENSE

An output sense terminal allows greater gain accuracy in driving the load. By connecting the sense connection at the load, I•R voltage loss to the load is included inside the feedback loop. Current drive can be increased by connecting a current booster inside the feedback loop as shown in Figure 11.

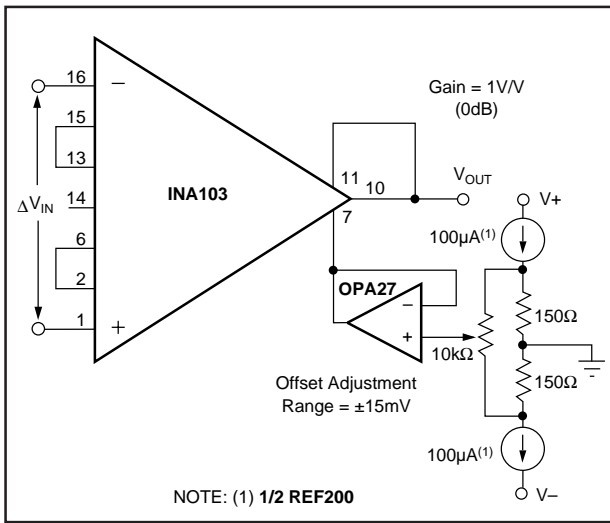

FIGURE 4. Output Offsetting.

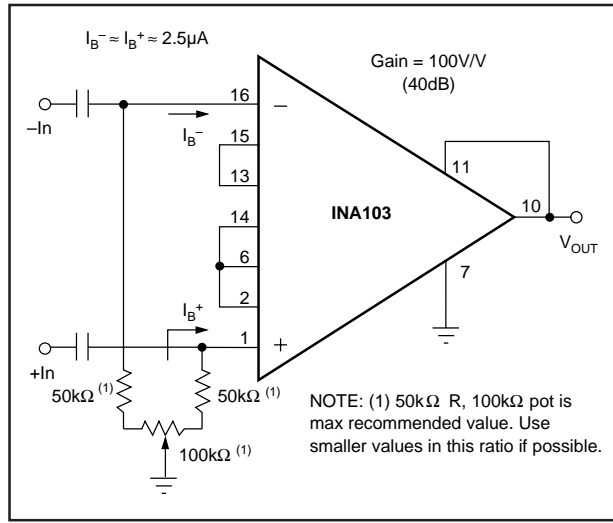

FIGURE 5. Input Offset Adjustment for AC-Coupled Inputs.

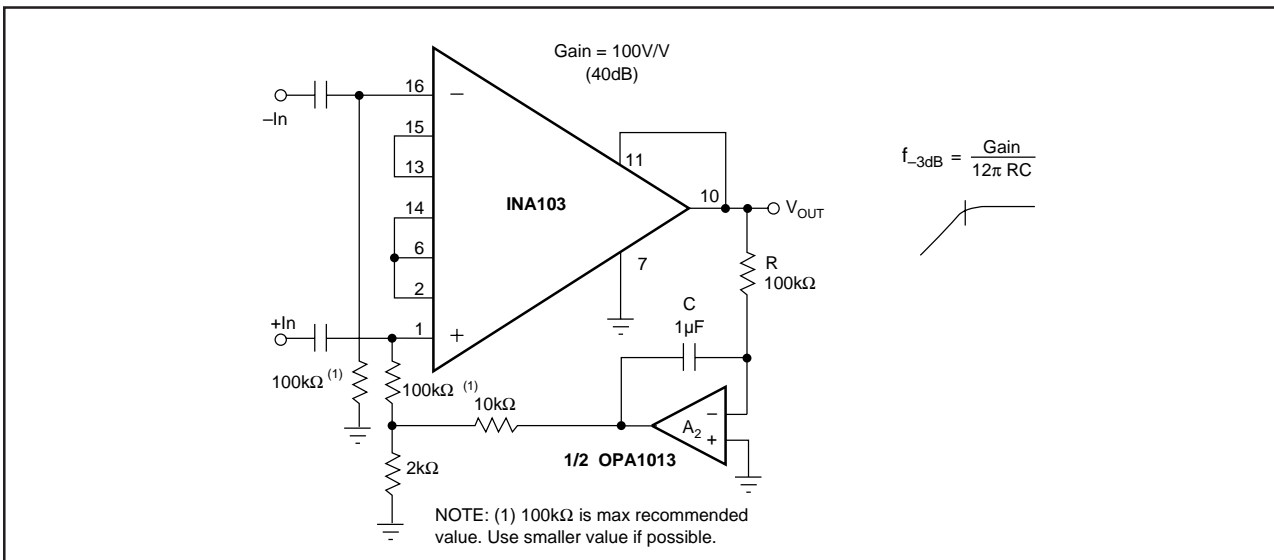

FIGURE 6. Automatic DC Restoration.

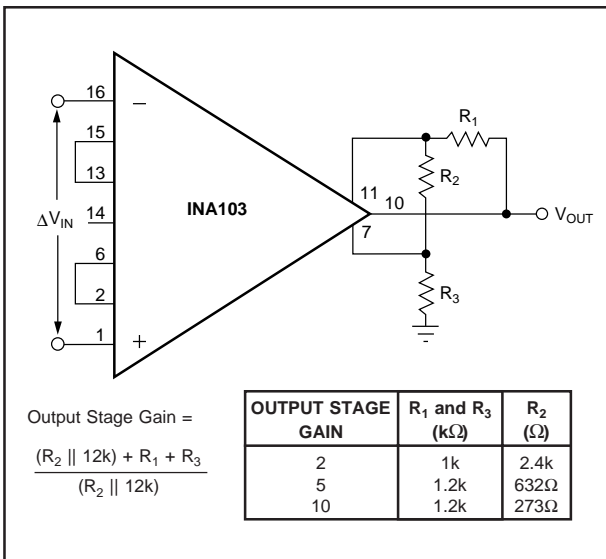

FIGURE 7. Gain Adjustment of Output Stage.

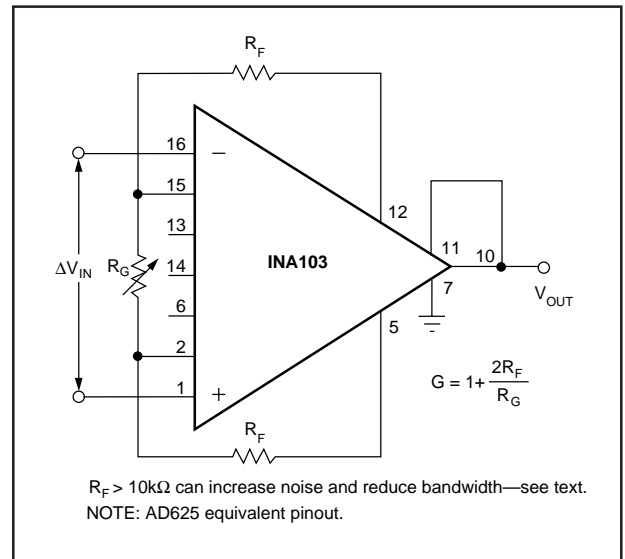

FIGURE 8. Use of External Resistors for Gain Set.

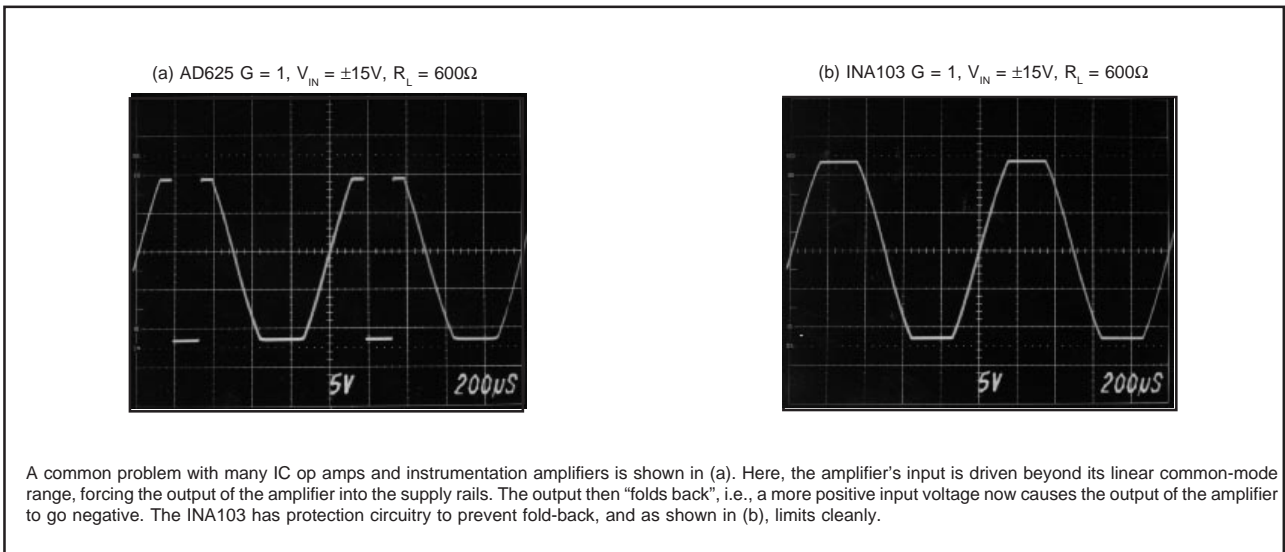

FIGURE 9. INA103 Overload Condition Performance.

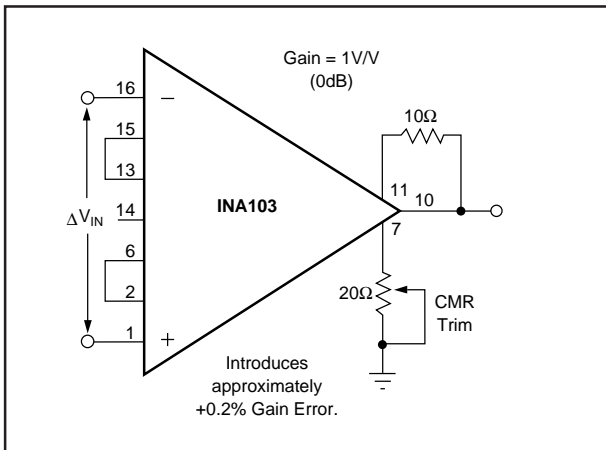

FIGURE 10. Optional Circuit for Externally Trimming CMR.

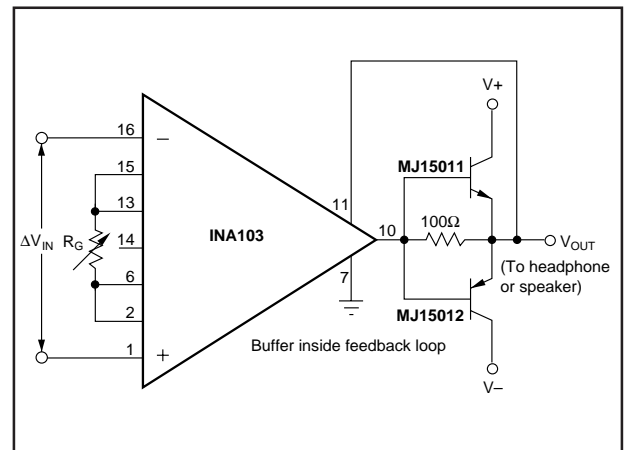

FIGURE 11. Increasing Output Circuit Drive.

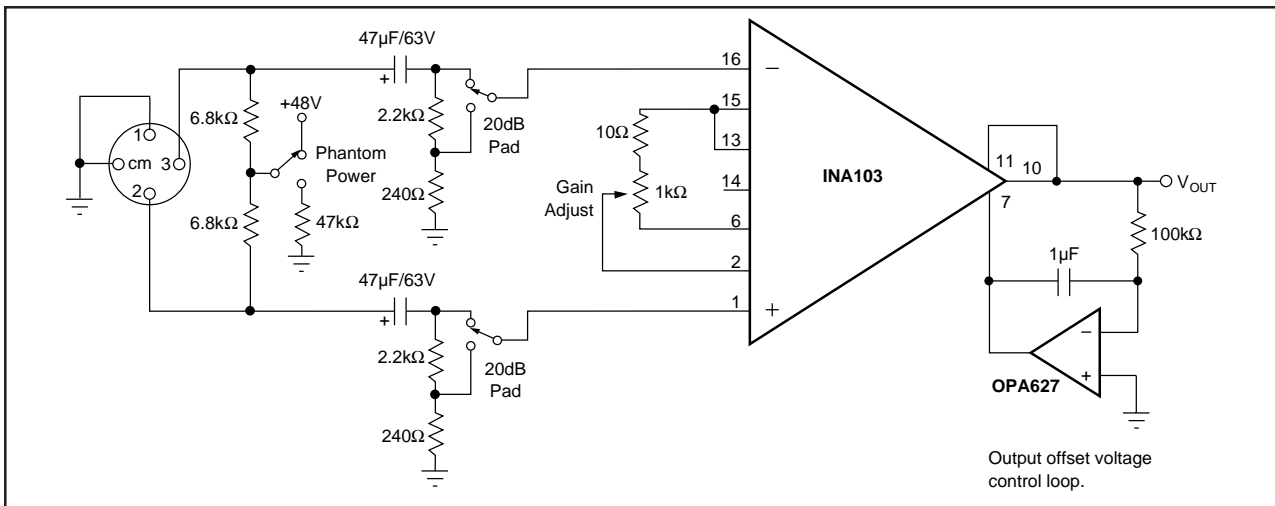

FIGURE 12. Microphone Preamplifier with Provision for Phantom Power Microphones.

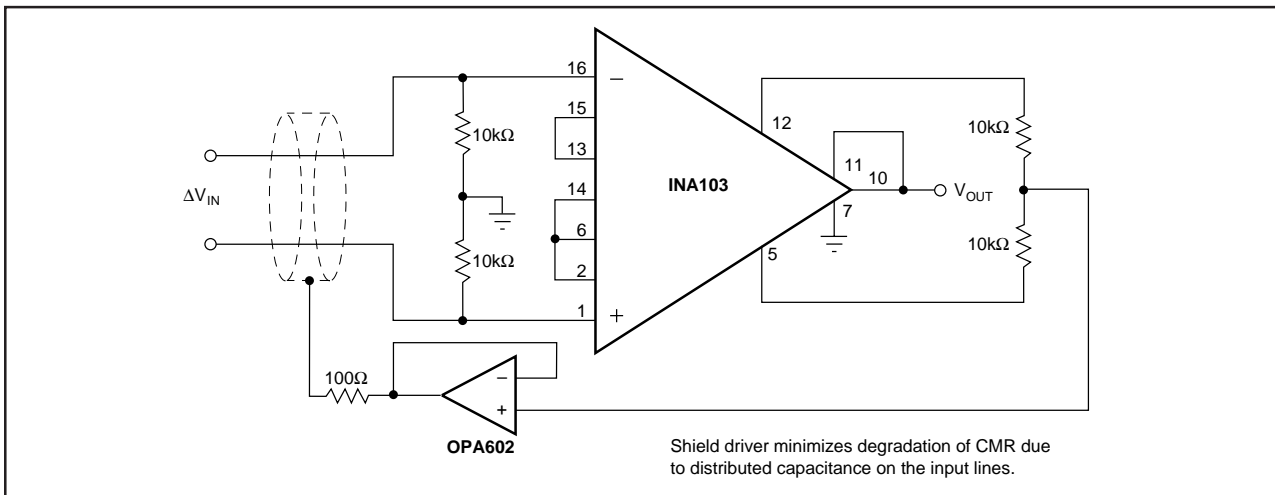

FIGURE 13. Instrumentation Amplifier with Shield Driver.

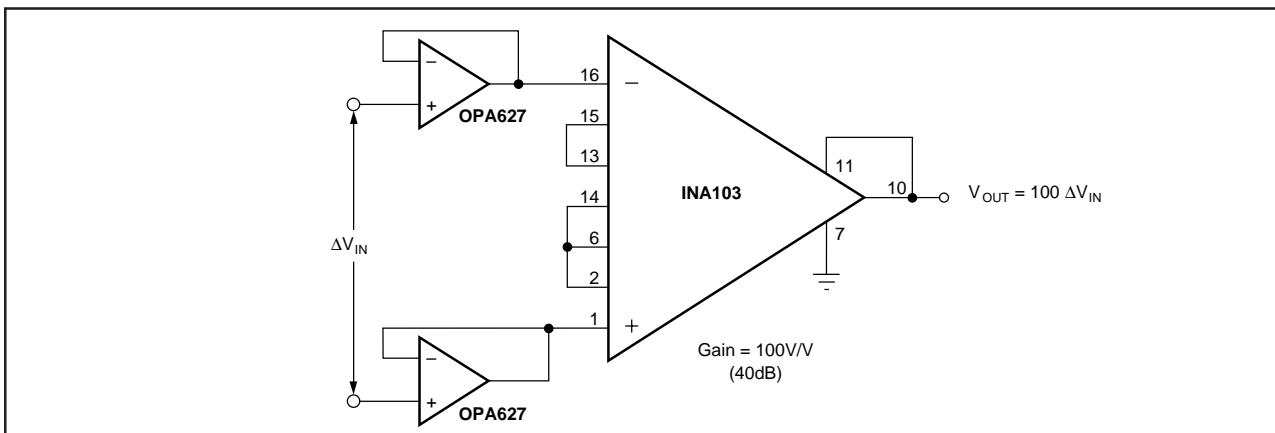

FIGURE 14. Gain-of-100 INA103 with FET Buffers.

## **IMPORTANT NOTICE**

Texas Instruments and its subsidiaries (TI) reserve the right to make changes to their products or to discontinue any product or service without notice, and advise customers to obtain the latest version of relevant information to verify, before placing orders, that information being relied on is current and complete. All products are sold subject to the terms and conditions of sale supplied at the time of order acknowledgment, including those pertaining to warranty, patent infringement, and limitation of liability.

TI warrants performance of its semiconductor products to the specifications applicable at the time of sale in accordance with TI's standard warranty. Testing and other quality control techniques are utilized to the extent TI deems necessary to support this warranty. Specific testing of all parameters of each device is not necessarily performed, except those mandated by government requirements.

Customers are responsible for their applications using TI components.

In order to minimize risks associated with the customer's applications, adequate design and operating safeguards must be provided by the customer to minimize inherent or procedural hazards.

TI assumes no liability for applications assistance or customer product design. TI does not warrant or represent that any license, either express or implied, is granted under any patent right, copyright, mask work right, or other intellectual property right of TI covering or relating to any combination, machine, or process in which such semiconductor products or services might be or are used. TI's publication of information regarding any third party's products or services does not constitute TI's approval, warranty or endorsement thereof.