



# MINIATURE ALUMINUM ELECTROLYTIC CAPACITORS

CAT. No. E1001F

INDEX		
<b>PRODUCT SEARCH</b>	SERIES TABLE	➔
	GROUP CHART	➔
<b>PRODUCTION GUIDE</b>	PRECAUTIONS AND GUIDELINES (Aluminum Electrolytic Capacitor)	➔
	PART NUMBERING SYSTEM	➔
	ENVIRONMENTAL CONSIDERATION	➔
	PACKAGING	➔
	TAPING SPECIFICATIONS	➔
	STANDARDIZATION	➔
	WORLD-WIDE MANUFACTURING LOCATIONS	➔
<b>PRODUCT SPECIFICATIONS</b>	RADIAL LEAD TYPE	➔
<b>RELIABILITY DATA</b>		➔
<b>APPENDIX (GLOBAL CODE)</b>		➔

Series	Features	Endurance (+R=With ripple)	Standard type	Low impedance	Solvent-proof	Terminal type	Rated voltage range (V <sub>dc</sub> )	Capacitance range (μF)		
Conductive Polymer Electrolyte Type	PXE <small>(NEW)</small>	Vertical type, super low ESR, high ripple current	105°C 2,000 hours		●	●	SMD	2.5 to 16	33 to 1,200	
	PXC	Vertical type, super low ESR	105°C 1,000 hours		●	●	SMD	2.5 to 16	27 to 470	
	PXA <small>(Upgrade!)</small>	Vertical type, super low ESR	105°C 2,000 hours		●	●	SMD	2.5 to 25	3.3 to 1,500	
	PXH	125°C Vertical type	125°C 1,000 hours		●	●	SMD	2.5 to 20	22 to 1,000	
	PSC <small>(NEW)</small>	Radial lead type, super low ESR, high ripple current	105°C 2,000 hours		●	●	Radial	2.5 to 16	330 to 2,700	
	PSA	Super low ESR, high ripple current	105°C 2,000 hours		●	●	Radial	2.5 to 16	100 to 1,000	
	PS	Super low ESR, high ripple current	105°C 2,000 hours		●	●	Radial	2.5 to 25	68 to 1,500	
Surface Mount	Vertical Type	MVS	4.5mm height	85°C 2,000 hours	●	●	SMD	4 to 50	0.1 to 220	
		MVA	5.5 to 22.0mm max. height, downsized	85°C 2,000 hours		▲	SMD	4 to 450	0.1 to 10,000	
		MV	5.5 to 10.5mm max. height	85°C 1,000 to 2,000 hours	●	●	SMD	4 to 63	0.1 to 1,000	
		MVE	5.5 to 22.0mm max. height, downsized	105°C 1,000 to 2,000 hours		▲	SMD	6.3 to 450	0.47 to 6,800	
		MVK	5.5 to 10.5mm max. height	105°C 1,000 to 2,000 hours	●	●	SMD	6.3 to 50	0.1 to 1,000	
		MKA	5.5 to 10.5mm max. height	105°C 1,000 to 2,000 hours		●	SMD	6.3 to 50	0.1 to 1,000	
		MZA <small>(Upgrade!)</small>	6.1 to 10.5mm max. height, very low impedance	105°C 2,000 hours		●	●	SMD	6.3 to 80	3.3 to 1,500
		MVY	5.5 to 22.0mm max. height	105°C 1,000 to 5,000 hours		●	▲	SMD	6.3 to 100	1.0 to 8,200
		MZD <small>(NEW)</small>	105°C 5,000 hours, low impedance, long life <small>(Ask Engineering Bulletin No758 in detail)</small>	105°C 5,000 hours		●	●	SMD	6.3 to 50	10 to 470
		MLA <small>(NEW)</small>	Low impedance, long life	105°C 3,000 hours		●	●	SMD	6.3 to 50	10 to 1,000
		MVJ	6.0mm max. height <small>(Ask Engineering Bulletin No653 in detail)</small>	105°C 2,000 hours			●	SMD	6.3 to 50	0.1 to 100
		MLD <small>(NEW)</small>	105°C 5,000 hours, long life <small>(Ask Engineering Bulletin No759 in detail)</small>	105°C 5,000 hours			●	SMD	6.3 to 50	0.1 to 1,000
		MVL	6.0 to 10.5mm max. height	105°C 3,000 to 5,000 hours			●	SMD	6.3 to 50	0.1 to 1,000
		MVH <small>(Upgrade!)</small>	6.0 to 22.0mm max. height	125°C 1,000 to 5,000 hours			▲	SMD	10 to 450	3.3 to 4,700
		MV-BP	5.5mm max. height, bi-polar	85°C 2,000 hours			●	SMD	4 to 50	0.1 to 47
MVK-BP	6.0mm max. height, bi-polar	105°C 1,000 hours			●	SMD	6.3 to 50	0.1 to 47		
Miniature	Low Profile	SRM	5mm height, downsized	85°C 1,000 hours		●	Radial	4 to 50	0.1 to 330	
		SRE	5mm height	85°C 1,000 hours	●		Radial	4 to 50	0.1 to 100	
		KRE	5mm height	105°C 1,000 hours	●	●	Radial	6.3 to 50	0.1 to 100	
		SRA	7mm height	85°C 1,000 hours	●		Radial	4 to 63	0.1 to 470	
		KMA	7mm height	105°C 1,000 hours	●	●	Radial	4 to 63	0.1 to 220	
		SRG	φ4×7 to φ18×25mm, low profile	85°C 1,000 to 2,000 hours			●	Radial	4 to 50	0.1 to 10,000
		KRG	φ4×7 to φ18×25mm, low profile	105°C 1,000 hours			●	Radial	6.3 to 50	0.1 to 10,000
	General Purpose	SMQ	Downsized	85°C 2,000 hours	●		Radial	6.3 to 450	0.1 to 47,000	
		KMQ	Downsized	105°C 1,000 to 2,000 hours +R	●	▲	Radial	6.3 to 450	0.1 to 47,000	
		SMG	General, downsized	85°C 2,000 hours	●	▲	Radial	6.3 to 450	0.1 to 39,000	
		KMG	General, downsized	105°C 1,000 to 2,000 hours +R	●	▲	Radial	6.3 to 450	0.1 to 22,000	
		SME	General <small>(Ask Engineering Bulletin No511 in detail)</small>	85°C 2,000 hours			▲	Radial	6.3 to 450	0.1 to 15,000
		KME	General <small>(Ask Engineering Bulletin No512 in detail)</small>	105°C 1,000 hours +R			▲	Radial	6.3 to 400	0.1 to 15,000
		SME-BP	Bi-polar, general	85°C 2,000 hours	●	●	Radial	6.3 to 100	0.47 to 6,800	
	KME-BP	Bi-polar, general	105°C 1,000 hours	●	●	Radial	6.3 to 100	0.47 to 6,800		
High Frequency Use	KZM <small>(NEW)</small>	Lowest impedance, long life	105°C 6,000 to 10,000 hours +R	●		Radial	6.3 to 35	27 to 10,000		
	KZH	Lowest impedance, long life	105°C 5,000 to 6,000 hours +R	●		Radial	6.3 to 35	47 to 8,200		
	KZE	Lowest impedance, long life	105°C 1,000 to 5,000 hours +R	●		Radial	6.3 to 100	6.8 to 6,800		
	KY <small>(Upgrade!)</small>	Low impedance, long life	105°C 4,000 to 10,000 hours +R		●	Radial	6.3 to 100	0.47 to 18,000		
	LXZ	Low impedance, downsized	105°C 2,000 to 8,000 hours +R	●	●	Radial	6.3 to 63	12 to 18,000		
	LXY	Low impedance, high reliability	105°C 2,000 to 8,000 hours +R	●	●	Radial	10 to 63	10 to 8,200		
	LXV	Low impedance	105°C 2,000 to 5,000 hours +R		●	●	Radial	6.3 to 100	5.6 to 15,000	
KMF	Low impedance, high CV, general <small>(Ask Engineering Bulletin No630 in detail)</small>	105°C 2,000 hours +R		●		Radial	160 to 450	2.2 to 220		

■ : Promotional products

▲ : Some of range are solvent-proof.

Series		Features	Endurance (+R=With ripple)	Standard type	Low impedance	Solvent-proof	Terminal type	Rated voltage range (V <sub>dc</sub> )	Capacitance range (μF)	
Miniature	High Reliability	<b>KXJ</b> <small>(NEW)</small>	Downsized, long life, for input filtering	105°C 10,000 to 12,000 hours +R	●		Radial	160 to 400	10 to 680	
		<b>KXG</b>	Downsized, long life, for input filtering	105°C 8,000 to 10,000 hours +R	●		Radial	160 to 450	6.8 to 330	
		<b>KMX</b>	Long life, for input filtering <small>(Ask Engineering Bulletin No 646 in detail)</small>	105°C 8,000 to 10,000 hours +R	●		Radial	160 to 450	3.3 to 680	
		<b>SMH</b>	φ20×20 to φ22×50mm	85°C 2,000 hours +R	●		Radial	160 to 450	33 to 470	
		<b>KMH</b>	φ20×20 to φ22×50mm	105°C 2,000 hours +R	●		Radial	160 to 450	33 to 470	
		<b>PAG</b>	Low profile, for input filtering	105°C 2,000 hours +R			Radial	200 to 450	18 to 560	
		<b>KLJ</b> <small>(NEW)</small>	Downsized, no sparks with DC overvoltage	105°C 2,000 hours +R			Radial	200 & 400	4.7 to 330	
		<b>KLG</b>	No sparks with DC overvoltage	105°C 2,000 hours +R			Radial	200 & 400	22 to 330	
		<b>FL</b>	Long life	105°C 3,000 hours +R		●	Radial	6.3 to 50	0.47 to 270	
		<b>GPA</b> <small>(NEW)</small>	125°C, downsized, low impedance	125°C 3,000 to 5,000 hours +R	●	●	Radial	25 to 63	330 to 6,800	
		<b>GXE</b>	125°C, downsize, low impedance	125°C 2,000 to 5,000 hours +R	●	▲	Radial	10 to 450	4.7 to 4,700	
		<b>GXL</b>	125°C Long life	125°C 5,000/10,000 hours +R		●	Radial	10 to 50	100 to 4,700	
		<b>GHA</b> <small>(NEW)</small>	150°C (Ask Engineering Bulletin No715 in detail)	150°C 1,000 hours		●	Radial	10 to 100	10 to 10,000	
	Special Application	<b>LBG</b> <small>(Upgrade!)</small>	For airbag	105°C 5,000 hours +R	●	●	Radial	25 to 35	1,000 to 11,000	
		<b>KZV</b> <small>(NEW)</small>	For PC motherboard <small>(Ask Engineering Bulletin No756 in detail)</small>	105°C 2,000 hours +R	●		Radial	4	820 to 2,700	
		<b>KZJ</b> <small>(NEW)</small>	For PC motherboard	105°C 2,000 hours +R	●		Radial	6.3 to 16	470 to 3,300	
		<b>KZG</b>	For PC motherboard	105°C 2,000 hours +R	●		Radial	6.3 to 16	470 to 3,300	
		<b>LLA</b>	Low DC leakage, general	85°C 1,000 hours		●	Radial	6.3 to 50	0.1 to 15,000	
		<b>PH</b>	For photo flash	55°C 5,000 times charging			Radial	300 & 330	—	
	Large Sized	General Purpose	<b>KMR</b> <small>(NEW)</small>	105°C, Snap-in terminal, super downsized	105°C 2,000 hours +R	●		Pin	160 to 450	100 to 3,900
			<b>SMQ</b>	Snap-in terminal, more downsized	85°C 2,000 hours +R	●		Pin	160 to 450	82 to 3,900
			<b>KMQ</b> <small>(Upgrade!)</small>	Snap-in terminal, more downsized	105°C 2,000 hours +R	●		Pin	160 to 450	68 to 3,300
<b>SMM</b>			Snap-in terminal, downsized	85°C 3,000 hours +R	●		Pin	35, 50, 160 to 450	47 to 33,000	
<b>KMM</b>			Snap-in terminal, downsized	105°C 2,000 to 3,000 hours +R	●		Pin	160 to 450	39 to 3,300	
<b>SMH</b>			Snap-in terminal, general <small>(Refer Engineering Bulletin No585 for 160 to 450V)</small>	85°C 2,000 hours +R	●		Pin	6.3 to 100	820 to 100,000	
<b>KMH</b>			Snap-in terminal, general <small>(Refer Engineering Bulletin No584 for 160 to 450V)</small>	105°C 2,000 hours +R	●		Pin	6.3 to 100	560 to 82,000	
Low Profile		<b>SLM</b>	15mm height	85°C 2,000 hours +R			Pin	160 to 400	47 to 560	
		<b>KLM</b>	15mm height	105°C 2,000 hours +R			Pin	160 to 400	39 to 390	
High Reliability		<b>LXM</b>	Long life	105°C 7,000 hours +R			Pin	160 to 450	47 to 2,200	
		<b>LXQ</b>	Long life, downsized	105°C 5,000 hours +R			Pin	160 to 450	82 to 2,700	
		<b>LXG</b>	Long life	105°C 5,000 hours +R			Pin	10 to 100	390 to 47,000	
		<b>CHA</b>	No sparks with DC overvoltage, downsized	105°C 2,000 hours +R			Pin	200 & 400	56 to 1,200	
		<b>LXH</b>	No sparks with DC overvoltage	105°C 3,000/5,000 hours +R			Pin	200 & 400	68 to 1,500	
		<b>RWE-LR</b>	For air-conditioning <small>(Ask Engineering Bulletin No768 in detail)</small>	85°C 3,000 hours +R			Lug	250 to 450	330 to 2,200	
Screw-mount Terminal Type		General Purpose	<b>SME</b>	Screw terminal, general	85°C 2,000 hours +R	●		Screw	10 to 250	560 to 680,000
			<b>KMH</b>	Screw terminal, general	105°C 2,000 hours +R	●		Screw	10 to 400	180 to 680,000
		For Inverter	<b>RWG</b> <small>(NEW)</small>	85°C, high ripple, downsized, long life	85°C 5,000 hours +R			Screw	350 to 450	1,500 to 18,000
	<b>RWF</b>		High ripple, long life	85°C 5,000 hours +R			Screw	350 to 450	820 to 22,000	
	<b>RWE</b>		High ripple	85°C 2,000 hours +R	●		Screw	350 to 550	100 to 12,000	
	<b>RWY</b>		High ripple, long life, low cost	85°C 5,000 hours +R			Screw	350 to 450	500 to 14,000	
	<b>RWL</b>		High ripple, long life	85°C 20,000 hours +R			Screw	350 to 450	2,200 to 12,000	
	<b>FTP</b>		Ellips can shape, high ripple	85°C 5,000 hours +R			Screw	63 to 450	270 to 21,000	
	<b>LXA</b>		Long life	105°C 2,000/5,000 hours +R			Screw	10 to 525	330 to 390,000	
	<b>LXR</b>		High ripple, long life	105°C 5,000 hours +R			Screw	350 to 450	2,200 to 15,000	
	<b>LWY</b>		Low cost (Ask Engineering Bulletin No714 in detail)	105°C 5,000 hours +R			Screw	350 to 450	460 to 13,000	
<b>KW</b>	Low impedance (Ask Engineering Bulletin in detail)	105°C 2,000 hours		●	Screw	10 to 100	1,000 to 100,000			

■ : Promotional products

▲ : Some of range are solvent-proof.

CONDUCTIVE POLYMER ALUMINUM SOLID CAPACITORS

◆SURFACE MOUNT

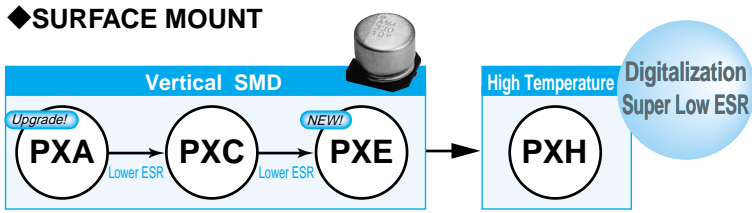

◆RADIAL LEAD

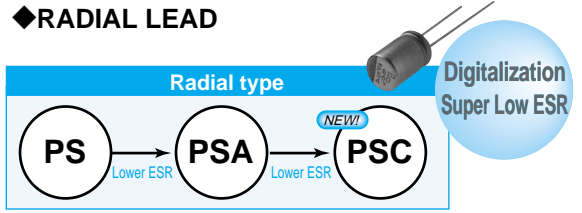

ALUMINUM ELECTROLYTIC CAPACITORS

◆SURFACE MOUNT

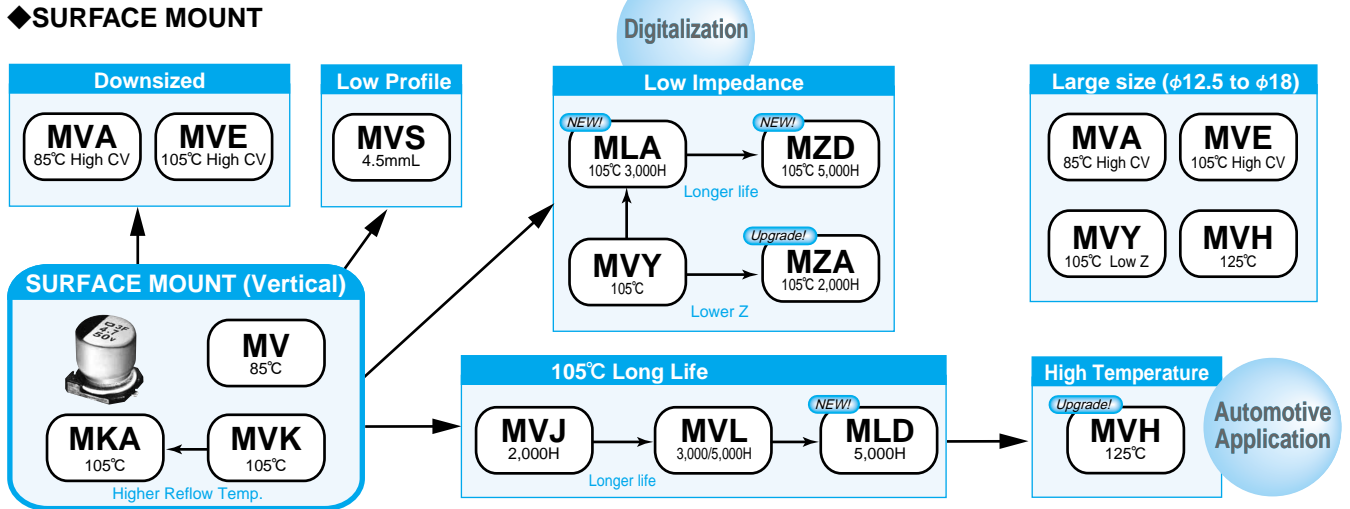

◆RADIAL LEAD

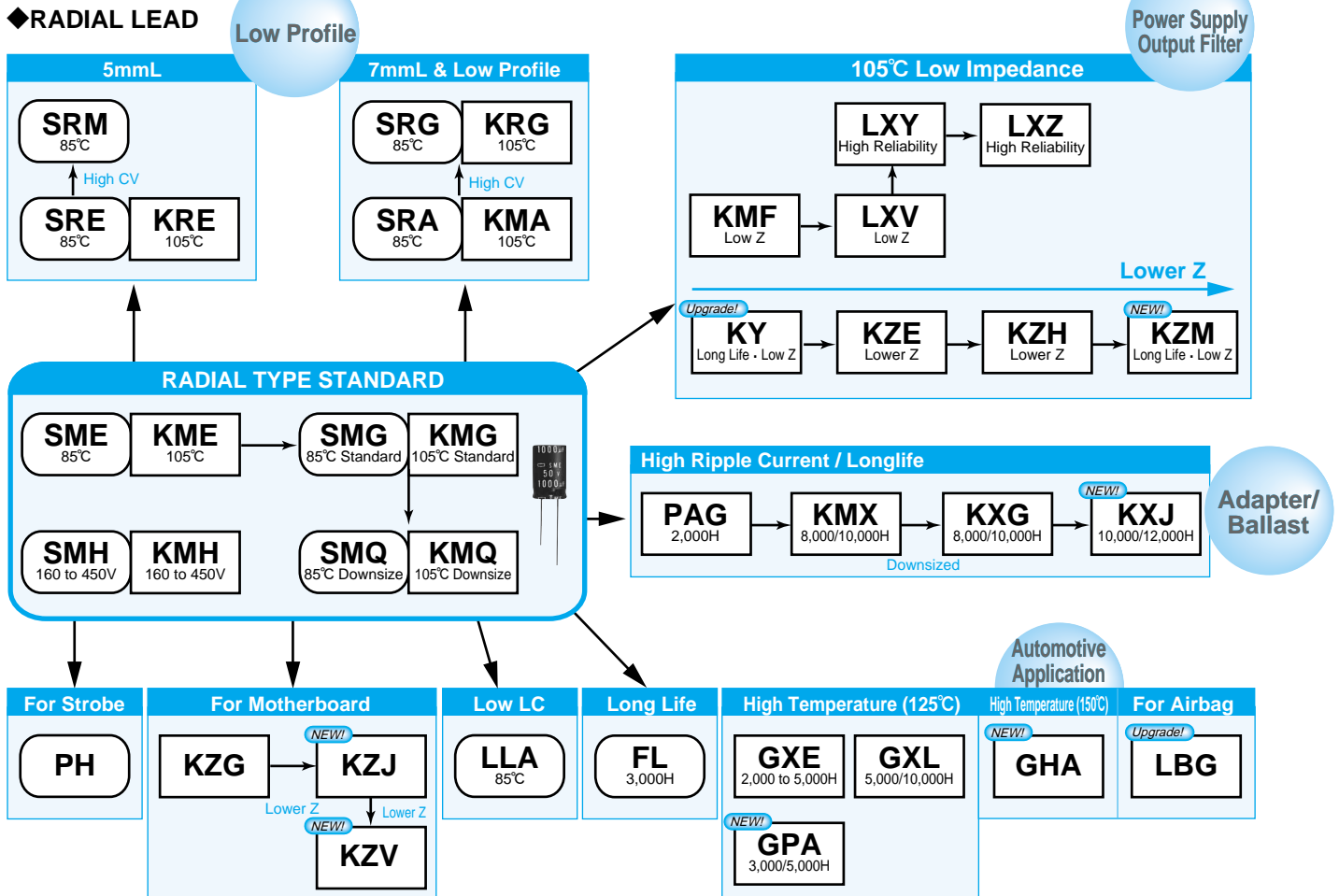

## ALUMINUM ELECTROLYTIC CAPACITORS

### ◆SNAP-IN

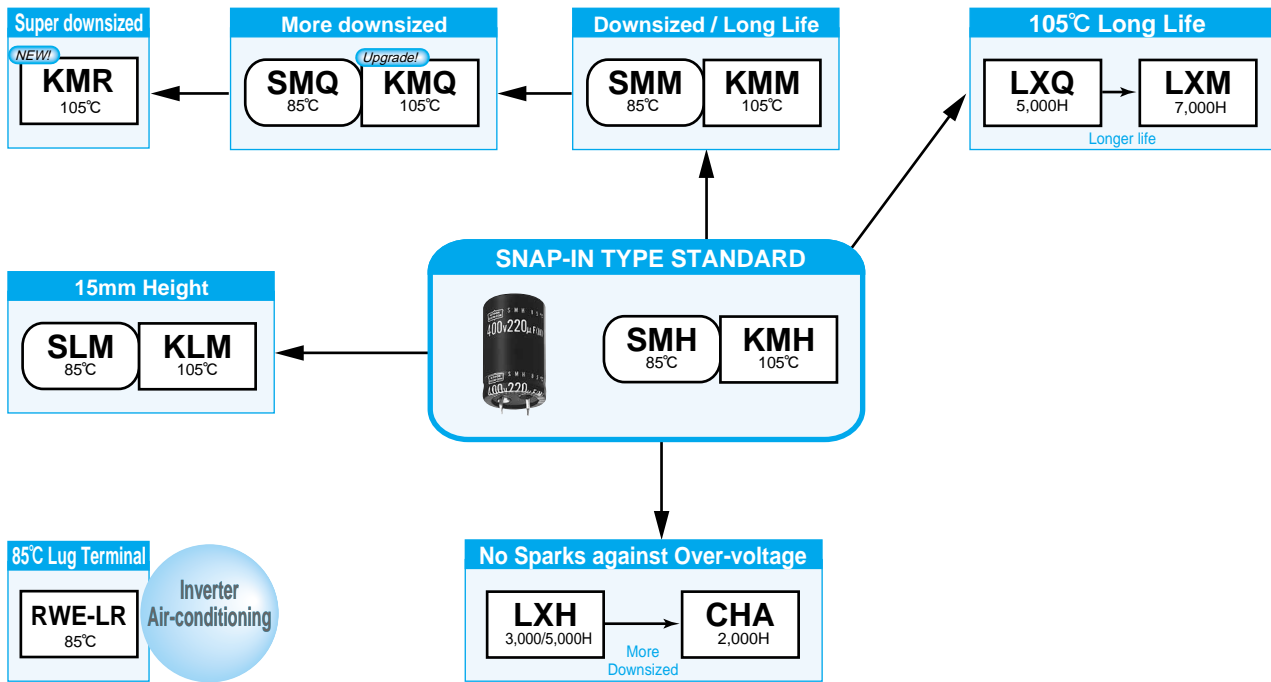

### ◆SCREW-MOUNT TERMINAL

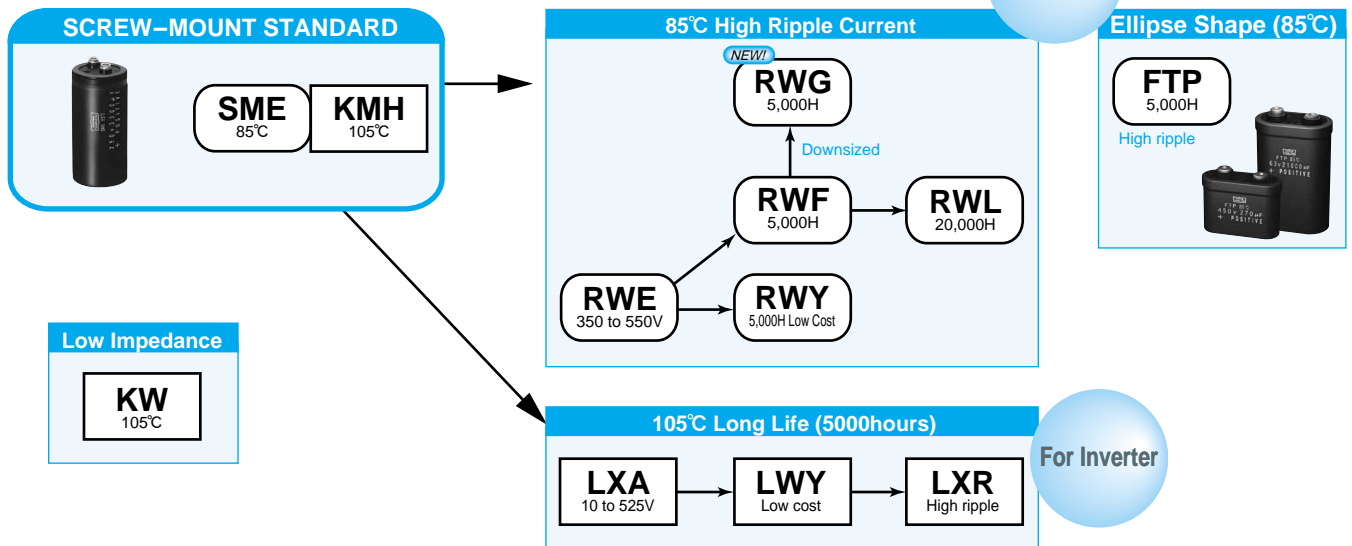

## A guide to global code (Radial lead type)

(Example : SMG series, 250V-220 $\mu$ F,  $\phi$ 18 $\times$ 40L, Straight lead with bulk)

Refer to the following table about radial lead type

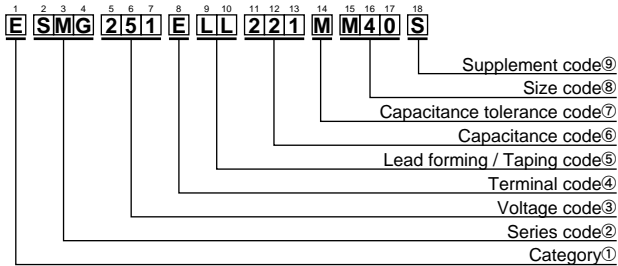

### ①Category

Type	Code 1th
Polar	E
Bi-polar	B

### ②Series code

Series name	Code		
	2th	3th	4th
SMG	S	M	G
FL	F	L	—
No series name	C	S	T

### ③Voltage code

Voltage (V)	Code		
	5th	6th	7th
4	4	R	0
6.3	6	R	3
10	1	0	0
16	1	6	0
25	2	5	0
35	3	5	0
50	5	0	0
63	6	3	0
80	8	0	0
100	1	0	1
160	1	6	1
200	2	0	1
250	2	5	1
315	3	B	1
350	3	5	1
400	4	0	1
420	4	2	1
450	4	5	1
500	5	0	1

### ④Terminal code

Type	Code 8th
Radial lead	E

### ⑤Lead forming / Taping code

Type	Contents	Code	
		9th	10th
Lead forming (Radial lead /Bulk)	Straight	L	L
	CC(3.5mm)	C	3
	CC(5.0mm)	C	5
	FC	F	C
	FM	F	M
	MC	M	C
	BC	B	C
Taping (Radial lead)	RC	R	C
	Straight	T	D
	Sloping clinch	T	D
	Straight (Skip a hole)	T	E
	Clinch (F=2.5mm)	T	A
	Clinch (F=3.5mm)	T	B
Clinch (F=5.0mm)	T	C	

Refer product guide for lead forming and taping specifications.

### ⑥Capacitance code

Cap. ( $\mu$ F)	Code		
	11th	12th	13th
0.10	R	1	0
0.22	R	2	2
0.33	R	3	3
0.47	R	4	7
0.68	R	6	8
1.0	1	R	0
2.2	2	R	2
3.3	3	R	3
4.7	4	R	7
6.8	6	R	8
10	1	0	0
22	2	2	0
33	3	3	0
47	4	7	0
68	6	8	0
100	1	0	1
220	2	2	1
330	3	3	1
470	4	7	1
680	6	8	1
1,000	1	0	2
2,200	2	2	2
3,300	3	3	2
4,700	4	7	2
6,800	6	8	2
10,000	1	0	3
22,000	2	2	3
33,000	3	3	3
47,000	4	7	3
68,000	6	8	3

### ⑦Capacitance tolerance

Tol. (%)	Code 14th
$\pm$ 20	M
$\pm$ 10	K
-10 to +30	Q
-10 to +50	T

### ⑧Size code

$\phi$ D	Code 15th
	4
5	E
6.3	F
8	H
10	J
12.5	K
14.5	U
16	L
18	M
20	N
22	P
25.4	Q

L	Code	
	16th	17th
5	0	5
7	0	7
9	0	9
11	1	1
11.5	B	5
12.0	1	2
12.5	C	5
13	1	3
15	1	5
16	1	6
20	2	0
25	2	5
30	3	0
31.5	N	3
35	3	5
35.5	P	1
40	4	0
45	4	5
50	5	0
55	5	5
60	6	0

### ⑨Supplement code

Sleeve material	Terminal plating material	Code 18th
		PET
	Sn-Bi	D
	Sn-Pb	C
Sleeveless (Coating case)	Sn-Bi	G
	Sn-Pb	F
PVC	Sn100%	B
	Sn-Bi	A
	Sn-Pb	N

\* Refer to the appendix (Global code) for codes does not listed.



# SRE Series

- 5mm height
- Endurance : 1,000 hours at 85°C
- Non solvent-proof type
- RoHS Compliant

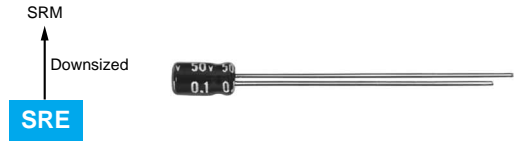

## ◆SPECIFICATIONS

Items	Characteristics								
Category	-40 to +85°C								
Temperature Range	-40 to +85°C								
Rated Voltage Range	4 to 50V <sub>dc</sub>								
Capacitance Tolerance	±20% (M) (at 20°C, 120Hz)								
Leakage Current	I=0.01CV or 3μA, whichever is greater. Where, I : Max. leakage current (μA), C : Nominal capacitance (μF), V : Rated voltage (V) (at 20°C after 2 minutes)								
Dissipation Factor (tanδ)	Rated voltage (V <sub>dc</sub> )	4V	6.3V	10V	16V	25V	35V	50V	(at 20°C, 120Hz)
	tanδ (Max.)	0.35	0.24	0.20	0.16	0.14	0.12	0.10	
Low Temperature Characteristics (Max. Impedance Ratio)	Rated voltage (V <sub>dc</sub> )	4V	6.3V	10V	16V	25V	35V	50V	(at 120Hz)
	Z(-25°C)/Z(+20°C)	7	4	3	2	2	2	2	
	Z(-40°C)/Z(+20°C)	15	10	8	6	4	3	3	
Endurance	The following specifications shall be satisfied when the capacitors are restored to 20°C after the rated voltage is applied for 1,000 hours at 85°C.								
	Capacitance change	≤±20% of the initial value							
	D.F. (tanδ)	≤200% of the initial specified value							
	Leakage current	≤The initial specified value							
Shelf Life	The following specifications shall be satisfied when the capacitors are restored to 20°C after exposing them for 1,000 hours at 85°C without voltage applied.								
	Capacitance change	≤±20% of the initial value							
	D.F. (tanδ)	≤200% of the initial specified value							
	Leakage current	≤The initial specified value							

## ◆DIMENSIONS [mm]

- Terminal Code : E

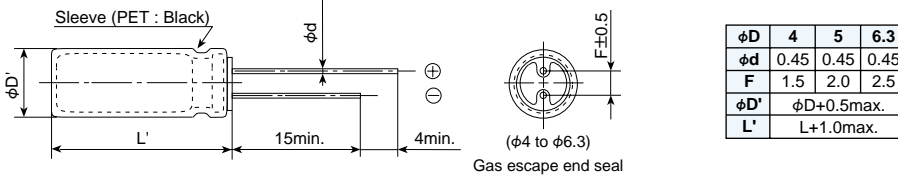

## ◆PART NUMBERING SYSTEM

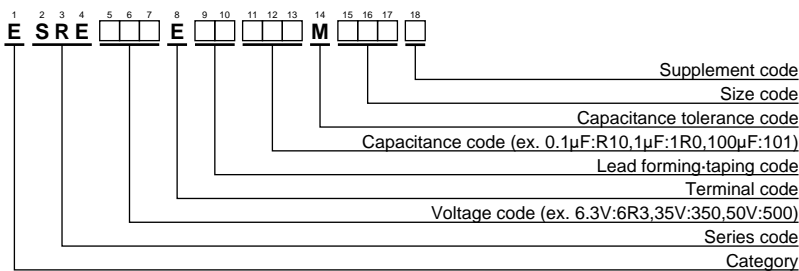

Please refer to "A guide to global code (radial lead type)"



◆STANDARD RATINGS

WV (Vdc)	Cap (μF)	Case size φDXL(mm)	tanδ	Rated ripple current (mA <sub>rms</sub> /85°C,120Hz)	Part No.	WV (Vdc)	Cap (μF)	Case size φDXL(mm)	tanδ	Rated ripple current (mA <sub>rms</sub> /85°C,120Hz)	Part No.	
4	33	4×5	0.35	23	ESRE4R0E□□330MD05D	35	2.2	4×5	0.12	8.3	ESRE350E□□2R2MD05D	
	10	4×5	0.24	12	ESRE6R3E□□100MD05D		3.3	4×5	0.12	11	ESRE350E□□3R3MD05D	
6.3	15	4×5	0.24	17	ESRE6R3E□□150MD05D		4.7	4×5	0.12	15	ESRE350E□□4R7MD05D	
	22	4×5	0.24	23	ESRE6R3E□□220MD05D		6.8	5×5	0.12	20	ESRE350E□□6R8ME05D	
	47	5×5	0.24	38	ESRE6R3E□□470ME05D		10	5×5	0.12	25	ESRE350E□□100ME05D	
	100	6.3×5	0.24	60	ESRE6R3E□□101MF05D		15	6.3×5	0.12	33	ESRE350E□□150MF05D	
10	6.8	4×5	0.20	11	ESRE100E□□6R8MD05D		22	6.3×5	0.12	40	ESRE350E□□220MF05D	
	15	4×5	0.20	20	ESRE100E□□150MD05D		50	0.10	4×5	0.10	1.3	ESRE500E□□R10MD05D
	33	5×5	0.20	35	ESRE100E□□330ME05D			0.15	4×5	0.10	2.0	ESRE500E□□R15MD05D
68	6.3×5	0.20	54	ESRE100E□□680MF05D	0.22			4×5	0.10	2.9	ESRE500E□□R22MD05D	
16	4.7	4×5	0.16	10	ESRE160E□□4R7MD05D			0.33	4×5	0.10	3.5	ESRE500E□□R33MD05D
	6.8	4×5	0.16	14	ESRE160E□□6R8MD05D			0.47	4×5	0.10	4.2	ESRE500E□□R47MD05D
	10	4×5	0.16	17	ESRE160E□□100MD05D	0.68		4×5	0.10	5.1	ESRE500E□□R68MD05D	
	15	5×5	0.16	26	ESRE160E□□150ME05D	1.0		4×5	0.10	6.2	ESRE500E□□1R0MD05D	
	22	5×5	0.16	32	ESRE160E□□220ME05D	1.5		4×5	0.10	7.5	ESRE500E□□1R5MD05D	
25	47	6.3×5	0.16	50	ESRE160E□□470MF05D	2.2		4×5	0.10	10	ESRE500E□□2R2MD05D	
	3.3	4×5	0.14	9.3	ESRE250E□□3R3MD05D	3.3		4×5	0.10	14	ESRE500E□□3R3MD05D	
	4.7	4×5	0.14	12	ESRE250E□□4R7MD05D	4.7		5×5	0.10	19	ESRE500E□□4R7ME05D	
	6.8	4×5	0.14	16	ESRE250E□□6R8MD05D	6.8		6.3×5	0.10	24	ESRE500E□□6R8MF05D	
	33	6.3×5	0.14	45	ESRE250E□□330MF05D	10	6.3×5	0.10	29	ESRE500E□□100MF05D		

□□ : Lead forming / Taping code

Note : □ had been unified to φ4×5.

# KRE Series

- 5mm height
- Endurance : 1,000 hours at 105°C
- Solvent-proof type (see PRECAUTIONS AND GUIDELINES)
- RoHS Compliant



## ◆ SPECIFICATIONS

Items	Characteristics						
Category	-55 to +105°C						
Temperature Range	-55 to +105°C						
Rated Voltage Range	6.3 to 50V <sub>dc</sub>						
Capacitance Tolerance	±20% (M) (at 20°C, 120Hz)						
Leakage Current	I=0.01CV or 3μA, whichever is greater. Where, I : Max. leakage current (μA), C : Nominal capacitance (μF), V : Rated voltage (V) (at 20°C after 2 minutes)						
Dissipation Factor (tanδ)	Rated voltage (V <sub>dc</sub> )	6.3V	10V	16V	25V	35V	50V
	tanδ (Max.)	0.27	0.23	0.19	0.15	0.13	0.11
Low Temperature Characteristics (Max. Impedance Ratio)	Rated voltage (V <sub>dc</sub> )	6.3V	10V	16V	25V	35V	50V
	Z(-25°C)/Z(+20°C)	3	3	2	2	2	2
	Z(-40°C)/Z(+20°C)	9	7	5	3	3	3
Endurance	The following specifications shall be satisfied when the capacitors are restored to 20°C after the rated voltage is applied for 1,000 hours at 105°C.						
	φD (mm)	φ4 to φ6.3					
	Capacitance change	≤±20% of the initial value					
	D.F. (tanδ)	≤200% of the initial specified value					
	Leakage current	≤The initial specified value					
Shelf Life	The following specifications shall be satisfied when the capacitors are restored to 20°C after exposing them for 500 hours at 105°C without voltage applied.						
	φD	φ4 to φ6.3					
	Capacitance change	≤±20% of the initial value					
	D.F. (tanδ)	≤200% of the initial specified value					
	Leakage current	≤The initial specified value					

## ◆ DIMENSIONS [mm]

- Terminal Code : E

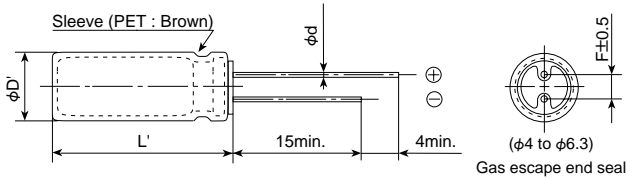

φD	4	5	6.3
φd	0.45	0.45	0.45
F	1.5	2.0	2.5
φD'	φD+0.5max.		
L'	L+1.0max.		

## ◆ PART NUMBERING SYSTEM

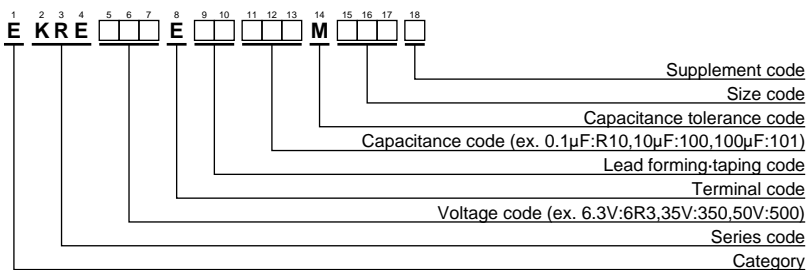

Please refer to "A guide to global code (radial lead type)"

### ◆STANDARD RATINGS

WV (V <sub>dc</sub> )	Cap (μF)	Case size φDXL(mm)	tanδ	Rated ripple current (mA <sub>rms</sub> /105°C, 120Hz)	Part No.	WV (V <sub>dc</sub> )	Cap (μF)	Case size φDXL(mm)	tanδ	Rated ripple current (mA <sub>rms</sub> /105°C, 120Hz)	Part No.
6.3	10	4×5	0.27	12	EKRE6R3E□□100MD05D	35	2.2	4×5	0.13	7.7	EKRE350E□□2R2MD05D
	15	4×5	0.27	16	EKRE6R3E□□150MD05D		3.3	4×5	0.13	11	EKRE350E□□3R3MD05D
	22	4×5	0.27	21	EKRE6R3E□□220MD05D		4.7	4×5	0.13	15	EKRE350E□□4R7MD05D
	47	5×5	0.27	36	EKRE6R3E□□470ME05D		6.8	5×5	0.13	20	EKRE350E□□6R8ME05D
	100	6.3×5	0.27	56	EKRE6R3E□□101MF05D		10	5×5	0.13	25	EKRE350E□□100ME05D
10	6.8	4×5	0.23	11	EKRE100E□□6R8MD05D	15	6.3×5	0.13	33	EKRE350E□□150MF05D	
	15	4×5	0.23	20	EKRE100E□□150MD05D	22	6.3×5	0.13	40	EKRE350E□□220MF05D	
	33	5×5	0.23	34	EKRE100E□□330ME05D	50	0.10	4×5	0.11	1.3	EKRE500E□□R10MD05D
	68	6.3×5	0.23	52	EKRE100E□□680MF05D		0.15	4×5	0.11	2.0	EKRE500E□□R15MD05D
16	4.7	4×5	0.19	9.4	EKRE160E□□4R7MD05D		0.22	4×5	0.11	2.6	EKRE500E□□R22MD05D
	6.8	4×5	0.19	13	EKRE160E□□6R8MD05D		0.33	4×5	0.11	3.2	EKRE500E□□R33MD05D
	10	4×5	0.19	16	EKRE160E□□100MD05D		0.47	4×5	0.11	3.8	EKRE500E□□R47MD05D
	15	5×5	0.19	25	EKRE160E□□150ME05D		0.68	4×5	0.11	4.6	EKRE500E□□R68MD05D
	22	5×5	0.19	30	EKRE160E□□220ME05D		1.0	4×5	0.11	5.6	EKRE500E□□1R0MD05D
47	6.3×5	0.19	48	EKRE160E□□470MF05D	1.5		4×5	0.11	6.9	EKRE500E□□1R5MD05D	
25	3.3	4×5	0.15	8.8	EKRE250E□□3R3MD05D		2.2	4×5	0.11	10	EKRE500E□□2R2MD05D
	4.7	4×5	0.15	12	EKRE250E□□4R7MD05D		3.3	4×5	0.11	14	EKRE500E□□3R3MD05D
	6.8	4×5	0.15	16	EKRE250E□□6R8MD05D		4.7	5×5	0.11	19	EKRE500E□□4R7ME05D
	33	6.3×5	0.15	45	EKRE250E□□330MF05D		6.8	6.3×5	0.11	24	EKRE500E□□6R8MF05D
							10	6.3×5	0.11	29	EKRE500E□□100MF05D

□□ : Lead forming / Taping code

Note : □ had been unified to φ4×5.

# SRA Series

- 7mm height
- Endurance : 1,000 hours at 85°C
- Non solvent-proof type
- RoHS Compliant

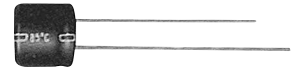
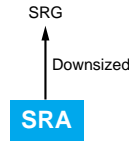

## ◆SPECIFICATIONS

Items	Characteristics									
Category	-40 to +85°C									
Temperature Range	-40 to +85°C									
Rated Voltage Range	4 to 63V <sub>dc</sub>									
Capacitance Tolerance	±20% (M) (at 20°C, 120Hz)									
Leakage Current	I=0.01CV or 3μA, whichever is greater. (at 20°C after 2 minutes)									
	Where, I : Max. leakage current (μA), C : Nominal capacitance (μF), V : Rated voltage (V)									
Dissipation Factor (tanδ)	Rated voltage (V <sub>dc</sub> )	4V	6.3V	10V	16V	25V	35V	50V	63V	
	tanδ (Max.)	0.35	0.24	0.20	0.16	0.14	0.12	0.10	0.08	(at 20°C, 120Hz)
Low Temperature Characteristics (Max. Impedance Ratio)	Rated voltage (V <sub>dc</sub> )	4V	6.3V	10V	16V	25V	35V	50V	63V	
	Z(-25°C)/Z(+20°C)	4	4	3	2	2	2	2	2	(at 120Hz)
	Z(-40°C)/Z(+20°C)	10	10	8	6	4	3	3	3	
Endurance	The following specifications shall be satisfied when the capacitors are restored to 20°C after the rated voltage is applied for 1,000 hours at 85°C.									
	Capacitance change	≤±20% of the initial value								
	D.F. (tanδ)	≤200% of the initial specified value								
	Leakage current	≤The initial specified value								
Shelf Life	The following specifications shall be satisfied when the capacitors are restored to 20°C after exposing them for 500 hours at 85°C without voltage applied.									
	Capacitance change	≤±20% of the initial value								
	D.F. (tanδ)	≤200% of the initial specified value								
	Leakage current	≤The initial specified value								

## ◆DIMENSIONS [mm]

- Terminal Code : E

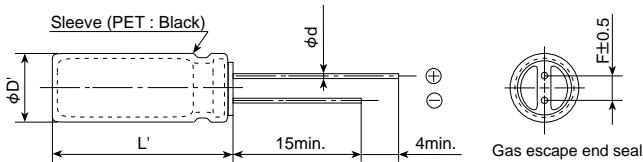

	4	5	6.3	8
φD	4	5	6.3	8
φd	0.45	0.45	0.45	0.45
F	1.5	2.0	2.5	3.5
φD'	φD+0.5max.			
L'	L+1.0max.			

## ◆PART NUMBERING SYSTEM

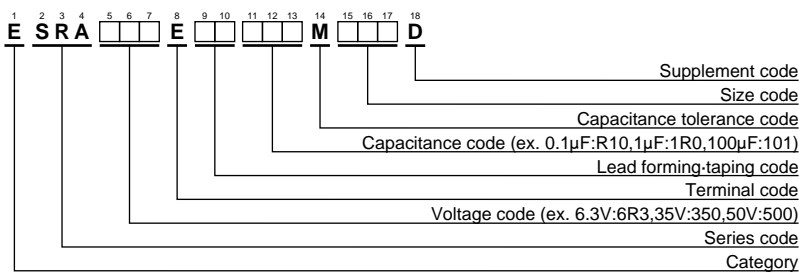

Please refer to "A guide to global code (radial lead type)"

### ◆STANDARD RATINGS

WV (Vdc)	Cap (μF)	Case size φDXL(mm)	tanδ	Rated ripple current (mA <sub>rms</sub> /85°C,120Hz)	Part No.
4	33	4×7	0.35	26	ESRA4R0E□□330MD07D
	47	4×7	0.35	34	ESRA4R0E□□470MD07D
	100	5×7	0.35	61	ESRA4R0E□□101ME07D
	220	6.3×7	0.35	95	ESRA4R0E□□221MF07D
	470	8×7	0.35	154	ESRA4R0E□□471MH07D
6.3	22	4×7	0.24	31	ESRA6R3E□□220MD07D
	47	5×7	0.24	47	ESRA6R3E□□470ME07D
	330	8×7	0.24	156	ESRA6R3E□□331MH07D
10	33	5×7	0.20	43	ESRA100E□□330ME07D
	100	6.3×7	0.20	80	ESRA100E□□101MF07D
	220	8×7	0.20	140	ESRA100E□□221MH07D
16	10	4×7	0.16	25	ESRA160E□□100MD07D
	22	5×7	0.16	39	ESRA160E□□220ME07D
	47	6.3×7	0.16	59	ESRA160E□□470MF07D
	100	6.3×7	0.16	97	ESRA160E□□101MF07D
25	33	6.3×7	0.14	53	ESRA250E□□330MF07D
	47	6.3×7	0.14	71	ESRA250E□□470MF07D
35	4.7	4×7	0.12	20	ESRA350E□□4R7MD07D
	10	5×7	0.12	30	ESRA350E□□100ME07D
	22	6.3×7	0.12	47	ESRA350E□□220MF07D
	33	6.3×7	0.12	64	ESRA350E□□330MF07D
	47	8×7	0.12	83	ESRA350E□□470MH07D

WV (Vdc)	Cap (μF)	Case size φDXL(mm)	tanδ	Rated ripple current (mA <sub>rms</sub> /85°C,120Hz)	Part No.
50	0.10	4×7	0.10	1.3	ESRA500E□□R10MD07D
	0.22	4×7	0.10	2.9	ESRA500E□□R22MD07D
	0.33	4×7	0.10	3.5	ESRA500E□□R33MD07D
	0.47	4×7	0.10	5.0	ESRA500E□□R47MD07D
	1.0	4×7	0.10	10	ESRA500E□□R10MD07D
	2.2	4×7	0.10	15	ESRA500E□□R22MD07D
	3.3	4×7	0.10	18	ESRA500E□□R33MD07D
	4.7	5×7	0.10	23	ESRA500E□□R47ME07D
	10	6.3×7	0.10	34	ESRA500E□□R100MF07D
	22	6.3×7	0.10	57	ESRA500E□□R220MF07D
	33	8×7	0.10	76	ESRA500E□□R330MH07D
63	0.10	4×7	0.08	1.3	ESRA630E□□R10MD07D
	0.22	4×7	0.08	2.9	ESRA630E□□R22MD07D
	0.33	4×7	0.08	4.4	ESRA630E□□R33MD07D
	0.47	4×7	0.08	7.9	ESRA630E□□R47MD07D
	1.0	4×7	0.08	11	ESRA630E□□R10MD07D
	2.2	4×7	0.08	17	ESRA630E□□R22MD07D
	3.3	5×7	0.08	21	ESRA630E□□R33ME07D
	4.7	6.3×7	0.08	26	ESRA630E□□R47MF07D
	10	6.3×7	0.08	47	ESRA630E□□R100MF07D

□□ : Lead forming / Taping code

# KMA Series

- 7mm height
- Endurance : 1,000 hours at 105°C
- Solvent-proof type (see PRECAUTIONS AND GUIDELINES)
- RoHS Compliant

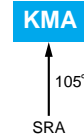

## ◆SPECIFICATIONS

Items	Characteristics										
Category	-55 to +105°C										
Temperature Range											
Rated Voltage Range	4 to 63V <sub>dc</sub>										
Capacitance Tolerance	±20% (M) (at 20°C, 120Hz)										
Leakage Current	I=0.01CV or 3μA, whichever is greater. Where, I : Max. leakage current (μA), C : Nominal capacitance (μF), V : Rated voltage (V) (at 20°C after 2 minutes)										
Dissipation Factor (tanδ)	Rated voltage (V <sub>dc</sub> )	4V	6.3V	10V	16V	25V	35V	50V	63V		
	tanδ (Max.)	0.35	0.22	0.19	0.16	0.14	0.12	0.10	0.08	(at 20°C, 120Hz)	
Low Temperature Characteristics (Max. Impedance Ratio)	Rated voltage (V <sub>dc</sub> )	4V	6.3V	10V	16V	25V	35V	50V	63V		
	Z(-25°C)/Z(+20°C)	4	3	2	2	2	2	2	2	(at 120Hz)	
	Z(-40°C)/Z(+20°C)	10	6	5	3	3	3	3	3		
Endurance	The following specifications shall be satisfied when the capacitors are restored to 20°C after the rated voltage is applied for 1,000 hours at 105°C.										
	Rated voltage	4 to 16V <sub>dc</sub>				25 to 63V <sub>dc</sub>					
	Capacitance change	≤±25% of the initial value				≤±20% of the initial value					
	D.F. (tanδ)	≤200% of the initial specified value									
	Leakage current	≤The initial specified value									
Shelf Life	The following specifications shall be satisfied when the capacitors are restored to 20°C after exposing them for 1,000 hours at 105°C without voltage applied.										
	Rated voltage	4 to 16V <sub>dc</sub>				25 to 63V <sub>dc</sub>					
	Capacitance change	≤±25% of the initial value				≤±20% of the initial value					
	D.F. (tanδ)	≤200% of the initial specified value									
	Leakage current	≤The initial specified value									

## ◆DIMENSIONS [mm]

- Terminal Code : E

Sleeve (PET : Brown)

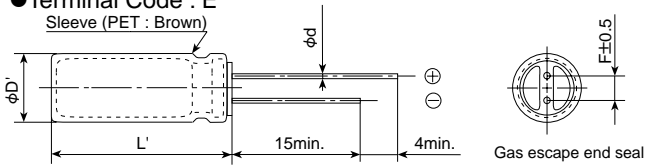

φD	4	5	6.3
φd	0.45	0.45	0.45
F	1.5	2.0	2.5
φD'	φD+0.5max.		
L'	L+1.0max.		

## ◆PART NUMBERING SYSTEM

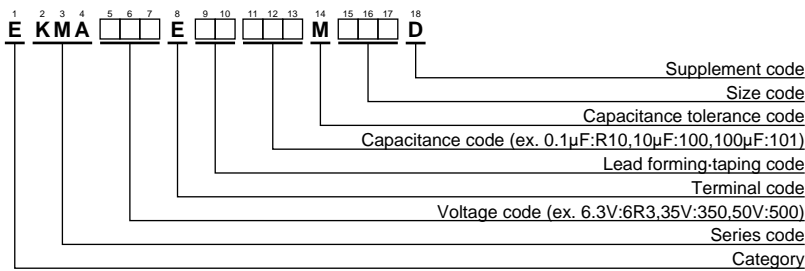

Please refer to "A guide to global code (radial lead type)"

◆STANDARD RATINGS

WV (Vdc)	Cap (μF)	Case size φDXL(mm)	tanδ	Rated ripple current (mA <sub>rms</sub> /105°C,120Hz)	Part No.	WV (Vdc)	Cap (μF)	Case size φDXL(mm)	tanδ	Rated ripple current (mA <sub>rms</sub> /105°C,120Hz)	Part No.
4	33	4X7	0.35	26	EKMA4R0E□□330MD07D	50	0.10	4X7	0.10	1.3	EKMA500E□□R10MD07D
	47	4X7	0.35	34	EKMA4R0E□□470MD07D		0.15	4X7	0.10	2.0	EKMA500E□□R15MD07D
	100	5X7	0.35	61	EKMA4R0E□□101ME07D		0.22	4X7	0.10	2.9	EKMA500E□□R22MD07D
	220	6.3X7	0.35	95	EKMA4R0E□□221MF07D		0.33	4X7	0.10	3.5	EKMA500E□□R33MD07D
6.3	22	4X7	0.22	31	EKMA6R3E□□220MD07D		0.47	4X7	0.10	5.0	EKMA500E□□R47MD07D
	47	5X7	0.22	47	EKMA6R3E□□470ME07D		0.68	4X7	0.10	7.1	EKMA500E□□R68MD07D
10	15	4X7	0.19	28	EKMA100E□□150MD07D		1.0	4X7	0.10	10	EKMA500E□□R10MD07D
	33	5X7	0.19	43	EKMA100E□□330ME07D		1.5	4X7	0.10	12	EKMA500E□□R15MD07D
	68	6.3X7	0.19	63	EKMA100E□□680MF07D		2.2	4X7	0.10	15	EKMA500E□□R22MD07D
	100	6.3X7	0.19	80	EKMA100E□□101MF07D		3.3	4X7	0.10	18	EKMA500E□□R33MD07D
16	6.8	4X7	0.16	20	EKMA160E□□6R8MD07D		4.7	5X7	0.10	23	EKMA500E□□R47ME07D
	10	4X7	0.16	25	EKMA160E□□100MD07D		6.8	6.3X7	0.10	28	EKMA500E□□R68MF07D
	15	5X7	0.16	31	EKMA160E□□150ME07D		10	6.3X7	0.10	34	EKMA500E□□100MF07D
	22	5X7	0.16	39	EKMA160E□□220ME07D		22	6.3X7	0.10	57	EKMA500E□□220MF07D
	47	6.3X7	0.16	59	EKMA160E□□470MF07D		63	0.10	4X7	0.08	1.3
100	6.3X7	0.16	97	EKMA160E□□101MF07D	0.15			4X7	0.08	1.9	EKMA630E□□R15MD07D
25	33	6.3X7	0.14	53	EKMA250E□□330MF07D	0.22		4X7	0.08	2.9	EKMA630E□□R22MD07D
	47	6.3X7	0.14	71	EKMA250E□□470MF07D	0.33		4X7	0.08	4.4	EKMA630E□□R33MD07D
35	4.7	4X7	0.12	20	EKMA350E□□4R7MD07D	0.47		4X7	0.08	7.9	EKMA630E□□R47MD07D
	6.8	5X7	0.12	24	EKMA350E□□6R8ME07D	0.68		4X7	0.08	9.2	EKMA630E□□R68MD07D
	10	5X7	0.12	30	EKMA350E□□100ME07D	1.0		4X7	0.08	11	EKMA630E□□R10MD07D
	15	6.3X7	0.12	37	EKMA350E□□150MF07D	1.5		4X7	0.08	13	EKMA630E□□R15MD07D
	22	6.3X7	0.12	47	EKMA350E□□220MF07D	2.2		4X7	0.08	17	EKMA630E□□R22MD07D
	33	6.3X7	0.12	64	EKMA350E□□330MF07D	3.3		5X7	0.08	21	EKMA630E□□R33ME07D
						4.7		6.3X7	0.08	26	EKMA630E□□R47MF07D
						10		6.3X7	0.08	43	EKMA630E□□100MF07D

□ □ : Lead forming / Taping code

# SRG Series

- Low profile :  $\phi 4 \times 7\text{mm}$  to  $\phi 18 \times 25\text{mm}$
- Endurance : 1,000 to 2,000 hours at 85°C
- Solvent-proof type (see PRECAUTIONS AND GUIDELINES)
- RoHS Compliant

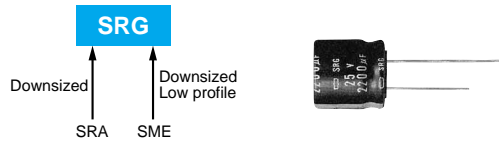

## ◆ SPECIFICATIONS

Items	Characteristics																									
Category	-40 to +85°C																									
Temperature Range	-40 to +85°C																									
Rated Voltage Range	4 to 50V <sub>dc</sub>																									
Capacitance Tolerance	±20% (M) (at 20°C, 120Hz)																									
Leakage Current	I=0.01CV or 3μA, whichever is greater. Where, I : Max. leakage current (μA), C : Nominal capacitance (μF), V : Rated voltage (V) (at 20°C after 2 minutes)																									
Dissipation Factor (tanδ)	<table border="1"> <tr> <td>Rated voltage (V<sub>dc</sub>)</td> <td>4V</td> <td>6.3V</td> <td>10V</td> <td>16V</td> <td>25V</td> <td>35V</td> <td>50V</td> </tr> <tr> <td>tanδ (Max.)</td> <td>0.38</td> <td>0.28</td> <td>0.24</td> <td>0.20</td> <td>0.16</td> <td>0.14</td> <td>0.12</td> </tr> </table> <p>When nominal capacitance exceeds 1,000μF, add 0.03 to the value above for each 1,000μF increase. (at 20°C, 120Hz)</p>		Rated voltage (V <sub>dc</sub> )	4V	6.3V	10V	16V	25V	35V	50V	tanδ (Max.)	0.38	0.28	0.24	0.20	0.16	0.14	0.12								
Rated voltage (V <sub>dc</sub> )	4V	6.3V	10V	16V	25V	35V	50V																			
tanδ (Max.)	0.38	0.28	0.24	0.20	0.16	0.14	0.12																			
Low Temperature Characteristics (Max. Impedance Ratio)	<table border="1"> <tr> <td>Rated voltage (V<sub>dc</sub>)</td> <td>4V</td> <td>6.3V</td> <td>10V</td> <td>16V</td> <td>25V</td> <td>35V</td> <td>50V</td> </tr> <tr> <td>Z(-25°C)/Z(+20°C)</td> <td>6</td> <td>5</td> <td>4</td> <td>3</td> <td>2</td> <td>2</td> <td>2</td> </tr> <tr> <td>Z(-40°C)/Z(+20°C)</td> <td>12</td> <td>12</td> <td>10</td> <td>8</td> <td>5</td> <td>4</td> <td>3</td> </tr> </table> <p>(at 120Hz)</p>		Rated voltage (V <sub>dc</sub> )	4V	6.3V	10V	16V	25V	35V	50V	Z(-25°C)/Z(+20°C)	6	5	4	3	2	2	2	Z(-40°C)/Z(+20°C)	12	12	10	8	5	4	3
Rated voltage (V <sub>dc</sub> )	4V	6.3V	10V	16V	25V	35V	50V																			
Z(-25°C)/Z(+20°C)	6	5	4	3	2	2	2																			
Z(-40°C)/Z(+20°C)	12	12	10	8	5	4	3																			
Endurance	<p>The following specifications shall be satisfied when the capacitors are restored to 20°C after the rated voltage is applied for 2,000 hours (1,000 hours for <math>\phi 8</math> and smaller) at 85°C.</p> <table border="1"> <tr> <td>Capacitance change</td> <td>≤±20% of the initial value</td> </tr> <tr> <td>D.F. (tanδ)</td> <td>≤200% of the initial specified value</td> </tr> <tr> <td>Leakage current</td> <td>≤The initial specified value</td> </tr> </table>		Capacitance change	≤±20% of the initial value	D.F. (tanδ)	≤200% of the initial specified value	Leakage current	≤The initial specified value																		
Capacitance change	≤±20% of the initial value																									
D.F. (tanδ)	≤200% of the initial specified value																									
Leakage current	≤The initial specified value																									
Shelf Life	<p>The following specifications shall be satisfied when the capacitors are restored to 20°C after exposing them for 1,000 hours at 85°C without voltage applied.</p> <table border="1"> <tr> <td>Capacitance change</td> <td>≤±20% of the initial value</td> </tr> <tr> <td>D.F. (tanδ)</td> <td>≤200% of the initial specified value</td> </tr> <tr> <td>Leakage current</td> <td>≤The initial specified value</td> </tr> </table>		Capacitance change	≤±20% of the initial value	D.F. (tanδ)	≤200% of the initial specified value	Leakage current	≤The initial specified value																		
Capacitance change	≤±20% of the initial value																									
D.F. (tanδ)	≤200% of the initial specified value																									
Leakage current	≤The initial specified value																									

## ◆ DIMENSIONS [mm]

- Terminal Code : E

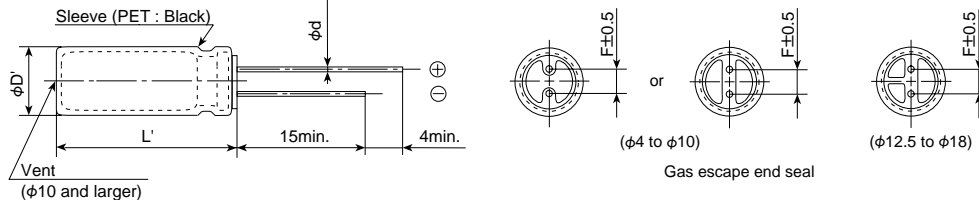

φD	4	5	6.3	8	10 & 12.5	16 & 18
7L	0.45	0.45	0.45	0.45	—	—
φd	≥9L	—	0.5	0.5	0.6	0.6
F	1.5	2.0	2.5	3.5	5.0	7.5
φD'	φD+0.5max.					
L'	L+1.5max. (7L : L+1.0max.)					

## ◆ PART NUMBERING SYSTEM

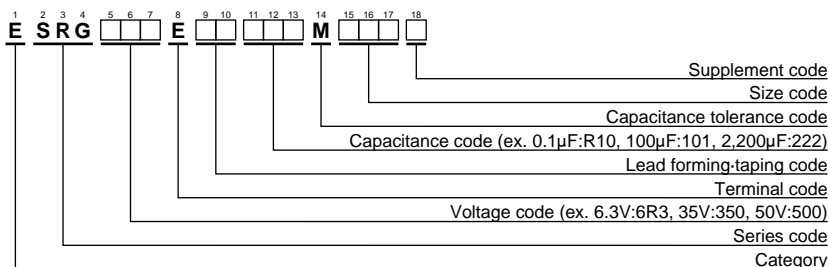

Please refer to "A guide to global code (radial lead type)"





◆STANDARD RATINGS

WV (Vdc)	Cap (μF)	Case code φD×L(mm)	tanδ	Rated ripple current (mAmps/85°C,120Hz)	Part No.	WV (Vdc)	Cap (μF)	Case code φD×L(mm)	tanδ	Rated ripple current (mAmps/85°C,120Hz)	Part No.	
4	470	8×7	0.38	154	ESRG4R0E□□471MH07D	25	2,200	18×15	0.19	1,360	ESRG250E□□222MM15S	
	47	4×7	0.28	50	ESRG6R3E□□470MD07D		3,300	18×20	0.22	1,720	ESRG250E□□332MM20S	
	100	5×7	0.28	87	ESRG6R3E□□101ME07D		4,700	18×25	0.25	2,070	ESRG250E□□472MM25S	
	220	6.3×7	0.28	133	ESRG6R3E□□221MF07D		35	10	4×7	0.14	32	ESRG350E□□100MD07D
	330	6.3×9	0.28	247	ESRG6R3E□□331MF09D			22	5×7	0.14	57	ESRG350E□□220ME07D
	330	8×7	0.28	191	ESRG6R3E□□331MH07D			33	5×9	0.14	94	ESRG350E□□330ME09D
	1,000	10×9	0.28	505	ESRG6R3E□□330MJ09S			33	6.3×7	0.14	73	ESRG350E□□331MJ09D
	4,700	16×15	0.37	1,410	ESRG6R3E□□472ML15S			47	8×7	0.14	101	ESRG350E□□470MH07D
	6,800	18×15	0.43	1,660	ESRG6R3E□□682MM15S			100	8×9	0.14	220	ESRG350E□□101MH09D
	10,000	18×20	0.55	2,020	ESRG6R3E□□103MM20S			220	10×9	0.14	335	ESRG350E□□221MJ09S
6.3	33	4×7	0.24	46	ESRG100E□□330MD07D	330		10×12.5	0.14	475	ESRG350E□□331MJ09D	
	100	5×9	0.24	132	ESRG100E□□101ME09D	470		12.5×13	0.14	585	ESRG350E□□471MK13S	
	220	6.3×9	0.24	218	ESRG100E□□221MF09D	1,000		16×15	0.14	1,010	ESRG350E□□102ML15S	
	220	8×7	0.24	171	ESRG100E□□221MH07D	2,200	18×20	0.17	1,560	ESRG350E□□222MM20S		
	470	8×9	0.24	385	ESRG100E□□471MH09D	50	0.10	4×7	0.12	1.3	ESRG500E□□R10MD07D	
	1,000	10×12.5	0.24	625	ESRG100E□□102MJC5S		0.22	4×7	0.12	2.9	ESRG500E□□R22MD07D	
	2,200	12.5×15	0.27	970	ESRG100E□□222MK15S		0.33	4×7	0.12	3.5	ESRG500E□□R33MD07D	
	3,300	16×15	0.30	1,310	ESRG100E□□332ML15S		0.47	4×7	0.12	5.0	ESRG500E□□R47MD07D	
	4,700	18×15	0.33	1,560	ESRG100E□□472MM15S		1.0	4×7	0.12	10	ESRG500E□□1R0MD07D	
	6,800	18×20	0.39	1,870	ESRG100E□□682MM20S		1.0	5×9	0.12	13	ESRG500E□□1R0ME09D	
10,000	18×25	0.51	2,370	ESRG100E□□103MM25S	2.2		4×7	0.12	15	ESRG500E□□2R2MD07D		
10	22	4×7	0.20	42	ESRG160E□□220MD07D		2.2	5×9	0.12	26	ESRG500E□□2R2ME09D	
	47	5×7	0.20	73	ESRG160E□□470ME07D		3.3	4×7	0.12	19	ESRG500E□□3R3MD07D	
	100	6.3×7	0.20	110	ESRG160E□□101MF07D		3.3	5×9	0.12	32	ESRG500E□□3R3ME09D	
	220	8×9	0.20	290	ESRG160E□□221MH09D	4.7	4×7	0.12	24	ESRG500E□□4R7MD07D		
	330	8×9	0.20	355	ESRG160E□□331MH09D	4.7	5×9	0.12	38	ESRG500E□□4R7ME09D		
	470	10×9	0.20	410	ESRG160E□□471MJ09S	10	5×7	0.12	42	ESRG500E□□100ME07D		
	1,000	12.5×13	0.20	715	ESRG160E□□102MK13S	10	5×9	0.12	64	ESRG500E□□100ME09D		
	2,200	16×15	0.23	1,160	ESRG160E□□222ML15S	22	5×9	0.12	86	ESRG500E□□220ME09D		
	3,300	18×15	0.26	1,460	ESRG160E□□332MM15S	22	6.3×7	0.12	64	ESRG500E□□220MF07D		
	4,700	18×20	0.29	1,770	ESRG160E□□472MM20S	33	6.3×9	0.12	113	ESRG500E□□330MF09D		
16	6,800	18×25	0.35	2,170	ESRG160E□□682MM25S	33	8×7	0.12	93	ESRG500E□□330MH07D		
	33	5×7	0.16	66	ESRG250E□□330ME07D	47	6.3×9	0.12	135	ESRG500E□□470MF09D		
	47	5×9	0.16	105	ESRG250E□□470ME09D	100	10×9	0.12	240	ESRG500E□□101MJ09S		
	100	6.3×7	0.16	80	ESRG250E□□470MF07D	220	10×12.5	0.12	415	ESRG500E□□221MJC5S		
	220	6.3×9	0.16	172	ESRG250E□□101MF09D	330	12.5×13	0.12	525	ESRG500E□□331MK13S		
	330	10×9	0.16	380	ESRG250E□□331MJ09S	470	16×15	0.12	745	ESRG500E□□471ML15S		
	470	10×12.5	0.16	525	ESRG250E□□471MJC5S	1,000	18×20	0.12	1,160	ESRG500E□□102MM20S		
	1,000	12.5×15	0.16	830	ESRG250E□□102MK15S							

□□ : Lead forming / Taping code

◆RATED RIPPLE CURRENT MULTIPLIERS

●Frequency Multipliers

Capacitance (μF)	Frequency (Hz)						
	50	120	300	1k	10k	100k	
to 4.7	0.65	1.00	1.35	1.75	2.30	2.50	
10 to 47	0.75	1.00	1.25	1.50	1.75	1.80	
100 to 1,000	0.80	1.00	1.15	1.30	1.40	1.50	
2,200 to	0.85	1.00	1.03	1.05	1.08	1.08	

# KRG Series

- Low profile :  $\phi 4 \times 7\text{mm}$  to  $\phi 18 \times 25\text{mm}$
- Endurance : 1,000 hours at 105°C
- Solvent-proof type (see PRECAUTIONS AND GUIDELINES)
- RoHS Compliant

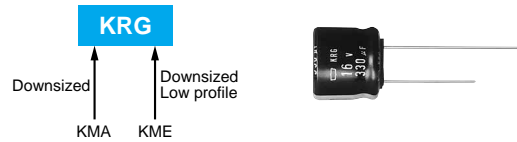

## ◆ SPECIFICATIONS

Items	Characteristics							
Category Temperature Range	-55 to +105°C							
Rated Voltage Range	6.3 to 50V <sub>dc</sub>							
Capacitance Tolerance	±20% (M) (at 20°C, 120Hz)							
Leakage Current	I=0.01CV or 3µA, whichever is greater. Where, I : Max. leakage current (µA), C : Nominal capacitance (µF), V : Rated voltage (V) (at 20°C after 2 minutes)							
Dissipation Factor (tanδ)	Rated voltage (V <sub>dc</sub> )	6.3V	10V	16V	25V	35V	50V	
	tanδ (Max.)	0.28	0.24	0.20	0.16	0.14	0.12	
	When nominal capacitance exceeds 1,000µF, add 0.03 to the value above for each 1,000µF increase. (at 20°C, 120Hz)							
Low Temperature Characteristics (Max. Impedance Ratio)	Rated voltage (V <sub>dc</sub> )	6.3V	10V	16V	25V	35V	50V	
	Z(-25°C)/Z(+20°C)	5	4	3	2	2	2	
	Z(-40°C)/Z(+20°C)	10	8	6	4	3	3	
Endurance	The following specifications shall be satisfied when the capacitors are restored to 20°C after the rated voltage is applied for 1,000 hours at 105°C.							
	Rated voltage	6.3 to 16V <sub>dc</sub>			25 to 50V <sub>dc</sub>			
	Capacitance change	≤±25% of the initial value			≤±20% of the initial value			
	D.F. (tanδ)	≤200% of the initial specified value			≤200% of the initial specified value			
	Leakage current	≤The initial specified value			≤The initial specified value			
Shelf Life	The following specifications shall be satisfied when the capacitors are restored to 20°C after exposing them for 500 hours at 105°C without voltage applied.							
	Rated voltage	6.3 to 16V <sub>dc</sub>			25 to 50V <sub>dc</sub>			
	Capacitance change	≤±25% of the initial value			≤±20% of the initial value			
	D.F. (tanδ)	≤200% of the initial specified value			≤200% of the initial specified value			
	Leakage current	≤The initial specified value			≤The initial specified value			

## ◆ DIMENSIONS [mm]

- Terminal Code : E

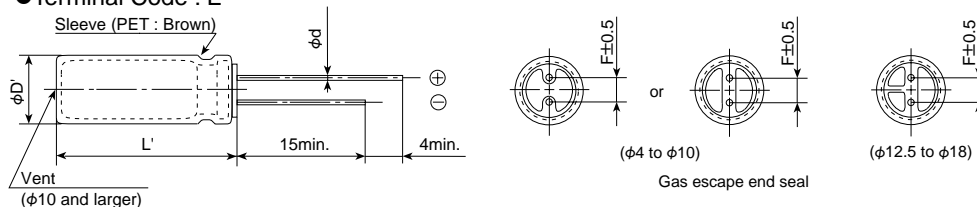

$\phi D$	4	5	6.3	8	10 & 12.5	16 & 18
$\phi d$	0.45	0.45	0.45	-	-	-
$\phi d$	0.45	0.5	0.5	0.6	0.6	0.8
F	1.5	2.0	2.5	3.5	5.0	7.5
$\phi D'$	$\phi D + 0.5\text{max.}$					
$L'$	$L + 1.5\text{max.}$ (7L : $L + 1.0\text{max.}$ )					

## ◆ PART NUMBERING SYSTEM

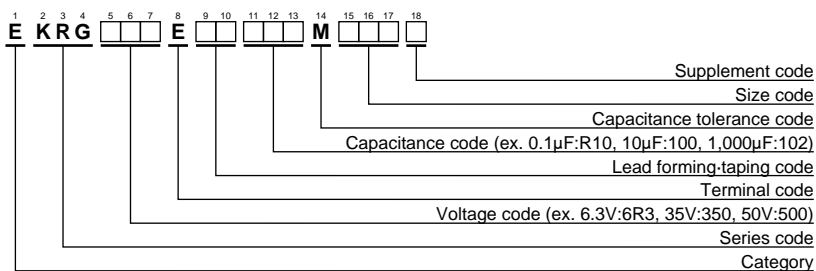

Please refer to "A guide to global code (radial lead type)"

◆STANDARD RATINGS

WV (Vdc)	Cap (μF)	Case size φDXL(mm)	tanδ	Rated ripple current (mAmps/105°C,120Hz)	Part No.	WV (Vdc)	Cap (μF)	Case size φDXL(mm)	tanδ	Rated ripple current (mAmps/105°C,120Hz)	Part No.
6.3	47	5×7	0.28	50	EKRG6R3E□□470ME07D	25	2,200	18×15	0.19	970	EKRG250E□□222MM15S
	330	6.3×9	0.28	175	EKRG6R3E□□331MF09D		3,300	18×20	0.22	1,220	EKRG250E□□332MM20S
	1,000	10×9	0.28	365	EKRG6R3E□□102MJ09S		4,700	18×25	0.25	1,470	EKRG250E□□472MM25S
	4,700	16×15	0.37	1,010	EKRG6R3E□□472ML15S		35	10	5×7	0.14	36
	6,800	18×15	0.43	1,190	EKRG6R3E□□682MM15S	22		6.3×7	0.14	57	EKRG350E□□220MF07D
10,000	18×20	0.55	1,440	EKRG6R3E□□103MM20S	33	5×9		0.14	67	EKRG350E□□330ME09D	
10	22	4×7	0.24	35	EKRG100E□□470MF07D	33		6.3×7	0.14	64	EKRG350E□□330MF07D
	100	5×9	0.24	93	EKRG100E□□101ME09D	100		8×9	0.14	155	EKRG350E□□101MH09D
	100	6.3×7	0.24	80	EKRG100E□□101MF07D	220		10×9	0.14	235	EKRG350E□□221MJ09S
	220	6.3×9	0.24	154	EKRG100E□□221MF09D	330		10×12.5	0.14	340	EKRG350E□□331MJC5S
	470	8×9	0.24	272	EKRG100E□□471MH09D	470		12.5×13	0.14	415	EKRG350E□□471MK13S
	1,000	10×12.5	0.24	445	EKRG100E□□102MJC5S	1,000		16×15	0.14	720	EKRG350E□□102ML15S
	2,200	12.5×15	0.27	690	EKRG100E□□222MK15S	2,200		18×20	0.17	1,110	EKRG350E□□222MM20S
	3,300	16×15	0.30	940	EKRG100E□□332ML15S	50	0.10	4×7	0.12	1.3	EKRG500E□□R10MD07D
	4,700	18×15	0.33	1,120	EKRG100E□□472MM15S		0.22	4×7	0.12	2.9	EKRG500E□□R22MD07D
	6,800	18×20	0.39	1,330	EKRG100E□□682MM20S		0.33	4×7	0.12	3.5	EKRG500E□□R33MD07D
10,000	18×25	0.51	1,700	EKRG100E□□103MM25S	0.47		4×7	0.12	5.0	EKRG500E□□R47MD07D	
16	33	5×7	0.20	53	EKRG160E□□330ME07D		1.0	4×7	0.12	10	EKRG500E□□1R0MD07D
	47	6.3×7	0.20	68	EKRG160E□□470MF07D		1.0	5×9	0.12	12	EKRG500E□□1R0ME09D
	100	6.3×7	0.20	97	EKRG160E□□101MF07D		2.2	4×7	0.12	15	EKRG500E□□2R2MD07D
	220	8×9	0.20	205	EKRG160E□□221MH09D		2.2	5×9	0.12	18	EKRG500E□□2R2ME09D
	330	8×9	0.20	251	EKRG160E□□331MH09D		3.3	4×7	0.12	18	EKRG500E□□3R3MD07D
	470	10×9	0.20	290	EKRG160E□□471MJ09S		3.3	5×9	0.12	22	EKRG500E□□3R3ME09D
	1,000	12.5×13	0.20	515	EKRG160E□□102MK13S		4.7	4×7	0.12	25	EKRG500E□□4R7MD07D
	2,200	16×15	0.23	830	EKRG160E□□222ML15S		4.7	5×9	0.12	27	EKRG500E□□4R7ME09D
	3,300	18×15	0.26	1,050	EKRG160E□□332MM15S		10	5×9	0.12	46	EKRG500E□□100ME09D
	4,700	18×20	0.29	1,260	EKRG160E□□472MM20S		10	6.3×7	0.12	44	EKRG500E□□100MF07D
25	6,800	18×25	0.35	1,560	EKRG160E□□682MM25S		22	5×9	0.12	61	EKRG500E□□220ME09D
	10	4×7	0.16	30	EKRG250E□□100MD07D	22	6.3×7	0.12	57	EKRG500E□□220MF07D	
	22	5×7	0.16	46	EKRG250E□□220ME07D	33	6.3×9	0.12	80	EKRG500E□□330MF09D	
	33	6.3×7	0.16	63	EKRG250E□□330MF07D	47	6.3×9	0.12	95	EKRG500E□□470MF09D	
	47	5×9	0.16	75	EKRG250E□□470ME09D	100	10×9	0.12	170	EKRG500E□□101MJ09S	
	47	6.3×7	0.16	71	EKRG250E□□470MF07D	220	10×12.5	0.12	290	EKRG500E□□221MJC5S	
	100	6.3×9	0.16	121	EKRG250E□□101MF09D	330	12.5×13	0.12	370	EKRG500E□□331MK13S	
	330	10×9	0.16	270	EKRG250E□□331MJ09S	470	16×15	0.12	535	EKRG500E□□471ML15S	
	470	10×12.5	0.16	370	EKRG250E□□471MJC5S	1,000	18×20	0.12	830	EKRG500E□□102MM20S	
	1,000	12.5×15	0.16	590	EKRG250E□□102MK15S						

□□ : Lead forming / Taping code

◆RATED RIPPLE CURRENT MULTIPLIERS

●Frequency Multipliers

Capacitance (μF)	Frequency (Hz)					
	50	120	300	1k	10k	100k
0.1 to 4.7	0.65	1.00	1.35	1.75	2.30	2.50
10 to 47	0.75	1.00	1.25	1.50	1.75	1.80
100 to 1,000	0.80	1.00	1.15	1.30	1.40	1.50
2,200 to	0.85	1.00	1.03	1.05	1.08	1.08

# SMQ Series

- Downsized from current standard SMG series
- Endurance : 2,000 hours at 85°C
- Non Solvent-proof type
- RoHS Compliant

SMQ

↑ Downsized  
SMG



## ◆ SPECIFICATIONS

Items	Characteristics														
Category Temperature Range	-40 to +85°C(6.3 to 400V <sub>dc</sub> ) -25 to +85°C(450V <sub>dc</sub> )														
Rated Voltage Range	6.3 to 450V <sub>dc</sub>														
Capacitance Tolerance	±20% (M) (at 20°C, 120Hz)														
Leakage Current	6.3 to 100V <sub>dc</sub>						160 to 450V <sub>dc</sub>								
	≤φ18	I=0.03CV or 4μA, whichever is greater.													
												CV \ Time After 1 minute			
											CV ≤ 1,000	I=0.1CV+40 max.			
											CV > 1,000	I=0.04CV+100 max.			
≥φ20	I=0.03CV (at 20C after 1 minute)											(at 20°C)			
													(at 20°C after 3 minutes)		
													Where, I : Max. leakage current (μA), C : Nominal capacitance (μF), V : Rated voltage (V)		
Dissipation Factor (tanδ)	Rated voltage (V <sub>dc</sub> )	6.3V	10V	16V	25V	35V	50V	63V	100V	160 to 250V	315 to 400V	450V			
	tanδ (Max.)	0.28	0.24	0.20	0.16	0.14	0.12	0.09	0.08	0.20	0.24	0.24			
													When nominal capacitance exceeds 1,000μF, add 0.02 to the value above for each 1,000μF increase. (at 20°C, 120Hz)		
Low Temperature Characteristics (Max. Impedance Ratio)	Rated voltage (V <sub>dc</sub> )	6.3V	10V	16V	25V	35V	50V	63V	100V	160 to 200V	250V	350V	400V	450V	
	Z(-25°C)/Z(+20°C)	≤φ8	5	4	3	2	2	2	2	2	3	3	4	4	6
		≥φ10	5	4	3	2	2	2	2	2	3	3	4	4	6
	Z(-40°C)/Z(+20°C)	≤φ8	12	10	8	5	4	3	3	3	8	10	8	8	—
≥φ10		12	10	8	5	4	3	3	3	4	4	6	6	—	
													(at 120Hz)		
Endurance	The following specifications shall be satisfied when the capacitors are restored to 20°C after the rated voltage is applied for 2,000 hours at 85°C.														
	Capacitance change	≤±20% of the initial value													
	D.F. (tanδ)	≤200% of the initial specified value													
	Leakage current	≤The initial specified value													
Shelf Life	The following specifications shall be satisfied when the capacitors are restored to 20°C after exposing them for 1,000 hours at 85°C without voltage applied.														
	Rated voltage	6.3 to 100V <sub>dc</sub>						160 to 450V <sub>dc</sub>							
	Capacitance change	≤±20% of the initial value						≤±20% of the initial value							
	D.F. (tanδ)	≤200% of the initial specified value						≤200% of the initial specified value							
	Leakage current	≤The initial specified value						≤500% of the initial specified value							

## ◆ DIMENSIONS [mm]

● Terminal Code : E

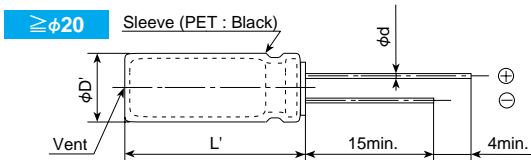
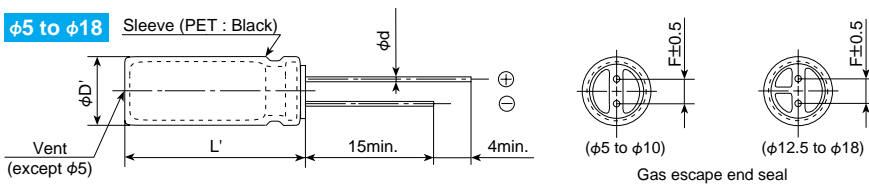

φD	5	6.3	8	10	12.5	16	18	20	22
φd	0.5	0.5	0.6	0.6	0.6	0.8	0.8	1.0	1.0
F	2.0	2.5	3.5	5.0	5.0	7.5	7.5	10.0	10.0
φD'	φD+0.5max.							φD+0.5max.	
L'	L+1.5max.							L+2.0max.	

## ◆ PART NUMBERING SYSTEM

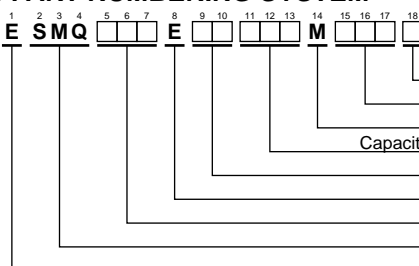

Supplement code  
Size code  
Capacitance tolerance code  
Capacitance code (ex. 0.1μF:R10, 10μF:100, 100μF:101)  
Lead forming-taping code  
Terminal code  
Voltage code (ex. 6.3V:6R3, 50V:500, 100V:101)  
Series code  
Category

Please refer to "A guide to global code (radial lead type)"



## ◆STANDARD RATINGS

WV (Vdc)	Cap (μF)	Case size φD×L(mm)	tanδ	Rated ripple current (mArms/85°C,120Hz)	Part No.	WV (Vdc)	Cap (μF)	Case size φD×L(mm)	tanδ	Rated ripple current (mArms/85°C,120Hz)	Part No.
6.3	1,000	8×11.5	0.28	540	ESMQ6R3E□□102MHB5D	50	47	6.3×11	0.12	155	ESMQ500E□□470MF11D
	2,200	10×16	0.30	890	ESMQ6R3E□□222MJ16S		68	6.3×11	0.12	210	ESMQ500E□□680MF11D
	3,300	10×20	0.32	1,190	ESMQ6R3E□□332MJ20S		100	8×11.5	0.12	260	ESMQ500E□□101MHB5D
	4,700	12.5×20	0.34	1,550	ESMQ6R3E□□472MK20S		220	10×12.5	0.12	430	ESMQ500E□□221MJ20S
	6,800	12.5×25	0.38	1,920	ESMQ6R3E□□682MK25S		330	10×16	0.12	590	ESMQ500E□□331MJ16S
	10,000	16×25	0.46	2,350	ESMQ6R3E□□103ML25S		470	10×20	0.12	760	ESMQ500E□□471MJ20S
	15,000	16×31.5	0.56	2,550	ESMQ6R3E□□153MLN3S		1,000	12.5×25	0.12	1,350	ESMQ500E□□102MK25S
	22,000	18×35.5	0.70	3,200	ESMQ6R3E□□223MMP1S		2,200	16×31.5	0.14	1,980	ESMQ500E□□222MLN3S
	33,000	20×40	0.92	3,500	ESMQ6R3E□□333MN40S		3,300	18×35.5	0.16	2,500	ESMQ500E□□332MMP1S
	47,000	22×50	1.20	3,900	ESMQ6R3E□□473MP50S		4,700	20×40	0.18	2,900	ESMQ500E□□472MN40S
10	220	5×11	0.24	240	ESMQ100E□□221ME11D	6,800	22×50	0.22	3,500	ESMQ500E□□682MP50S	
	330	6.3×11	0.24	290	ESMQ100E□□331MF11D	22	5×11	0.09	100	ESMQ630E□□220ME11D	
	470	6.3×11	0.24	350	ESMQ100E□□471MF11D	33	6.3×11	0.09	140	ESMQ630E□□330MF11D	
	1,000	10×12.5	0.24	650	ESMQ100E□□102MJC5S	47	6.3×11	0.09	170	ESMQ630E□□470MF11D	
	2,200	10×16	0.26	990	ESMQ100E□□222MJ16S	68	8×11.5	0.09	220	ESMQ630E□□680MHB5D	
	3,300	12.5×20	0.28	1,450	ESMQ100E□□332MK20S	100	8×11.5	0.09	280	ESMQ630E□□101MHB5D	
	4,700	12.5×25	0.30	1,800	ESMQ100E□□472MK25S	220	10×16	0.09	490	ESMQ630E□□221MJ16S	
	6,800	16×25	0.34	2,250	ESMQ100E□□682ML25S	330	10×20	0.09	710	ESMQ630E□□331MJ20S	
	10,000	16×31.5	0.42	2,550	ESMQ100E□□103MLN3S	470	12.5×20	0.09	900	ESMQ630E□□471MK20S	
	15,000	16×35.5	0.52	2,880	ESMQ100E□□153MLP1S	1,000	16×25	0.09	1,300	ESMQ630E□□102ML25S	
16	22,000	18×40	0.66	3,400	ESMQ100E□□223MMP40S	2,200	18×35.5	0.11	2,300	ESMQ630E□□222MMP1S	
	33,000	22×50	0.88	4,500	ESMQ100E□□333MP50S	3,300	20×40	0.13	2,700	ESMQ630E□□332MN40S	
	220	6.3×11	0.20	260	ESMQ160E□□221MF11D	4,700	22×50	0.15	3,400	ESMQ630E□□472MP50S	
	330	6.3×11	0.20	320	ESMQ160E□□331MF11D	0.10	5×11	0.08	2.1	ESMQ101E□□R10ME11D	
	470	8×11.5	0.20	440	ESMQ160E□□471MHB5D	0.22	5×11	0.08	4.7	ESMQ101E□□R22ME11D	
	1,000	10×12.5	0.20	700	ESMQ160E□□102MJC5S	0.33	5×11	0.08	7.0	ESMQ101E□□R33ME11D	
	2,200	10×20	0.22	1,000	ESMQ160E□□222MJ20S	0.47	5×11	0.08	10	ESMQ101E□□R47ME11D	
	3,300	12.5×25	0.24	1,700	ESMQ160E□□332MK25S	1.0	5×11	0.08	21	ESMQ101E□□1R0ME11D	
	4,700	16×25	0.26	2,100	ESMQ160E□□472ML25S	2.2	5×11	0.08	30	ESMQ101E□□2R2ME11D	
	6,800	16×25	0.30	2,250	ESMQ160E□□682ML25S	3.3	5×11	0.08	40	ESMQ101E□□3R3ME11D	
25	10,000	16×35.5	0.38	2,710	ESMQ160E□□103MLP1S	4.7	5×11	0.08	45	ESMQ101E□□4R7ME11D	
	15,000	18×40	0.48	3,100	ESMQ160E□□153MM40S	10	5×11	0.08	70	ESMQ101E□□100ME11D	
	22,000	22×40	0.62	3,800	ESMQ160E□□223MP40S	22	6.3×11	0.08	130	ESMQ101E□□220MF11D	
	100	5×11	0.16	180	ESMQ250E□□101ME11D	33	8×11.5	0.08	180	ESMQ101E□□330MHB5D	
	220	6.3×11	0.16	280	ESMQ250E□□221MF11D	47	8×11.5	0.08	200	ESMQ101E□□470MHB5D	
	330	8×11.5	0.16	440	ESMQ250E□□331MHB5D	68	10×12.5	0.08	270	ESMQ101E□□680MJC5S	
	470	10×12.5	0.16	550	ESMQ250E□□471MJC5S	100	10×16	0.08	340	ESMQ101E□□101MJ16S	
	1,000	10×16	0.16	860	ESMQ250E□□102MJ16S	220	12.5×20	0.08	550	ESMQ101E□□221MK20S	
	2,200	12.5×25	0.18	1,550	ESMQ250E□□222MK25S	330	12.5×25	0.08	760	ESMQ101E□□331MK25S	
	3,300	16×25	0.20	1,980	ESMQ250E□□332ML25S	470	16×25	0.08	1,000	ESMQ101E□□471ML25S	
35	4,700	16×25	0.22	2,200	ESMQ250E□□472ML25S	1,000	18×35.5	0.08	1,350	ESMQ101E□□102MMP1S	
	6,800	16×35.5	0.26	2,600	ESMQ250E□□682MLP1S	2,200	22×50	0.08	2,400	ESMQ101E□□222MP50S	
	10,000	18×40	0.34	2,800	ESMQ250E□□103MM40S	10	8×11.5	0.20	80	ESMQ161E□□100MHB5D	
	15,000	22×50	0.44	3,800	ESMQ250E□□153MP50S	22	10×12.5	0.20	130	ESMQ161E□□220MJC5S	
	47	5×11	0.14	130	ESMQ350E□□470ME11D	33	10×16	0.20	180	ESMQ161E□□330MJ16S	
	68	6.3×11	0.14	160	ESMQ350E□□680MF11D	47	10×20	0.20	210	ESMQ161E□□470MJ20S	
	100	6.3×11	0.14	210	ESMQ350E□□101MF11D	68	12.5×20	0.20	350	ESMQ161E□□680MK20S	
	220	8×11.5	0.14	385	ESMQ350E□□221MHB5D	100	12.5×25	0.20	430	ESMQ161E□□101MK25S	
	330	10×12.5	0.14	490	ESMQ350E□□331MJC5S	220	16×31.5	0.20	760	ESMQ161E□□221MLN3S	
	470	10×16	0.14	650	ESMQ350E□□471MJ16S	330	18×35.5	0.20	995	ESMQ161E□□331MMP1S	
50	1,000	12.5×20	0.14	1,150	ESMQ350E□□102MK20S	470	18×40	0.20	1,200	ESMQ161E□□471MM40S	
	2,200	16×25	0.16	1,800	ESMQ350E□□222ML25S	1.0	6.3×11	0.20	22	ESMQ201E□□1R0MF11D	
	3,300	16×31.5	0.18	2,100	ESMQ350E□□332MLN3S	2.2	6.3×11	0.20	33	ESMQ201E□□2R2MF11D	
	4,700	16×35.5	0.20	2,500	ESMQ350E□□472MLP1S	3.3	6.3×11	0.20	40	ESMQ201E□□3R3MF11D	
	6,800	18×40	0.24	2,800	ESMQ350E□□682MM40S	4.7	6.3×11	0.20	50	ESMQ201E□□4R7MF11D	
	10,000	22×50	0.32	3,700	ESMQ350E□□103MP50S	10	8×11.5	0.20	80	ESMQ201E□□100MHB5D	
	0.10	5×11	0.12	1.3	ESMQ500E□□R10ME11D	22	10×16	0.20	150	ESMQ201E□□220MJ16S	
	0.22	5×11	0.12	2.9	ESMQ500E□□R22ME11D	33	10×20	0.20	205	ESMQ201E□□330MJ20S	
	0.33	5×11	0.12	4.3	ESMQ500E□□R33ME11D	47	12.5×20	0.20	270	ESMQ201E□□470MK20S	
	0.47	5×11	0.12	6.2	ESMQ500E□□R47ME11D	68	12.5×25	0.20	350	ESMQ201E□□680MK25S	
1.0	5×11	0.12	17	ESMQ500E□□1R0ME11D	100	16×25	0.20	475	ESMQ201E□□101ML25S		
2.2	5×11	0.12	28	ESMQ500E□□2R2ME11D	220	16×35.5	0.20	700	ESMQ201E□□221MLP1S		
3.3	5×11	0.12	35	ESMQ500E□□3R3ME11D	330	18×40	0.20	950	ESMQ201E□□331MM40S		
4.7	5×11	0.12	41	ESMQ500E□□4R7ME11D	3.3	6.3×11	0.20	40	ESMQ251E□□3R3MF11D		
10	5×11	0.12	60	ESMQ500E□□100ME11D	4.7	6.3×11	0.20	50	ESMQ251E□□4R7MF11D		
22	5×11	0.12	95	ESMQ500E□□220ME11D	10	10×12.5	0.20	100	ESMQ251E□□100MJC5S		
33	5×11	0.12	125	ESMQ500E□□330ME11D	22	10×20	0.20	170	ESMQ251E□□220MJ20S		

□ : Lead forming / Taping code

## ◆STANDARD RATINGS

WV (Vdc)	Cap (μF)	Case size φD×L(mm)	tanδ	Rated ripple current (mA <sub>rms</sub> /85°C,120Hz)	Part No.	WV (Vdc)	Cap (μF)	Case size φD×L(mm)	tanδ	Rated ripple current (mA <sub>rms</sub> /85°C,120Hz)	Part No.	
250	33	10×20	0.20	200	ESMQ251E□□330MJ20S	400	3.3	8×11.5	0.24	48	ESMQ401E□□3R3MHB5D	
	47	12.5×20	0.20	270	ESMQ251E□□470MK20S		4.7	10×12.5	0.24	60	ESMQ401E□□4R7MJC5S	
	68	16×25	0.20	380	ESMQ251E□□680ML25S		10	10×16	0.24	90	ESMQ401E□□100MJ16S	
	100	16×25	0.20	440	ESMQ251E□□101ML25S		22	12.5×25	0.24	205	ESMQ401E□□220MK25S	
	220	18×35.5	0.20	680	ESMQ251E□□221MMP1S		33	16×25	0.24	275	ESMQ401E□□330ML25S	
350	2.2	6.3×11	0.24	30	ESMQ351E□□2R2MF11D	400	47	16×25	0.24	280	ESMQ401E□□470ML25S	
	3.3	8×11.5	0.24	46	ESMQ351E□□3R3MHB5D		68	16×31.5	0.24	340	ESMQ401E□□680MLN3S	
	4.7	8×11.5	0.24	55	ESMQ351E□□4R7MHB5D		100	18×35.5	0.24	440	ESMQ401E□□101MMP1S	
	10	10×12.5	0.24	90	ESMQ351E□□100MJC5S		450	2.2	8×11.5	0.24	28	ESMQ451E□□2R2MHB5D
	22	12.5×20	0.24	185	ESMQ351E□□220MK20S			3.3	10×12.5	0.24	40	ESMQ451E□□3R3MJC5S
	33	12.5×25	0.24	240	ESMQ351E□□330MK25S	4.7		10×12.5	0.24	46	ESMQ451E□□4R7MJC5S	
	47	16×25	0.24	325	ESMQ351E□□470ML25S	10		10×20	0.24	80	ESMQ451E□□100MJ20S	
	68	16×25	0.24	400	ESMQ351E□□680ML25S	22	12.5×25	0.24	140	ESMQ451E□□220MK25S		
	100	18×31.5	0.24	530	ESMQ351E□□101MMN3S	33	16×25	0.24	180	ESMQ451E□□330ML25S		
400	0.47	6.3×11	0.24	12	ESMQ401E□□R47MF11D	47	16×31.5	0.24	220	ESMQ451E□□470MLN3S		
	1.0	6.3×11	0.24	22	ESMQ401E□□1R0MF11D	68	18×35.5	0.24	260	ESMQ451E□□680MMP1S		
	2.2	8×11.5	0.24	38	ESMQ401E□□2R2MHB5D	100	18×40	0.24	280	ESMQ451E□□101MM40S		

□□ : Lead forming / Taping code

## ◆RATED RIPPLE CURRENT MULTIPLIERS

### ●Frequency Multipliers

(φ5 to φ18)

Capacitance (μF)	Frequency (Hz)					
	50	120	300	1k	10k	100k
0.1 to 4.7	0.65	1.00	1.35	1.75	2.30	2.50
10 to 68	0.75	1.00	1.25	1.50	1.75	1.80
100 to 1,000	0.80	1.00	1.15	1.30	1.40	1.50
2,200 to	0.85	1.00	1.03	1.05	1.08	1.08

(φ20 to φ22)

Rated Voltage (V <sub>r</sub> )	Frequency (Hz)					
	50	120	300	1k	10k	100k
6.3 to 50	0.95	1.00	1.03	1.05	1.08	1.08
63 to 100	0.92	1.00	1.07	1.13	1.19	1.20

The endurance of capacitors is shorted with internal heating produced by ripple current at the rate of halving the lifetime with every 5°C rise. When long life performance is required in actual use, the rms ripple current has to be reduced.

# KMQ Series

- Downsized from current standard KMG series
- Solvent-proof type except 160 to 450V<sub>dc</sub>  
(see PRECAUTIONS AND GUIDELINES)
- RoHS Compliant



↑ Downsized  
KMG



## ◆ SPECIFICATIONS

Items	Characteristics													
Category Temperature Range	-55 to +105°C(6.3 to 100V <sub>dc</sub> ) -40 to +105°C(160 to 400V <sub>dc</sub> ) -25 to +105°C(450V <sub>dc</sub> )													
Rated Voltage Range	6.3 to 450V <sub>dc</sub>													
Capacitance Tolerance	±20% (M) (at 20°C, 120Hz)													
Leakage Current	6.3 to 100V <sub>dc</sub>													
	≤φ18	I=0.03CV or 4μA, whichever is greater.										160 to 450V <sub>dc</sub>		
		(at 20°C after 1 minute)										CV \ Time After 1 minute		
≥φ20	I=0.03CV max.										(at 20°C after 3 minutes)			
Dissipation Factor (tanδ)	Where, I : Max. leakage current (μA), C : Nominal capacitance (μF), V : Rated voltage (V)													
	Rated voltage (V <sub>dc</sub> )	6.3V	10V	16V	25V	35V	50V	63V	100V	160 to 250V	350 to 400V	450V		
	tanδ (Max.)	0.28	0.24	0.20	0.16	0.14	0.12	0.10	0.08	0.20	0.24	0.24		
Low Temperature Characteristics (Max. Impedance Ratio)	When nominal capacitance exceeds 1,000μF, add 0.02 to the value above for each 1,000μF increase. (at 20°C, 120Hz)													
	Rated voltage (V <sub>dc</sub> )	6.3V	10V	16V	25V	35V	50V	63 to 100V	160 to 200V	250V	350V	400V	450V	
	Z(-25°C)/Z(+20°C)	≤φ8	5	4	3	2	2	2	2	3	3	4	4	6
	Z(-40°C)/Z(+20°C)	≤φ8	10	8	6	4	3	3	3	8	10	8	8	—
Endurance	The following specifications shall be satisfied when the capacitors are restored to 20°C after subjected to DC voltage with the rated ripple current is applied for 1,000 hours (2,000 hours for φ10 and more at 105°C).													
	Capacitance change	≤±20% of the initial value												
	D.F. (tanδ)	≤200% of the initial specified value												
Shelf Life	The following specifications shall be satisfied when the capacitors are restored to 20°C after exposing them for 1,000 hours at 105°C without voltage applied.													
	Rated voltage	6.3 to 100V <sub>dc</sub>						160 to 450V <sub>dc</sub>						
	Capacitance change	≤±20% of the initial value						≤±20% of the initial value						
	D.F. (tanδ)	≤200% of the initial specified value						≤200% of the initial specified value						
	Leakage current	≤The initial specified value						≤500% of the initial specified value						

## ◆ DIMENSIONS [mm]

- Terminal Code : E

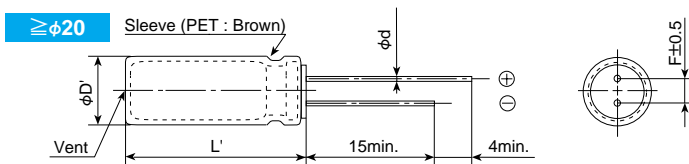
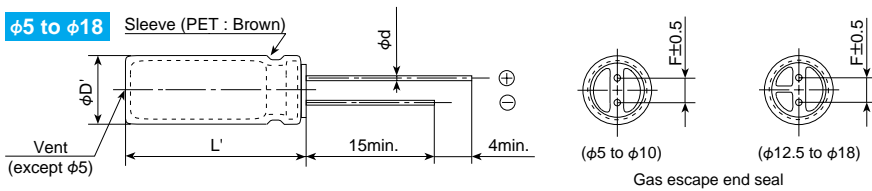

φD	5	6.3	8	10	12.5	16	18	20	22
φd	0.5	0.5	0.6	0.6	0.6	0.8	0.8	1.0	1.0
F	2.0	2.5	3.5	5.0	5.0	7.5	7.5	10.0	10.0
φD'	φD+0.5max.							φD+0.5max.	
L'	L+1.5max.							L+2.0max.	

## ◆ PART NUMBERING SYSTEM

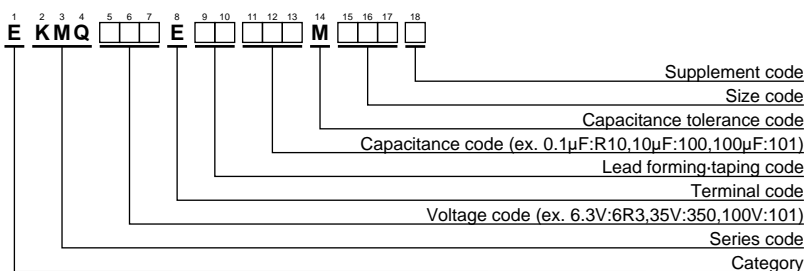

Please refer to "A guide to global code (radial lead type)"

◆STANDARD RATINGS

□ is non solvent-proof.

WV (Vdc)	Cap (μF)	Case size φD×L(mm)	tanδ	Rated ripple current (mArms/105°C,120Hz)	Part No.	WV (Vdc)	Cap (μF)	Case size φD×L(mm)	tanδ	Rated ripple current (mArms/105°C,120Hz)	Part No.
6.3	1,000	8×11.5	0.28	390	EKMQR3E□□102MHB5D	50	47	6.3×11	0.12	115	EKMQR50E□□470MF11D
	2,200	10×16	0.30	635	EKMQR3E□□222MJ16S		68	6.3×11	0.12	150	EKMQR50E□□680MF11D
	3,300	10×20	0.32	840	EKMQR3E□□332MJ20S		100	8×11.5	0.12	190	EKMQR50E□□101MHB5D
	4,700	12.5×20	0.34	1,090	EKMQR3E□□472MK20S		220	10×12.5	0.12	300	EKMQR50E□□221MJC5S
	6,800	12.5×25	0.38	1,350	EKMQR3E□□682MK25S		330	10×16	0.12	410	EKMQR50E□□331MJ16S
	10,000	16×25	0.46	1,650	EKMQR3E□□103ML25S		470	10×20	0.12	540	EKMQR50E□□471MJ20S
	15,000	16×31.5	0.56	1,820	EKMQR3E□□153MLN3S		1,000	12.5×25	0.12	950	EKMQR50E□□102MK25S
	22,000	18×35.5	0.70	2,280	EKMQR3E□□223MMP1S		2,200	16×31.5	0.14	1,410	EKMQR50E□□222MLN3S
	33,000	20×40	0.92	2,500	EKMQR3E□□333MN40S		3,300	18×35.5	0.16	1,770	EKMQR50E□□332MMP1S
	47,000	22×50	1.20	2,780	EKMQR3E□□473MP50S		4,700	20×40	0.18	2,100	EKMQR50E□□472MN40S
10	220	5×11	0.24	155	EKMQR100E□□221ME11D	6,800	22×50	0.22	2,500	EKMQR50E□□682MP50S	
	330	6.3×11	0.24	210	EKMQR100E□□331MF11D	63	22	5×11	0.10	71	EKMQR630E□□220ME11D
	470	6.3×11	0.24	250	EKMQR100E□□471MF11D		33	6.3×11	0.10	100	EKMQR630E□□330MF11D
	1,000	10×12.5	0.24	460	EKMQR100E□□102MJC5S		47	6.3×11	0.10	120	EKMQR630E□□470MF11D
	2,200	10×16	0.26	705	EKMQR100E□□222MJ16S		68	8×11.5	0.10	155	EKMQR630E□□680MHB5D
	3,300	12.5×20	0.28	1,000	EKMQR100E□□332MK20S		100	8×11.5	0.10	200	EKMQR630E□□101MHB5D
	4,700	12.5×25	0.30	1,260	EKMQR100E□□472MK25S		220	10×16	0.10	335	EKMQR630E□□221MJ16S
	6,800	16×25	0.34	1,570	EKMQR100E□□682ML25S		330	10×20	0.10	510	EKMQR630E□□331MJ20S
	10,000	16×31.5	0.42	1,820	EKMQR100E□□103MLN3S		470	12.5×20	0.10	640	EKMQR630E□□471MK20S
	15,000	16×35.5	0.52	2,050	EKMQR100E□□153MLP1S		1,000	16×25	0.10	930	EKMQR630E□□102ML25S
22,000	18×40	0.66	2,420	EKMQR100E□□223MMP40S	2,200		18×35.5	0.12	1,650	EKMQR630E□□222MMP1S	
16	33,000	22×50	0.88	3,210	EKMQR100E□□333MP50S	3,300	20×40	0.14	1,950	EKMQR630E□□332MN40S	
	220	6.3×11	0.20	190	EKMQR160E□□221MF11D	4,700	22×50	0.16	2,450	EKMQR630E□□472MP50S	
	330	6.3×11	0.20	225	EKMQR160E□□331MF11D	100	0.10	5×11	0.08	1.5	EKMQR101E□□R10ME11D
	470	8×11.5	0.20	315	EKMQR160E□□471MHB5D		0.22	5×11	0.08	3.4	EKMQR101E□□R22ME11D
	1,000	10×12.5	0.20	500	EKMQR160E□□102MJC5S		0.33	5×11	0.08	5.0	EKMQR101E□□R33ME11D
	2,200	10×20	0.22	710	EKMQR160E□□222MJ20S		0.47	5×11	0.08	7.1	EKMQR101E□□R47ME11D
	3,300	12.5×25	0.24	1,170	EKMQR160E□□332MK25S		1.0	5×11	0.08	15	EKMQR101E□□R10ME11D
	4,700	16×25	0.26	1,500	EKMQR160E□□472ML25S		2.2	5×11	0.08	21	EKMQR101E□□R22ME11D
	6,800	16×25	0.30	1,600	EKMQR160E□□682ML25S		3.3	5×11	0.08	29	EKMQR101E□□R33ME11D
	10,000	16×35.5	0.38	1,930	EKMQR160E□□103MLP1S		4.7	5×11	0.08	32	EKMQR101E□□R47ME11D
15,000	18×40	0.48	2,210	EKMQR160E□□153MM40S	10		5×11	0.08	50	EKMQR101E□□R100ME11D	
22,000	22×40	0.62	2,710	EKMQR160E□□223MP40S	22		6.3×11	0.08	93	EKMQR101E□□R220MF11D	
25	100	5×11	0.16	125	EKMQR250E□□101ME11D	33	8×11.5	0.08	130	EKMQR101E□□R330MHB5D	
	220	6.3×11	0.16	200	EKMQR250E□□221MF11D	47	8×11.5	0.08	140	EKMQR101E□□R470MHB5D	
	330	8×11.5	0.16	310	EKMQR250E□□331MHB5D	68	10×12.5	0.08	190	EKMQR101E□□R680MJC5S	
	470	10×12.5	0.16	380	EKMQR250E□□471MJC5S	100	10×16	0.08	240	EKMQR101E□□R101MJ16S	
	1,000	10×16	0.16	610	EKMQR250E□□102MJ16S	220	12.5×20	0.08	390	EKMQR101E□□R221MK20S	
	2,200	12.5×25	0.18	1,090	EKMQR250E□□222MK25S	330	12.5×25	0.08	540	EKMQR101E□□R331MK25S	
	3,300	16×25	0.20	1,400	EKMQR250E□□332ML25S	470	16×25	0.08	715	EKMQR101E□□R471ML25S	
	4,700	16×25	0.22	1,570	EKMQR250E□□472ML25S	1,000	18×35.5	0.08	960	EKMQR101E□□R102MMP1S	
	6,800	16×35.5	0.26	1,850	EKMQR250E□□682MLP1S	2,200	22×50	0.10	1,750	EKMQR101E□□R222MP50S	
	10,000	18×40	0.34	2,000	EKMQR250E□□103MM40S	160	10	8×11.5	0.20	41	EKMQR161E□□R100MHB5D
15,000	22×50	0.44	2,750	EKMQR250E□□153MP50S	22		10×12.5	0.20	92	EKMQR161E□□R220MJC5S	
47	5×11	0.14	93	EKMQR350E□□R470ME11D	33		10×16	0.20	125	EKMQR161E□□R330MJ16S	
68	6.3×11	0.14	110	EKMQR350E□□R680MF11D	47		10×20	0.20	150	EKMQR161E□□R470MJ20S	
100	6.3×11	0.14	150	EKMQR350E□□R101MF11D	68		12.5×20	0.20	250	EKMQR161E□□R680MK20S	
220	8×11.5	0.14	270	EKMQR350E□□R221MHB5D	100		12.5×25	0.20	310	EKMQR161E□□R101MK25S	
330	10×12.5	0.14	350	EKMQR350E□□R331MJC5S	220		16×31.5	0.20	540	EKMQR161E□□R221MLN3S	
470	10×16	0.14	460	EKMQR350E□□R471MJ16S	330		18×35.5	0.20	705	EKMQR161E□□R331MMP1S	
1,000	12.5×20	0.14	810	EKMQR350E□□R102MK20S	470		18×40	0.20	855	EKMQR161E□□R471MM40S	
2,200	16×25	0.16	1,260	EKMQR350E□□R222ML25S	200		1.0	6.3×11	0.20	16	EKMQR201E□□R10R0MF11D
3,300	16×31.5	0.18	1,500	EKMQR350E□□R332MLN3S		2.2	6.3×11	0.20	25	EKMQR201E□□R22R2MF11D	
4,700	16×35.5	0.20	1,780	EKMQR350E□□R472MLP1S		3.3	6.3×11	0.20	30	EKMQR201E□□R33R3MF11D	
6,800	18×40	0.24	2,000	EKMQR350E□□R682MM40S		4.7	6.3×11	0.20	35	EKMQR201E□□R47R7MF11D	
10,000	22×50	0.32	2,650	EKMQR350E□□R103MP50S		10	8×11.5	0.20	57	EKMQR201E□□R100MHB5D	
47	5×11	0.12	13	EKMQR500E□□R10R0ME11D		22	10×16	0.20	105	EKMQR201E□□R220MJ16S	
2.2	5×11	0.12	20	EKMQR500E□□R22R2ME11D		33	10×20	0.20	140	EKMQR201E□□R330MJ20S	
3.3	5×11	0.12	25	EKMQR500E□□R33R3ME11D		47	12.5×20	0.20	195	EKMQR201E□□R470MK20S	
4.7	5×11	0.12	30	EKMQR500E□□R47R7ME11D		68	12.5×25	0.20	250	EKMQR201E□□R680MK25S	
10	5×11	0.12	46	EKMQR500E□□R100ME11D		100	16×25	0.20	335	EKMQR201E□□R101ML25S	
22	5×11	0.12	68	EKMQR500E□□R220ME11D	220	16×35.5	0.20	500	EKMQR201E□□R221MLP1S		
33	5×11	0.12	90	EKMQR500E□□R330ME11D	330	18×40	0.20	675	EKMQR201E□□R331MM40S		
50	3.3	6.3×11	0.20	28	EKMQR251E□□R3R3MF11D	250	4.7	6.3×11	0.20	35	EKMQR251E□□R4R7MF11D
	4.7	6.3×11	0.20	35	EKMQR251E□□R4R7MF11D		10	10×12.5	0.20	71	EKMQR251E□□R100MJC5S
	10	10×12.5	0.20	71	EKMQR251E□□R100MJC5S		22	10×20	0.20	105	EKMQR251E□□R220MJ20S
	22	10×20	0.20	105	EKMQR251E□□R220MJ20S						

□ : Lead forming / Taping code



◆STANDARD RATINGS

□ is non solvent-proof.

WV (Vdc)	Cap (μF)	Case size φD×L(mm)	tanδ	Rated ripple current (mA <sub>rms</sub> /105°C,120Hz)	Part No.	WV (Vdc)	Cap (μF)	Case size φD×L(mm)	tanδ	Rated ripple current (mA <sub>rms</sub> /105°C,120Hz)	Part No.	
250	33	10×20	0.20	140	EKMQ251E□□330MJ20S	400	3.3	8×11.5	0.24	34	EKMQ401E□□3R3MHB5D	
	47	12.5×20	0.20	190	EKMQ251E□□470MK20S		4.7	10×12.5	0.24	42	EKMQ401E□□4R7MJC5S	
	68	16×25	0.20	270	EKMQ251E□□680ML25S		10	10×16	0.24	64	EKMQ401E□□100MJ16S	
	100	16×25	0.20	310	EKMQ251E□□101ML25S		22	12.5×25	0.24	145	EKMQ401E□□220MK25S	
	220	18×35.5	0.20	485	EKMQ251E□□221MMP1S		33	16×25	0.24	195	EKMQ401E□□330ML25S	
350	2.2	6.3×11	0.24	21	EKMQ351E□□2R2MF11D		47	16×25	0.24	200	EKMQ401E□□470ML25S	
	3.3	8×11.5	0.24	30	EKMQ351E□□3R3MHB5D		68	16×31.5	0.24	240	EKMQ401E□□680MLN3S	
	4.7	8×11.5	0.24	39	EKMQ351E□□4R7MHB5D		100	18×35.5	0.24	310	EKMQ401E□□101MMP1S	
	10	10×12.5	0.24	64	EKMQ351E□□100MJC5S		450	2.2	8×11.5	0.24	20	EKMQ451E□□2R2MHB5D
	22	12.5×20	0.24	130	EKMQ351E□□220MK20S			3.3	10×12.5	0.24	28	EKMQ451E□□3R3MJC5S
	33	12.5×25	0.24	170	EKMQ351E□□330MK25S	4.7		10×12.5	0.24	32	EKMQ451E□□4R7MJC5S	
	47	16×25	0.24	230	EKMQ351E□□470ML25S	10		10×20	0.24	56	EKMQ451E□□100MJ20S	
	68	16×25	0.24	285	EKMQ351E□□680ML25S	22		12.5×25	0.24	100	EKMQ451E□□220MK25S	
100	18×31.5	0.24	375	EKMQ351E□□101MMN3S	33	16×25		0.24	125	EKMQ451E□□330ML25S		
400	0.47	6.3×11	0.24	8.5	EKMQ401E□□R47MF11D	47		16×31.5	0.24	155	EKMQ451E□□470MLN3S	
	1.0	6.3×11	0.24	15	EKMQ401E□□1R0MF11D	68		18×35.5	0.24	185	EKMQ451E□□680MMP1S	
	2.2	8×11.5	0.24	27	EKMQ401E□□2R2MHB5D	100	18×40	0.24	200	EKMQ451E□□101MM40S		

□ : Lead forming / Taping code

◆RATED RIPPLE CURRENT MULTIPLIERS

●Frequency Multipliers

(φ5 to φ18)

Capacitance (μF)	Frequency (Hz)					
	50	120	300	1k	10k	100k
0.1 to 4.7	0.65	1.00	1.35	1.75	2.30	2.50
10 to 68	0.75	1.00	1.25	1.50	1.75	1.80
100 to 1,000	0.80	1.00	1.15	1.30	1.40	1.50
2,200 to	0.85	1.00	1.03	1.05	1.08	1.08

(φ20 to φ22)

Rated Voltage (V <sub>dc</sub> )	Frequency (Hz)					
	50	120	300	1k	10k	100k
6.3 to 50	0.95	1.00	1.03	1.05	1.08	1.08
63 to 100	0.92	1.00	1.07	1.13	1.19	1.20

The endurance of capacitors is shorted with internal heating produced by ripple current at the rate of halving the lifetime with every 5°C rise. When long life performance is required in actual use, the rms ripple current has to be reduced.

# SMG Series

- Downsized from SME series
- Endurance : 2,000 hours at 85°C
- Solvent-proof type except 315 to 450V<sub>dc</sub>  
(see PRECAUTIONS AND GUIDELINES)
- RoHS Compliant

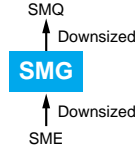

## ◆ SPECIFICATIONS

Items	Characteristics													
Category	-40 to +85°C(6.3 to 400V <sub>dc</sub> ) -25 to +85°C(450V <sub>dc</sub> )													
Temperature Range														
Rated Voltage Range	6.3 to 450V <sub>dc</sub>													
Capacitance Tolerance	±20% (M) (at 20°C, 120Hz)													
Leakage Current	≤φ18	6.3 to 100V <sub>dc</sub>						160 to 450V <sub>dc</sub>						
		I=0.03CV or 4μA, whichever is greater. (at 20°C after 1 minute)												
			CV ≤ 1,000			CV > 1,000			Time After 1 minute			Time After 5 minutes		
			I=0.1CV+40 max.			I=0.04CV+100 max.			I=0.03CV+15 max.			I=0.02CV+25 max.		
≥φ20	I=0.03CV (at 20°C after 3 minutes)													
Where, I : Max. leakage current (μA), C : Nominal capacitance (μF), V : Rated voltage (V)														
Dissipation Factor (tanδ)	Rated voltage (V <sub>dc</sub> )		6.3V	10V	16V	25V	35V	50V	63V	100V	160 to 250V	315 to 400V	450V	
	tanδ (Max.)	≤φ18	0.34	0.24	0.20	0.16	0.14	0.12	0.09	0.08	0.20	0.24	0.24	
		≥φ20	0.28	0.24	0.20	0.16	0.14	0.12	0.09	0.08	0.15	0.15	0.20	
When nominal capacitance exceeds 1,000μF, add 0.02 to the value above for each 1,000μF increase. (at 20°C, 120Hz)														
Low Temperature Characteristics (Max. Impedance Ratio)	Rated voltage (V <sub>dc</sub> )		6.3V	10V	16V	25V	35V	50V	63V	100V	160 to 250V	315 to 400V	450V	
	Z(-25°C)/Z(+20°C)	≤φ18	5	4	3	2	2	2	2	2	3	6	6	
		≥φ20	5	4	3	2	2	2	2	2	4	6	6	
Z(-40°C)/Z(+20°C)	≤φ18	12	10	8	5	4	3	3	3	4	6	-		
(at 120Hz)														
Endurance	The following specifications shall be satisfied when the capacitors are restored to 20°C after the rated voltage is applied for 2,000 hours at 85°C.													
	Capacitance change	≤±20% of the initial value												
	D.F. (tanδ)	≤200% of the initial specified value												
	Leakage current	≤The initial specified value												
Shelf Life	The following specifications shall be satisfied when the capacitors are restored to 20°C after exposing them for 1,000 hours at 85°C without voltage applied.													
	Rated voltage	6.3 to 100V <sub>dc</sub>						160 to 450V <sub>dc</sub>						
	Capacitance change	≤±20% of the initial value						≤±20% of the initial value						
	D.F. (tanδ)	≤200% of the initial specified value						≤200% of the initial specified value						
	Leakage current	≤The initial specified value						≤500% of the initial specified value						

## ◆ DIMENSIONS [mm]

- Terminal Code : E

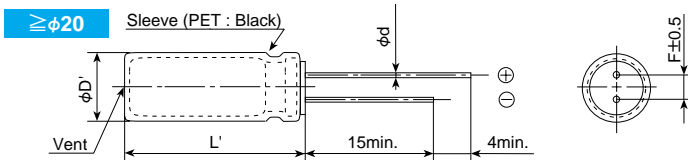
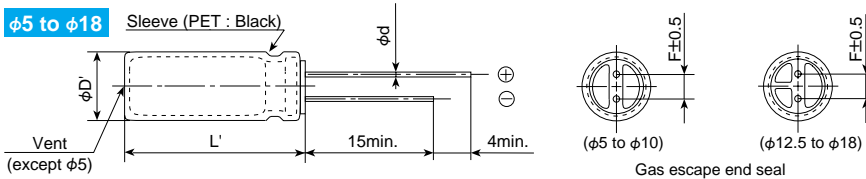

φD	5	6.3	8	10	12.5	16	18	20	22	25.4	
φd	0.5	0.5	0.6	0.6	0.6	0.8	0.8	1.0	1.0	1.0	
F	2.0	2.5	3.5	5.0	5.0	7.5	7.5	10.0	10.0	12.5	
φD'	φD+0.5max.							φD+0.5max.			
L'	L+1.5max.							L+2.0max.			

## ◆ PART NUMBERING SYSTEM

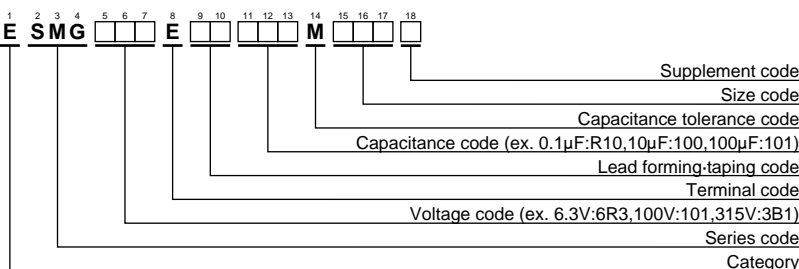

Please refer to "A guide to global code (radial lead type)"

◆STANDARD RATINGS

WV (Vdc)	Cap (μF)	Case size φDXL(mm)	tanδ	Rated ripple current (mA rms/85°C, 120Hz)	Part No.	WV (Vdc)	Cap (μF)	Case size φDXL(mm)	tanδ	Rated ripple current (mA rms/85°C, 120Hz)	Part No.
6.3	33	5X11	0.34	77	ESMG6R3E□□330ME11D	25	4.7	5X11	0.16	36	ESMG250E□□4R7ME11D
	47	5X11	0.34	92	ESMG6R3E□□470ME11D		10	5X11	0.16	53	ESMG250E□□100ME11D
	100	5X11	0.34	134	ESMG6R3E□□101ME11D		22	5X11	0.16	78	ESMG250E□□220ME11D
	220	5X11	0.34	200	ESMG6R3E□□221ME11D		33	5X11	0.16	96	ESMG250E□□330ME11D
	330	6.3X11	0.34	270	ESMG6R3E□□331MF11D		47	5X11	0.16	115	ESMG250E□□470ME11D
	470	6.3X11	0.34	320	ESMG6R3E□□471MF11D		100	6.3X11	0.16	190	ESMG250E□□101MF11D
	1,000	8X11.5	0.34	540	ESMG6R3E□□102MHB5D		220	8X11.5	0.16	330	ESMG250E□□221MHB5D
	2,200	10X20	0.36	1,000	ESMG6R3E□□222MJ20S		330	8X11.5	0.16	440	ESMG250E□□331MHB5D
	3,300	10X20	0.38	1,185	ESMG6R3E□□332MJ20S		470	10X12.5	0.16	545	ESMG250E□□471MJ20S
	4,700	12.5X20	0.40	1,545	ESMG6R3E□□472ML20S		1,000	10X20	0.16	955	ESMG250E□□102MJ20S
	6,800	12.5X25	0.44	1,915	ESMG6R3E□□682MK25S		2,200	12.5X25	0.18	1,540	ESMG250E□□222MK25S
	10,000	16X25	0.52	2,330	ESMG6R3E□□103ML25S		3,300	16X25	0.20	1,975	ESMG250E□□332ML25S
	10,000	20X25	0.46	2,310	ESMG6R3E□□103MN25S		3,300	20X20	0.20	1,850	ESMG250E□□332MN20S
	15,000	16X35.5	0.62	2,845	ESMG6R3E□□153MLP1S		4,700	16X31.5	0.22	2,420	ESMG250E□□472MLN3S
	15,000	20X30	0.56	2,660	ESMG6R3E□□153MN30S		4,700	20X25	0.22	2,420	ESMG250E□□472MN25S
	18,000	20X35	0.62	2,890	ESMG6R3E□□183MN35S		5,600	20X30	0.24	2,430	ESMG250E□□562MN30S
	18,000	22X30	0.62	2,860	ESMG6R3E□□183MP30S		6,800	18X35.5	0.26	2,880	ESMG250E□□682MMP1S
	22,000	18X40	0.76	3,320	ESMG6R3E□□223MM40S		6,800	20X35	0.26	2,680	ESMG250E□□682MN35S
	22,000	20X40	0.70	3,130	ESMG6R3E□□223MN40S		6,800	22X30	0.26	2,510	ESMG250E□□682MP30S
	22,000	22X35	0.70	3,130	ESMG6R3E□□223MP35S		8,200	20X40	0.30	2,810	ESMG250E□□822MN40S
27,000	22X40	0.80	3,280	ESMG6R3E□□273MP40S	8,200	22X35	0.30	2,810	ESMG250E□□822MP35S		
39,000	25.4X40	1.04	3,560	ESMG6R3E□□393MQ40S	10,000	22X40	0.34	3,240	ESMG250E□□103MP40S		
10	22	5X11	0.24	66	ESMG100E□□220ME11D	12,000	22X40	0.38	3,240	ESMG250E□□123MP40S	
	33	5X11	0.24	83	ESMG100E□□330ME11D	15,000	25.4X40	0.44	3,610	ESMG250E□□153MQ40S	
	47	5X11	0.24	100	ESMG100E□□470ME11D	35	4.7	5X11	0.14	41	ESMG350E□□4R7ME11D
	100	5X11	0.24	146	ESMG100E□□101ME11D		10	5X11	0.14	59	ESMG350E□□100ME11D
	220	5X11	0.24	240	ESMG100E□□221ME11D		22	5X11	0.14	88	ESMG350E□□220ME11D
	330	6.3X11	0.24	290	ESMG100E□□331MF11D		33	5X11	0.14	108	ESMG350E□□330ME11D
	470	6.3X11	0.24	350	ESMG100E□□471MF11D		47	5X11	0.14	130	ESMG350E□□470ME11D
	1,000	10X12.5	0.24	650	ESMG100E□□102MJ20S		100	6.3X11	0.14	210	ESMG350E□□100ME11D
	2,200	10X20	0.26	1,070	ESMG100E□□222MJ20S		220	8X11.5	0.14	385	ESMG350E□□221MHB5D
	3,300	12.5X20	0.28	1,420	ESMG100E□□332MK20S		330	10X12.5	0.14	490	ESMG350E□□331MJ20S
	4,700	12.5X25	0.30	1,780	ESMG100E□□472MK25S		470	10X16	0.14	645	ESMG350E□□471MJ16S
	6,800	16X25	0.34	2,220	ESMG100E□□682ML25S		1,000	12.5X20	0.14	1,145	ESMG350E□□102MK20S
	6,800	20X20	0.34	2,080	ESMG100E□□682MN20S		2,200	16X25	0.16	1,785	ESMG350E□□222ML25S
	10,000	16X35.5	0.42	2,670	ESMG100E□□103MLP1S		2,200	20X20	0.16	1,670	ESMG350E□□222MN20S
	10,000	20X25	0.42	2,410	ESMG100E□□103MN25S		3,300	16X35.5	0.18	2,275	ESMG350E□□332MLP1S
	12,000	20X30	0.46	2,620	ESMG100E□□123MN30S		3,300	20X25	0.18	2,050	ESMG350E□□332MN25S
	15,000	18X35.5	0.52	3,080	ESMG100E□□153MMP1S		3,900	20X30	0.18	2,310	ESMG350E□□392MN30S
	15,000	20X35	0.52	2,870	ESMG100E□□153MN35S		4,700	18X35.5	0.20	2,700	ESMG350E□□472MMP1S
	15,000	22X30	0.52	2,660	ESMG100E□□153MP30S		4,700	20X35	0.20	2,510	ESMG350E□□472MN35S
	18,000	22X35	0.58	3,050	ESMG100E□□183MP35S		4,700	22X30	0.20	2,380	ESMG350E□□472MP30S
22,000	22X40	0.66	3,480	ESMG100E□□223MP40S	5,600		20X40	0.22	2,690	ESMG350E□□562MN40S	
33,000	25.4X40	0.88	3,560	ESMG100E□□333MQ40S	5,600		22X35	0.22	2,690	ESMG350E□□562MP35S	
16	10	5X11	0.20	50	ESMG160E□□100ME11D	6,800	22X40	0.24	3,090	ESMG350E□□682MP40S	
	22	5X11	0.20	75	ESMG160E□□220ME11D	10,000	25.4X40	0.32	3,480	ESMG350E□□103MQ40S	
	33	5X11	0.20	91	ESMG160E□□330ME11D	50	0.10	5X11	0.12	1.3	ESMG500E□□R10ME11D
	47	5X11	0.20	109	ESMG160E□□470ME11D		0.22	5X11	0.12	2.9	ESMG500E□□R22ME11D
	100	5X11	0.20	160	ESMG160E□□101ME11D		0.33	5X11	0.12	4.3	ESMG500E□□R33ME11D
	220	6.3X11	0.20	260	ESMG160E□□221MF11D		0.47	5X11	0.12	6.2	ESMG500E□□R47ME11D
	330	8X11.5	0.20	370	ESMG160E□□331MHB5D		1.0	5X11	0.12	17	ESMG500E□□R10ME11D
	470	8X11.5	0.20	440	ESMG160E□□471MHB5D		2.2	5X11	0.12	28	ESMG500E□□R22ME11D
	1,000	10X16	0.20	785	ESMG160E□□102MJ16S		3.3	5X11	0.12	35	ESMG500E□□R33ME11D
	2,200	12.5X20	0.22	1,295	ESMG160E□□222MK20S		4.7	5X11	0.12	41	ESMG500E□□R47ME11D
	3,300	12.5X25	0.24	1,655	ESMG160E□□332MK25S		10	5X11	0.12	60	ESMG500E□□100ME11D
	4,700	16X25	0.26	2,090	ESMG160E□□472ML25S		22	5X11	0.12	95	ESMG500E□□220ME11D
	4,700	20X20	0.26	1,960	ESMG160E□□472MN20S		33	5X11	0.12	125	ESMG500E□□330ME11D
	6,800	16X31.5	0.30	2,520	ESMG160E□□682MLN3S		47	6.3X11	0.12	155	ESMG500E□□470MF11D
	6,800	20X25	0.30	2,330	ESMG160E□□682MN25S		100	8X11.5	0.12	260	ESMG500E□□101MHB5D
	8,200	20X30	0.34	2,500	ESMG160E□□822MN30S		220	10X12.5	0.12	430	ESMG500E□□221MJ20S
	10,000	18X35.5	0.38	2,920	ESMG160E□□103MMP1S		330	10X16	0.12	585	ESMG500E□□331MJ16S
	10,000	20X35	0.38	2,720	ESMG160E□□103MN35S		470	10X20	0.12	755	ESMG500E□□471MJ20S
	10,000	22X30	0.38	2,660	ESMG160E□□103MP30S		1,000	12.5X25	0.12	1,340	ESMG500E□□102MK25S
	12,000	20X40	0.42	2,900	ESMG160E□□123MN40S		1,500	20X20	0.12	1,570	ESMG500E□□152MN20S
12,000	22X35	0.42	2,900	ESMG160E□□123MP35S	2,200		16X35.5	0.14	2,075	ESMG500E□□222MLP1S	
15,000	22X40	0.48	3,380	ESMG160E□□153MP40S	2,200		20X25	0.14	1,880	ESMG500E□□222MN25S	
22,000	25.4X40	0.62	3,720	ESMG160E□□223MQ40S	2,700	20X30	0.14	2,150	ESMG500E□□272MN30S		

□ □ : Lead forming / Taping code



◆STANDARD RATINGS

□ is non solvent-proof.

WV (Vdc)	Cap (μF)	Case size φDXL(mm)	tanδ	Rated ripple current (mA rms/85°C, 120Hz)	Part No.	WV (Vdc)	Cap (μF)	Case size φDXL(mm)	tanδ	Rated ripple current (mA rms/85°C, 120Hz)	Part No.	
50	3,300	18X35.5	0.16	2,500	ESMG500E□□332MMP1S	200	22	10X20	0.20	170	ESMG201E□□220MJ20S	
	3,300	20X35	0.16	2,420	ESMG500E□□332MN35S		33	10X20	0.20	205	ESMG201E□□330MJ20S	
	3,300	22X30	0.16	2,420	ESMG500E□□332MP30S		47	12.5X20	0.20	270	ESMG201E□□470MK20S	
	3,900	20X40	0.16	2,590	ESMG500E□□392MN40S		100	16X25	0.20	475	ESMG201E□□101ML25S	
	3,900	22X35	0.16	2,590	ESMG500E□□392MP35S		100	20X20	0.15	460	ESMG201E□□101MN20S	
	4,700	22X40	0.18	2,960	ESMG500E□□472MP40S		180	20X25	0.15	660	ESMG201E□□181MN25S	
	6,800	25.4X40	0.22	3,360	ESMG500E□□682MQ40S		220	18X35.5	0.20	810	ESMG201E□□221MMP1S	
63	10	5X11	0.09	65	ESMG630E□□100ME11D		220	20X30	0.15	750	ESMG201E□□221MN30S	
	22	5X11	0.09	100	ESMG630E□□220ME11D		270	20X30	0.15	830	ESMG201E□□271MN30S	
	33	6.3X11	0.09	140	ESMG630E□□331MJ11D		330	20X35	0.15	1,070	ESMG201E□□331MP35S	
	47	6.3X11	0.09	170	ESMG630E□□470MF11D		330	22X30	0.15	1,070	ESMG201E□□331MP30S	
	100	10X12.5	0.09	300	ESMG630E□□101MJC5S		390	20X40	0.15	1,190	ESMG201E□□391MN40S	
	220	10X16	0.09	490	ESMG630E□□221MJ16S		390	22X30	0.15	1,160	ESMG201E□□391MP30S	
	330	10X20	0.09	710	ESMG630E□□331MJ20S		470	22X40	0.15	1,350	ESMG201E□□471MP40S	
	470	12.5X20	0.09	900	ESMG630E□□471MK20S		560	22X40	0.15	1,430	ESMG201E□□561MP40S	
	820	20X20	0.09	1,370	ESMG630E□□821MN20S		680	25.4X40	0.15	1,620	ESMG201E□□681MQ40S	
	1,000	16X25	0.09	1,300	ESMG630E□□102ML25S		250	2.2	6.3X11	0.20	32	ESMG251E□□2R2MF11D
	1,000	20X25	0.09	1,600	ESMG630E□□102MN25S			3.3	8X11.5	0.20	46	ESMG251E□□3R3MHB5D
	1,500	20X30	0.09	1,850	ESMG630E□□152MN30S			4.7	8X11.5	0.20	55	ESMG251E□□4R7MHB5D
	2,200	20X35	0.11	2,330	ESMG630E□□222MN35S			10	10X16	0.20	105	ESMG251E□□100MJ16S
2,200	22X30	0.11	2,190	ESMG630E□□222MP30S	22	10X20		0.20	170	ESMG251E□□220MJ20S		
2,700	20X40	0.11	2,640	ESMG630E□□272MN40S	33	12.5X20		0.20	230	ESMG251E□□330MK20S		
3,300	22X40	0.13	2,810	ESMG630E□□332MP40S	47	12.5X25		0.20	295	ESMG251E□□470MK25S		
3,900	25.4X40	0.13	3,100	ESMG630E□□392MQ40S	82	20X20		0.15	420	ESMG251E□□820MN20S		
100	0.10	5X11	0.08	2.1	ESMG101E□□R10ME11D	100		16X31.5	0.20	515	ESMG251E□□101MLN3S	
	0.22	5X11	0.08	4.7	ESMG101E□□R22ME11D	100		20X25	0.15	490	ESMG251E□□101MN25S	
	0.33	5X11	0.08	7.0	ESMG101E□□R33ME11D	120		20X25	0.15	530	ESMG251E□□121MN25S	
	0.47	5X11	0.08	10	ESMG101E□□R47ME11D	180		20X30	0.15	680	ESMG251E□□181MN30S	
	1.0	5X11	0.08	21	ESMG101E□□R10ME11D	220		18X40	0.20	825	ESMG251E□□221MM40S	
	2.2	5X11	0.08	30	ESMG101E□□R22ME11D	220		20X35	0.15	780	ESMG251E□□221MN35S	
	3.3	5X11	0.08	40	ESMG101E□□R33ME11D	220		22X30	0.15	820	ESMG251E□□221MP30S	
	4.7	5X11	0.08	45	ESMG101E□□R47ME11D	270		20X40	0.15	880	ESMG251E□□271MN40S	
	10	6.3X11	0.08	75	ESMG101E□□100MF11D	270		22X35	0.15	880	ESMG251E□□271MP35S	
	22	8X11.5	0.08	130	ESMG101E□□220MHB5D	330	22X40	0.15	1,060	ESMG251E□□331MP40S		
	33	8X11.5	0.08	180	ESMG101E□□330MHB5D	390	25.4X40	0.15	1,200	ESMG251E□□391MQ40S		
	47	10X12.5	0.08	230	ESMG101E□□470MJC5S	315	47	20X20	0.15	310	ESMG3B1E□□470MN20S	
	100	10X20	0.08	370	ESMG101E□□101MJ20S		68	20X25	0.15	400	ESMG3B1E□□680MN25S	
	220	12.5X25	0.08	620	ESMG101E□□221MK25S		82	20X25	0.15	440	ESMG3B1E□□820MN25S	
	330	12.5X25	0.08	760	ESMG101E□□331MK25S		100	20X30	0.15	500	ESMG3B1E□□101MN30S	
	330	20X20	0.08	870	ESMG101E□□331MN20S		120	20X30	0.15	550	ESMG3B1E□□121MN30S	
	470	16X25	0.08	1,000	ESMG101E□□471ML25S		180	20X40	0.15	720	ESMG3B1E□□181MN40S	
680	20X30	0.08	1,360	ESMG101E□□681MN30S	180		22X35	0.15	720	ESMG3B1E□□181MP35S		
820	22X30	0.08	1,540	ESMG101E□□821MP30S	220		22X40	0.15	810	ESMG3B1E□□221MP40S		
1,000	18X40	0.08	1,380	ESMG101E□□102MM40S	270		25.4X40	0.15	920	ESMG3B1E□□271MQ40S		
1,000	20X35	0.08	1,720	ESMG101E□□102MN35S	350	0.47	6.3X11	0.24	15	ESMG351E□□R47MF11D		
1,200	22X40	0.08	1,980	ESMG101E□□122MP40S		1.0	6.3X11	0.24	22	ESMG351E□□1R0MF11D		
1,800	25.4X40	0.08	2,490	ESMG101E□□182MQ40S		2.2	8X11.5	0.24	38	ESMG351E□□2R2MHB5D		
160	3.3	6.3X11	0.20	40		ESMG161E□□3R3MF11D	3.3	8X11.5	0.24	46	ESMG351E□□3R3MHB5D	
	4.7	6.3X11	0.20	48		ESMG161E□□4R7MF11D	4.7	10X12.5	0.24	65	ESMG351E□□4R7MJC5S	
	10	10X12.5	0.20	94		ESMG161E□□100MJC5S	10	10X20	0.24	115	ESMG351E□□100MJ20S	
	22	10X20	0.20	170		ESMG161E□□220MJ20S	22	12.5X20	0.24	185	ESMG351E□□220MK20S	
	33	10X20	0.20	205		ESMG161E□□330MJ20S	33	16X25	0.24	275	ESMG351E□□330ML25S	
	47	12.5X20	0.20	270		ESMG161E□□470MK20S	47	16X25	0.24	325	ESMG351E□□470ML25S	
	100	12.5X25	0.20	430		ESMG161E□□101MK25S	47	20X20	0.15	310	ESMG351E□□470MN20S	
	220	16X31.5	0.20	760	ESMG161E□□221MLN3S	68	20X25	0.15	400	ESMG351E□□680MN25S		
	220	20X25	0.15	730	ESMG161E□□221MN25S	100	18X31.5	0.24	530	ESMG351E□□101MMN3S		
	330	18X35.5	0.20	995	ESMG161E□□331MMP1S	100	20X30	0.15	500	ESMG351E□□101MN30S		
	330	20X30	0.15	920	ESMG161E□□331MN30S	120	20X35	0.15	560	ESMG351E□□121MN35S		
	390	20X35	0.15	1,160	ESMG161E□□391MN35S	220	25.4X40	0.15	890	ESMG351E□□221MQ40S		
	390	22X30	0.15	1,160	ESMG161E□□391MP30S	400	1.0	6.3X11	0.24	22	ESMG401E□□1R0MF11D	
470	20X40	0.15	1,340	ESMG161E□□471MN40S	2.2		8X11.5	0.24	38	ESMG401E□□2R2MHB5D		
470	22X35	0.15	1,340	ESMG161E□□471MP35S	3.3		10X12.5	0.24	54	ESMG401E□□3R3MJC5S		
560	22X40	0.15	1,470	ESMG161E□□561MP40S	4.7		10X16	0.24	71	ESMG401E□□4R7MJ16S		
680	25.4X40	0.15	1,570	ESMG161E□□681MQ40S	10		10X20	0.24	115	ESMG401E□□100MJ20S		
200	3.3	6.3X11	0.20	40	ESMG201E□□3R3MF11D		22	12.5X25	0.24	205	ESMG401E□□220MK25S	
	4.7	8X11.5	0.20	55	ESMG201E□□4R7MHB5D	33	16X25	0.24	275	ESMG401E□□330ML25S		
	10	10X12.5	0.20	94	ESMG201E□□100MJC5S	33	20X20	0.15	260	ESMG401E□□330MN20S		

□ : Lead forming / Taping code

◆STANDARD RATINGS

□ is non solvent-proof.

WV (Vdc)	Cap (μF)	Case size φDXL(mm)	tanδ	Rated ripple current (mA <sub>rms</sub> /85°C, 120Hz)	Part No.
400	47	16×31.5	0.24	350	ESMG401E□□470MLN3S
	56	20×25	0.15	350	ESMG401E□□560MN25S
	68	20×30	0.15	420	ESMG401E□□680MN30S
	100	20×35	0.15	520	ESMG401E□□101MN35S
	100	22×30	0.15	520	ESMG401E□□101MP30S
	120	20×40	0.15	580	ESMG401E□□121MN40S
	120	22×35	0.15	580	ESMG401E□□121MP35S
	180	25.4×40	0.15	790	ESMG401E□□181MQ40S
450	0.47	10×12.5	0.24	13	ESMG451E□□R47MJC5S
	1.0	10×12.5	0.24	19	ESMG451E□□1R0MJC5S
	2.2	10×12.5	0.24	32	ESMG451E□□2R2MJC5S
	3.3	10×16	0.24	44	ESMG451E□□3R3MJ16S
	4.7	10×20	0.24	56	ESMG451E□□4R7MJ20S
	10	12.5×20	0.24	91	ESMG451E□□100MK20S

WV (Vdc)	Cap (μF)	Case size φDXL(mm)	tanδ	Rated ripple current (mA <sub>rms</sub> /85°C, 120Hz)	Part No.
450	22	16×25	0.24	165	ESMG451E□□220ML25S
	22	20×20	0.20	180	ESMG451E□□220MN20S
	33	16×31.5	0.24	215	ESMG451E□□330MLN3S
	33	20×25	0.20	240	ESMG451E□□330MN25S
	47	16×35.5	0.24	265	ESMG451E□□470MLP1S
	47	20×25	0.20	290	ESMG451E□□470MN25S
	56	20×30	0.20	320	ESMG451E□□560MN30S
	68	20×35	0.20	370	ESMG451E□□680MN35S
	68	22×30	0.20	370	ESMG451E□□680MP30S
	82	20×40	0.20	420	ESMG451E□□820MN40S
	82	22×35	0.20	420	ESMG451E□□820MP35S
	100	22×40	0.20	470	ESMG451E□□101MP40S
	120	25.4×40	0.20	520	ESMG451E□□121MQ40S

□ : Lead forming / Taping code

◆RATED RIPPLE CURRENT MULTIPLIERS

●Frequency Multipliers

(φ5 to φ18)

Capacitance (μF)	Frequency (Hz)					
	50	120	300	1k	10k	100k
0.1 to 4.7	0.65	1.00	1.35	1.75	2.30	2.50
10 to 47	0.75	1.00	1.25	1.50	1.75	1.80
100 to 1,000	0.80	1.00	1.15	1.30	1.40	1.50
2,200 to	0.85	1.00	1.03	1.05	1.08	1.08

(φ20 to φ25.4)

Rated Voltage (V <sub>dc</sub> )	Frequency (Hz)					
	50	120	300	1k	10k	100k
6.3 to 50	0.95	1.00	1.03	1.05	1.08	1.08
63 to 100	0.92	1.00	1.07	1.13	1.19	1.20
160 to 250	0.81	1.00	1.17	1.32	1.45	1.50
315 to 450	0.77	1.00	1.16	1.30	1.41	1.43

The endurance of capacitors is shorted with internal heating produced by ripple current at the rate of halving the lifetime with every 5°C rise. When long life performance is required in actual use, the rms ripple current has to be reduced.

# KMG Series

- Downsized from KME series
- Solvent-proof type except 350 to 450V<sub>dc</sub>  
(see PRECAUTIONS AND GUIDELINES)
- RoHS Compliant

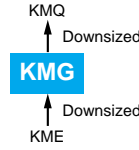

## ◆ SPECIFICATIONS

Items	Characteristics																						
Category	-55 to +105°C(6.3 to 100V <sub>dc</sub> ) -40 to +105°C(160 to 400V <sub>dc</sub> ) -25 to +105°C(450V <sub>dc</sub> )																						
Temperature Range																							
Rated Voltage Range	6.3 to 450V <sub>dc</sub>																						
Capacitance Tolerance	±20% (M) (at 20°C, 120Hz)																						
Leakage Current	6.3 to 100V <sub>dc</sub>																						
	I=0.03CV or 4µA, whichever is greater.																						
	160 to 450V <sub>dc</sub>																						
	<table border="1"> <thead> <tr> <th>CV</th> <th>Time</th> <th>After 1minute</th> <th>After 5minutes</th> </tr> </thead> <tbody> <tr> <td>CV≤1,000</td> <td></td> <td>I=0.1CV+40 max.</td> <td>I=0.03CV+15 max.</td> </tr> <tr> <td>CV&gt;1,000</td> <td></td> <td>I=0.04CV+100 max.</td> <td>I=0.02CV+25 max.</td> </tr> </tbody> </table>												CV	Time	After 1minute	After 5minutes	CV≤1,000		I=0.1CV+40 max.	I=0.03CV+15 max.	CV>1,000		I=0.04CV+100 max.
CV	Time	After 1minute	After 5minutes																				
CV≤1,000		I=0.1CV+40 max.	I=0.03CV+15 max.																				
CV>1,000		I=0.04CV+100 max.	I=0.02CV+25 max.																				
(at 20°C after 1 minute) (at 20°C)																							
Dissipation Factor (tanδ)	Where, I : Max. leakage current (µA), C : Nominal capacitance (µF), V : Rated voltage (V)																						
	Rated voltage (V <sub>dc</sub> )	6.3V	10V	16V	25V	35V	50V	63V	100V	160 to 250V	350 to 400V	450V											
	tanδ (Max.)	0.34	0.24	0.20	0.16	0.14	0.12	0.10	0.08	0.20	0.24	0.24											
When nominal capacitance exceeds 1,000µF, add 0.02 to the value above for each 1,000µF increase. (at 20°C, 120Hz)																							
Low Temperature Characteristics (Max. Impedance Ratio)	Rated voltage (V <sub>dc</sub> )	6.3V	10V	16V	25V	35V	50V	63V	100V	160 to 250V	350 to 400V	450V											
	Z(-25°C)/Z(+20°C)	5	4	3	2	2	2	2	2	3	6	6											
	Z(-40°C)/Z(+20°C)	12	10	8	5	4	3	3	3	4	6	—											
(at 120Hz)																							
Endurance	The following specifications shall be satisfied when the capacitors are restored to 20°C after subjected to DC voltage with the rated ripple current is applied for 1,000 hours (2,000 hours to meet the following two conditions 1) : 160V <sub>dc</sub> and larger, 2) : φ12.5 and larger) at 105°C.																						
	Capacitance change	≤±20% of the initial value																					
	D.F. (tanδ)	≤200% of the initial specified value																					
	Leakage current	≤The initial specified value																					
Shelf Life	The following specifications shall be satisfied when the capacitors are restored to 20°C after exposing them for 1,000 hours at 105°C without voltage applied.																						
	Rated voltage	6.3 to 100V <sub>dc</sub>						160 to 450V <sub>dc</sub>															
	Capacitance change	≤±20% of the initial value						≤±20% of the initial value															
	D.F. (tanδ)	≤200% of the initial specified value						≤200% of the initial specified value															
	Leakage current	≤The initial specified value						≤500% of the initial specified value															

## ◆ DIMENSIONS [mm]

- Terminal Code : E

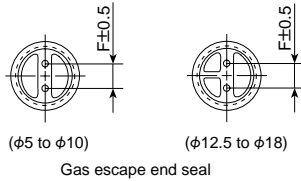
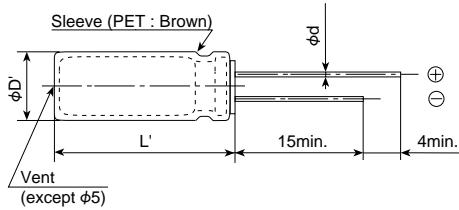

φD	5	6.3	8	10	12.5	16	18
φd	0.5	0.5	0.6	0.6	0.6	0.8	0.8
F	2.0	2.5	3.5	5.0	5.0	7.5	7.5
φD'	φD+0.5max.						
L'	L+1.5max						

## ◆ PART NUMBERING SYSTEM

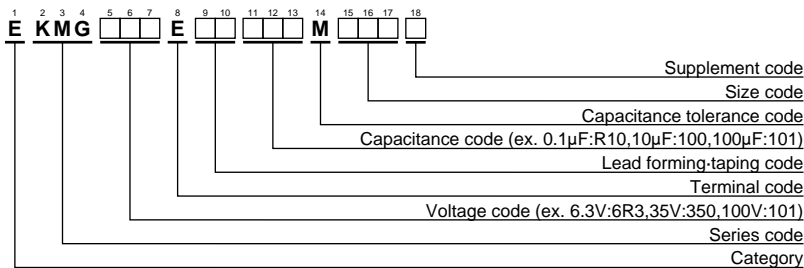

Please refer to "A guide to global code (radial lead type)"

◆STANDARD RATINGS

WV (Vdc)	Cap (μF)	Case size φD×L(mm)	tanδ	Rated ripple current (mA rms/ 105°C, 120Hz)	Part No.	WV (Vdc)	Cap (μF)	Case size φD×L(mm)	tanδ	Rated ripple current (mA rms/ 105°C, 120Hz)	Part No.
6.3	33	5×11	0.34	54	EKMG6R3E□□330ME11D	35	3,300	16×35.5	0.18	1,610	EKMG350E□□332MLP1S
	47	5×11	0.34	64	EKMG6R3E□□470ME11D		4,700	18×35.5	0.20	1,910	EKMG350E□□472MMP1S
	100	5×11	0.34	94	EKMG6R3E□□101ME11D		0.10	5×11	0.12	1.3	EKMG500E□□R10ME11D
	220	5×11	0.34	140	EKMG6R3E□□221ME11D		0.22	5×11	0.12	2.9	EKMG500E□□R22ME11D
	330	6.3×11	0.34	190	EKMG6R3E□□331MF11D		0.33	5×11	0.12	4.3	EKMG500E□□R33ME11D
	470	6.3×11	0.34	230	EKMG6R3E□□471MF11D		0.47	5×11	0.12	6.2	EKMG500E□□R47ME11D
	1,000	8×11.5	0.34	380	EKMG6R3E□□102MHB5D		1.0	5×11	0.12	13	EKMG500E□□R10ME11D
	2,200	10×20	0.36	710	EKMG6R3E□□222MJ20S		2.2	5×11	0.12	20	EKMG500E□□R22ME11D
	3,300	10×20	0.38	840	EKMG6R3E□□332MJ20S		3.3	5×11	0.12	25	EKMG500E□□R33ME11D
	4,700	12.5×20	0.40	1,090	EKMG6R3E□□472MK20S		4.7	5×11	0.12	30	EKMG500E□□R47ME11D
	6,800	12.5×25	0.44	1,350	EKMG6R3E□□682MK25S		10	5×11	0.12	40	EKMG500E□□R100ME11D
	10,000	16×25	0.52	1,650	EKMG6R3E□□103ML25S		22	5×11	0.12	65	EKMG500E□□R220ME11D
	15,000	16×35.5	0.62	2,010	EKMG6R3E□□153MLP1S		33	5×11	0.12	90	EKMG500E□□R33ME11D
2,200	18×40	0.76	2,350	EKMG6R3E□□223MM40S	47	6.3×11	0.12	110	EKMG500E□□R470MF11D		
10	22	5×11	0.24	46	EKMG100E□□220ME11D	100	8×11.5	0.12	180	EKMG500E□□R101MHB5D	
	33	5×11	0.24	57	EKMG100E□□330ME11D	220	10×12.5	0.12	300	EKMG500E□□R221MJC5S	
	47	5×11	0.24	68	EKMG100E□□470ME11D	330	10×16	0.12	410	EKMG500E□□R331MJ16S	
	100	5×11	0.24	100	EKMG100E□□101ME11D	470	10×20	0.12	530	EKMG500E□□R471MJ20S	
	220	6.3×11	0.24	170	EKMG100E□□221MF11D	1,000	12.5×25	0.12	950	EKMG500E□□R102MK25S	
	330	6.3×11	0.24	200	EKMG100E□□331MF11D	2,200	16×35.5	0.14	1,470	EKMG500E□□R222MLP1S	
	470	8×11.5	0.24	250	EKMG100E□□471MHB5D	3,300	18×35.5	0.16	1,770	EKMG500E□□R332MMP1S	
	1,000	10×12.5	0.24	460	EKMG100E□□102MJC5S	10	5×11	0.10	46	EKMG630E□□R100ME11D	
	2,200	10×20	0.26	760	EKMG100E□□222MJ20S	22	5×11	0.10	71	EKMG630E□□R220ME11D	
	3,300	12.5×20	0.28	1,000	EKMG100E□□332MK20S	33	6.3×11	0.10	100	EKMG630E□□R330MF11D	
	4,700	12.5×25	0.30	1,260	EKMG100E□□472MK25S	47	6.3×11	0.10	120	EKMG630E□□R470MF11D	
	6,800	16×25	0.34	1,570	EKMG100E□□682ML25S	100	10×12.5	0.10	215	EKMG630E□□R101MJC5S	
	10,000	16×35.5	0.42	1,890	EKMG100E□□103MLP1S	220	10×16	0.10	335	EKMG630E□□R221MJ16S	
15,000	18×35.5	0.52	2,180	EKMG100E□□153MMP1S	330	10×20	0.10	510	EKMG630E□□R331MJ20S		
16	10	5×11	0.20	34	EKMG160E□□100ME11D	470	12.5×20	0.10	640	EKMG630E□□R471MK20S	
	22	5×11	0.20	51	EKMG160E□□220ME11D	1,000	16×25	0.10	930	EKMG630E□□R102ML25S	
	33	5×11	0.20	63	EKMG160E□□330ME11D	0.10	5×11	0.08	1.5	EKMG101E□□R10ME11D	
	47	5×11	0.20	75	EKMG160E□□470ME11D	0.22	5×11	0.08	3.4	EKMG101E□□R22ME11D	
	100	5×11	0.20	110	EKMG160E□□101ME11D	0.33	5×11	0.08	5.0	EKMG101E□□R33ME11D	
	220	6.3×11	0.20	180	EKMG160E□□221MF11D	0.47	5×11	0.08	7.1	EKMG101E□□R47ME11D	
	330	8×11.5	0.20	260	EKMG160E□□331MHB5D	1.0	5×11	0.08	15	EKMG101E□□R10ME11D	
	470	8×11.5	0.20	310	EKMG160E□□471MHB5D	2.2	5×11	0.08	21	EKMG101E□□R22ME11D	
	1,000	10×16	0.20	560	EKMG160E□□102MJ16S	3.3	5×11	0.08	29	EKMG101E□□R33ME11D	
	2,200	12.5×20	0.22	920	EKMG160E□□222MK20S	4.7	5×11	0.08	32	EKMG101E□□R47ME11D	
	3,300	12.5×25	0.24	1,170	EKMG160E□□332MK25S	10	6.3×11	0.08	54	EKMG101E□□R100MF11D	
	4,700	16×25	0.26	1,480	EKMG160E□□472ML25S	22	8×11.5	0.08	93	EKMG101E□□R220MHB5D	
	6,800	16×31.5	0.30	1,780	EKMG160E□□682MLN3S	33	8×11.5	0.08	130	EKMG101E□□R330MHB5D	
10,000	18×35.5	0.38	2,060	EKMG160E□□103MMP1S	47	10×12.5	0.08	165	EKMG101E□□R470MJC5S		
25	4.7	5×11	0.16	25	EKMG250E□□47R7ME11D	100	10×20	0.08	265	EKMG101E□□R101MJ20S	
	10	5×11	0.16	36	EKMG250E□□100ME11D	220	12.5×25	0.08	440	EKMG101E□□R221MK25S	
	22	5×11	0.16	54	EKMG250E□□220ME11D	330	16×25	0.08	540	EKMG101E□□R331ML25S	
	33	5×11	0.16	67	EKMG250E□□330ME11D	470	16×31.5	0.08	715	EKMG101E□□R471MLN3S	
	47	5×11	0.16	80	EKMG250E□□470ME11D	1,000	18×40	0.08	985	EKMG101E□□R102MM40S	
	100	6.3×11	0.16	130	EKMG250E□□101MF11D	3.3	6.3×11	0.20	28	EKMG161E□□R333MF11D	
	220	8×11.5	0.16	230	EKMG250E□□221MHB5D	4.7	6.3×11	0.20	34	EKMG161E□□R477MF11D	
	330	8×11.5	0.16	310	EKMG250E□□331MHB5D	10	10×12.5	0.20	67	EKMG161E□□R100MJC5S	
	470	10×12.5	0.16	380	EKMG250E□□471MJC5S	22	10×20	0.20	120	EKMG161E□□R220MJ20S	
	1,000	10×20	0.16	680	EKMG250E□□102MJ20S	33	10×20	0.20	145	EKMG161E□□R330MJ20S	
	2,200	12.5×25	0.18	1,090	EKMG250E□□222MK25S	47	12.5×20	0.20	195	EKMG161E□□R470MK20S	
	3,300	16×25	0.20	1,400	EKMG250E□□332ML25S	100	16×25	0.20	335	EKMG161E□□R101ML25S	
	4,700	16×31.5	0.22	1,710	EKMG250E□□472MLN3S	220	16×31.5	0.20	540	EKMG161E□□R221MLN3S	
6,800	18×35.5	0.26	2,040	EKMG250E□□682MMP1S	330	18×35.5	0.20	705	EKMG161E□□R331MMP1S		
35	4.7	5×11	0.14	28	EKMG350E□□47R7ME11D	3.3	6.3×11	0.20	28	EKMG201E□□R333MF11D	
	10	5×11	0.14	41	EKMG350E□□100ME11D	4.7	8×11.5	0.20	39	EKMG201E□□R477MHB5D	
	22	5×11	0.14	61	EKMG350E□□220ME11D	10	10×16	0.20	74	EKMG201E□□R100MJ16S	
	33	5×11	0.14	75	EKMG350E□□330ME11D	22	10×20	0.20	120	EKMG201E□□R220MJ20S	
	47	5×11	0.14	90	EKMG350E□□470ME11D	33	12.5×20	0.20	160	EKMG201E□□R330MK20S	
	100	6.3×11	0.14	150	EKMG350E□□101MF11D	47	12.5×20	0.20	195	EKMG201E□□R470MK20S	
	220	8×11.5	0.14	270	EKMG350E□□221MHB5D	100	16×25	0.20	335	EKMG201E□□R101ML25S	
	330	10×12.5	0.14	350	EKMG350E□□331MJC5S	220	18×35.5	0.20	575	EKMG201E□□R221MMP1S	
	470	10×16	0.14	460	EKMG350E□□471MJ16S	2.2	6.3×11	0.20	23	EKMG251E□□R222MF11D	
	1,000	12.5×20	0.14	810	EKMG350E□□102MK20S	3.3	8×11.5	0.20	32	EKMG251E□□R333MHB5D	
	2,200	16×25	0.16	1,260	EKMG350E□□222ML25S	4.7	8×11.5	0.20	39	EKMG251E□□R477MHB5D	

□ □ : Lead forming / Taping code

### ◆STANDARD RATINGS

is non solvent-proof.

WV (Vdc)	Cap (μF)	Case size φDXL(mm)	tanδ	Rated ripple current (mA <sub>rms</sub> /105°C,120Hz)	Part No.
250	10	10×16	0.20	74	EKMG251E□□100MJ16S
	22	12.5×20	0.20	130	EKMG251E□□220MK20S
	33	12.5×20	0.20	160	EKMG251E□□330MK20S
	47	12.5×25	0.20	210	EKMG251E□□470MK25S
	100	16×31.5	0.20	365	EKMG251E□□101MLN3S
	220	18×40	0.20	585	EKMG251E□□221MM40S
350	0.47	6.3×11	0.24	11	EKMG351E□□R47MF11D
	1.0	6.3×11	0.24	15	EKMG351E□□1R0MF11D
	2.2	8×11.5	0.24	26	EKMG351E□□2R2MHB5D
	3.3	10×12.5	0.24	38	EKMG351E□□3R3MJC5S
	4.7	10×16	0.24	50	EKMG351E□□4R7MJ16S
	10	10×20	0.24	80	EKMG351E□□100MJ20S
	22	12.5×20	0.24	130	EKMG351E□□220MK20S
	33	16×25	0.24	195	EKMG351E□□330ML25S
	47	16×25	0.24	230	EKMG351E□□470ML25S
100	18×31.5	0.24	375	EKMG351E□□101MMN3S	

□□ : Lead forming / Taping code

WV (Vdc)	Cap (μF)	Case size φDXL(mm)	tanδ	Rated ripple current (mA <sub>rms</sub> /105°C,120Hz)	Part No.
400	1.0	6.3×11	0.24	15	EKMG401E□□1R0MF11D
	2.2	8×11.5	0.24	26	EKMG401E□□2R2MHB5D
	3.3	10×12.5	0.24	38	EKMG401E□□3R3MJC5S
	4.7	10×16	0.24	50	EKMG401E□□4R7MJ16S
	10	10×20	0.24	80	EKMG401E□□100MJ20S
	22	12.5×25	0.24	145	EKMG401E□□220MK25S
	33	16×25	0.24	195	EKMG401E□□330ML25S
	47	16×31.5	0.24	250	EKMG401E□□470MLN3S
	100	16×40	0.24	350	EKMG401E□□101ML40S
	450	0.47	10×12.5	0.24	9.0
1.0		10×12.5	0.24	13	EKMG451E□□1R0MJC5S
2.2		10×12.5	0.24	23	EKMG451E□□2R2MJC5S
3.3		10×16	0.24	31	EKMG451E□□3R3MJ16S
4.7		10×20	0.24	40	EKMG451E□□4R7MJ20S
10		12.5×20	0.24	65	EKMG451E□□100MK20S
22		16×25	0.24	115	EKMG451E□□220ML25S
33		16×31.5	0.24	155	EKMG451E□□330MLN3S
47		16×35.5	0.24	185	EKMG451E□□470MLP1S

### ◆RATED RIPPLE CURRENT MULTIPLIERS

#### ●Frequency Multipliers

Capacitance (μF) \ Frequency (Hz)	50	120	300	1k	10k	100k
0.1 to 4.7	0.65	1.00	1.35	1.75	2.30	2.50
10 to 47	0.75	1.00	1.25	1.50	1.75	1.80
100 to 1,000	0.80	1.00	1.15	1.30	1.40	1.50
2,200 to	0.85	1.00	1.03	1.05	1.08	1.08

The endurance of capacitors is shorted with internal heating produced by ripple current at the rate of halving the lifetime with every 5°C rise. When long life performance is required in actual use, the rms ripple current has to be reduced.



# SME-BP Series

- Standard Bi-polarized type
- Endurance : 2,000 hours at 85°C
- Solvent-proof type (see PRECAUTIONS AND GUIDELINES)
- RoHS Compliant

SME-BP

Bi-polarized  
SME



## ◆ SPECIFICATIONS

Items	Characteristics										
Category	-40 to +85°C										
Temperature Range	-40 to +85°C										
Rated Voltage Range	6.3 to 100V <sub>dc</sub>										
Capacitance Tolerance	±20% (M) (at 20°C, 120Hz)										
Leakage Current	I=0.06CV or 10μA, whichever is greater. (at 20°C after 2 minutes) I=0.03CV or 3μA, whichever is greater. (at 20°C after 5 minutes) Where, I : Max. leakage current (μA), C : Nominal capacitance (μF), V : Rated voltage (V)										
Dissipation Factor (tanδ)	Rated voltage (V <sub>dc</sub> )	6.3V	10V	16V	25V	35V	50V	63V	80V	100V	
	tanδ (Max.)	0.24	0.24	0.20	0.20	0.16	0.14	0.12	0.12	0.10	
	When nominal capacitance exceeds 1,000μF, add 0.02 to the value above for each 1,000μF increase. (at 20°C, 120Hz)										
Low Temperature Characteristics (Max. Impedance Ratio)	Rated voltage (V <sub>dc</sub> )	6.3V	10V	16V	25V	35V	50V	63V	80V	100V	
	Z(-25°C)/Z(+20°C)	4	3	2	2	2	2	2	2	2	
	Z(-40°C)/Z(+20°C)	10	8	6	4	3	3	3	3	3	
	(at 120Hz)										
Endurance	The following specifications shall be satisfied when the capacitors are restored to 20°C after the rated voltage is applied for 2,000 hours at 85°C, however the polarization shall be reversed every 250 hours.										
	Rated voltage	6.3 to 16V <sub>dc</sub>					25 to 100V <sub>dc</sub>				
	Capacitance change	≤±25% of the initial value					≤±20% of the initial value				
	D.F. (tanδ)	≤150% of the initial specified value									
	Leakage current	≤The initial specified value									
Shelf Life	The following specifications shall be satisfied when the capacitors are restored to 20°C after exposing them for 1,000 hours at 85°C without voltage applied.										
	Rated voltage	6.3 to 16V <sub>dc</sub>					25 to 100V <sub>dc</sub>				
	Capacitance change	≤±25% of the initial value					≤±20% of the initial value				
	D.F. (tanδ)	≤150% of the initial specified value									
	Leakage current	≤The initial specified value									

## ◆ DIMENSIONS [mm]

- Terminal Code : E

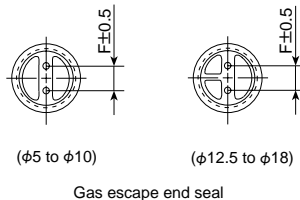
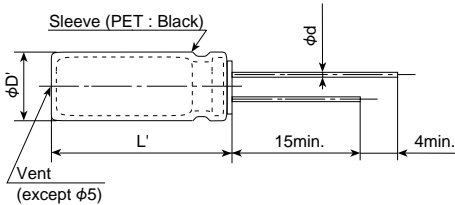

φD	5	6.3	8	10	12.5	16	18
φd	0.5	0.5	0.6	0.6	0.6	0.8	0.8
F	2.0	2.5	3.5	5.0	5.0	7.5	7.5
φD'	φD+0.5max.						
L'	L+1.5max.						

## ◆ PART NUMBERING SYSTEM

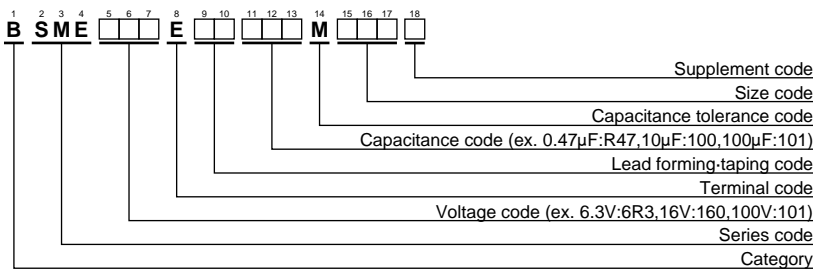

Please refer to "A guide to global code (radial lead type)"

◆STANDARD RATINGS

WV (Vdc)	Cap (μF)	Case size φD×L(mm)	tanδ	Rated ripple current (mA <sub>rms</sub> /85°C,120Hz)	Part No.	WV (Vdc)	Cap (μF)	Case size φD×L(mm)	tanδ	Rated ripple current (mA <sub>rms</sub> /85°C,120Hz)	Part No.
6.3	33	5×11	0.24	64	BSME6R3E□□330ME11D	35	220	12.5×20	0.16	410	BSME350E□□221MK20S
	47	5×11	0.24	76	BSME6R3E□□470ME11D		330	12.5×20	0.16	505	BSME350E□□331MK20S
	100	6.3×11	0.24	125	BSME6R3E□□101MF11D		470	12.5×25	0.16	655	BSME350E□□471MK25S
	220	8×11.5	0.24	215	BSME6R3E□□221MHB5D		1,000	16×31.5	0.16	1,140	BSME350E□□102MLN3S
	330	8×11.5	0.24	265	BSME6R3E□□331MHB5D		0.47	5×11	0.14	11	BSME500E□□R47ME11D
	470	10×12.5	0.24	370	BSME6R3E□□471MJC5S		1.0	5×11	0.14	17	BSME500E□□1R0ME11D
	1,000	10×20	0.24	650	BSME6R3E□□102MJ20S		2.2	5×11	0.14	25	BSME500E□□2R2ME11D
	2,200	12.5×25	0.26	1,160	BSME6R3E□□222MK25S		3.3	5×11	0.14	27	BSME500E□□3R3ME11D
	3,300	16×25	0.28	1,570	BSME6R3E□□332ML25S		4.7	5×11	0.14	34	BSME500E□□4R7ME11D
	4,700	16×31.5	0.30	2,020	BSME6R3E□□472MLN3S		10	6.3×11	0.14	52	BSME500E□□100MF11D
6,800	18×35.5	0.34	2,600	BSME6R3E□□682MMP1S	22	8×11.5	0.14	89	BSME500E□□220MHB5D		
10	22	5×11	0.24	57	BSME100E□□220ME11D	33	8×11.5	0.14	105	BSME500E□□330MHB5D	
	33	5×11	0.24	64	BSME100E□□330ME11D	47	10×12.5	0.14	150	BSME500E□□470MJC5S	
	47	5×11	0.24	76	BSME100E□□470ME11D	100	10×20	0.14	265	BSME500E□□101MJ20S	
	100	6.3×11	0.24	125	BSME100E□□101MF11D	220	12.5×25	0.14	480	BSME500E□□221MK25S	
	220	8×11.5	0.24	215	BSME100E□□221MHB5D	330	16×25	0.14	650	BSME500E□□331ML25S	
	330	10×16	0.24	345	BSME100E□□331MJ16S	470	16×31.5	0.14	835	BSME500E□□471MLN3S	
	470	10×16	0.24	410	BSME100E□□471MJ16S	3.3	5×11	0.12	28	BSME630E□□3R3ME11D	
	1,000	12.5×20	0.24	720	BSME100E□□102MK20S	4.7	6.3×11	0.12	34	BSME630E□□4R7MF11D	
	2,200	16×25	0.26	1,280	BSME100E□□222ML25S	10	6.3×11	0.12	57	BSME630E□□100MF11D	
	3,300	16×31.5	0.28	1,690	BSME100E□□332MLN3S	22	8×11.5	0.12	95	BSME630E□□220MHB5D	
4,700	18×35.5	0.30	2,160	BSME100E□□472MMP1S	33	10×12.5	0.12	135	BSME630E□□330MJC5S		
16	10	5×11	0.20	42	BSME160E□□100ME11D	47	10×16	0.12	180	BSME630E□□470MJ16S	
	22	5×11	0.20	57	BSME160E□□220ME11D	100	12.5×20	0.12	320	BSME630E□□101MK20S	
	33	5×11	0.20	70	BSME160E□□330ME11D	220	16×25	0.12	575	BSME630E□□221ML25S	
	47	6.3×11	0.20	95	BSME160E□□470MF11D	330	16×31.5	0.12	655	BSME630E□□331MLN3S	
	100	8×11.5	0.20	160	BSME160E□□101MHB5D	470	18×35.5	0.12	965	BSME630E□□471MMP1S	
	220	10×12.5	0.20	275	BSME160E□□221MJC5S	2.2	5×11	0.12	29	BSME800E□□2R2ME11D	
	330	10×16	0.20	375	BSME160E□□331MJ16S	3.3	6.3×11	0.12	39	BSME800E□□3R3MF11D	
	470	10×20	0.20	485	BSME160E□□471MJ20S	4.7	6.3×11	0.12	47	BSME800E□□4R7MF11D	
	1,000	12.5×25	0.20	855	BSME160E□□102MK25S	10	8×11.5	0.12	65	BSME800E□□100MHB5D	
	2,200	16×31.5	0.22	1,510	BSME160E□□222MLN3S	22	10×16	0.12	125	BSME800E□□220MJ16S	
3,300	18×35.5	0.24	1,980	BSME160E□□332MMP1S	33	10×16	0.12	150	BSME800E□□330MJ16S		
25	10	5×11	0.20	42	BSME250E□□100ME11D	47	10×20	0.12	195	BSME800E□□470MJC5S	
	22	6.3×11	0.20	65	BSME250E□□220MF11D	100	12.5×25	0.12	350	BSME800E□□101MK25S	
	33	6.3×11	0.20	80	BSME250E□□330MF11D	220	16×31.5	0.12	615	BSME800E□□221MLN3S	
	47	6.3×11	0.20	95	BSME250E□□470MF11D	330	18×35.5	0.12	755	BSME800E□□331MMP1S	
	100	8×11.5	0.20	160	BSME250E□□101MHB5D	0.47	5×11	0.10	14	BSME101E□□R47ME11D	
	220	10×16	0.20	305	BSME250E□□221MJ16S	1.0	5×11	0.10	21	BSME101E□□1R0ME11D	
	330	12.5×20	0.20	450	BSME250E□□331MK20S	2.2	6.3×11	0.10	34	BSME101E□□2R2MF11D	
	470	12.5×20	0.20	540	BSME250E□□471MK20S	3.3	6.3×11	0.10	39	BSME101E□□3R3MF11D	
	1,000	16×25	0.20	950	BSME250E□□102ML25S	4.7	6.3×11	0.10	47	BSME101E□□4R7MF11D	
	2,200	18×35.5	0.22	1,620	BSME250E□□222MMP1S	10	8×11.5	0.10	71	BSME101E□□100MHB5D	
35	4.7	5×11	0.16	34	BSME350E□□4R7ME11D	22	10×16	0.10	135	BSME101E□□220MJ16S	
	10	5×11	0.16	43	BSME350E□□100ME11D	33	12.5×20	0.10	220	BSME101E□□330MK20S	
	22	6.3×11	0.16	73	BSME350E□□220MF11D	47	12.5×20	0.10	240	BSME101E□□470MK20S	
	33	8×11.5	0.16	100	BSME350E□□330MHB5D	100	16×25	0.10	425	BSME101E□□101ML25S	
	47	8×11.5	0.16	120	BSME350E□□470MHB5D	220	18×35.5	0.10	720	BSME101E□□221MMP1S	
	100	10×16	0.16	230	BSME350E□□101MJ16S						

□□ : Lead forming / Taping code

# KME-BP Series

- Standard Bi-polarized type
- Endurance : 1,000 hours at 105°C
- Solvent-proof type (see PRECAUTIONS AND GUIDELINES)
- RoHS Compliant

KME-BP

Bi-polarized  
KME



## ◆ SPECIFICATIONS

Items	Characteristics										
Category Temperature Range	-55 to +105°C										
Rated Voltage Range	6.3 to 100V <sub>dc</sub>										
Capacitance Tolerance	±20% (M) (at 20°C, 120Hz)										
Leakage Current	I=0.06CV or 10μA, whichever is greater. (at 20°C after 2 minutes) I=0.03CV or 3μA, whichever is greater. (at 20°C after 5 minutes) Where, I : Max. leakage current (μA), C : Nominal capacitance (μF), V : Rated voltage (V)										
Dissipation Factor (tanδ)	Rated voltage (V <sub>dc</sub> )	6.3V	10V	16V	25V	35V	50V	63V	80V	100V	
	tanδ (Max.)	0.24	0.24	0.20	0.20	0.16	0.14	0.12	0.12	0.10	
	When nominal capacitance exceeds 1,000μF, add 0.02 to the value above for each 1,000μF increase. (at 20°C, 120Hz)										
Low Temperature Characteristics (Max. Impedance Ratio)	Rated voltage (V <sub>dc</sub> )	6.3V	10V	16V	25V	35V	50V	63V	80V	100V	
	Z(-25°C)/Z(+20°C)	4	3	2	2	2	2	2	2	2	
	Z(-40°C)/Z(+20°C)	10	8	6	4	3	3	3	3	3	
Endurance	The following specifications shall be satisfied when the capacitors are restored to 20°C after the rated voltage is applied for 1,000 hours at 105°C, however the polarization shall be reversed every 250 hours.										
	Rated voltage	6.3 to 16V <sub>dc</sub>					25 to 100V <sub>dc</sub>				
	Capacitance change	≤±25% of the initial value					≤±20% of the initial value				
	D.F. (tanδ)	≤150% of the initial specified value									
	Leakage current	≤The initial specified value									
Shelf Life	The following specifications shall be satisfied when the capacitors are restored to 20°C after exposing them for 500 hours at 105°C without voltage applied.										
	Rated voltage	6.3 to 16V <sub>dc</sub>					25 to 100V <sub>dc</sub>				
	Capacitance change	≤±25% of the initial value					≤±20% of the initial value				
	D.F. (tanδ)	≤150% of the initial specified value									
	Leakage current	≤The initial specified value									

## ◆ DIMENSIONS [mm]

- Terminal Code : E

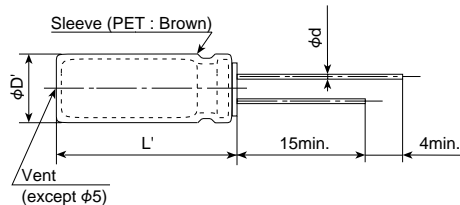

φD	5	6.3	8	10	12.5	16	18
φd	0.5	0.5	0.6	0.6	0.6	0.8	0.8
F	2.0	2.5	3.5	5.0	5.0	7.5	7.5
φD'	φD+0.5max.						
L'	L+1.5max.						

Gas escape end seal

## ◆ PART NUMBERING SYSTEM

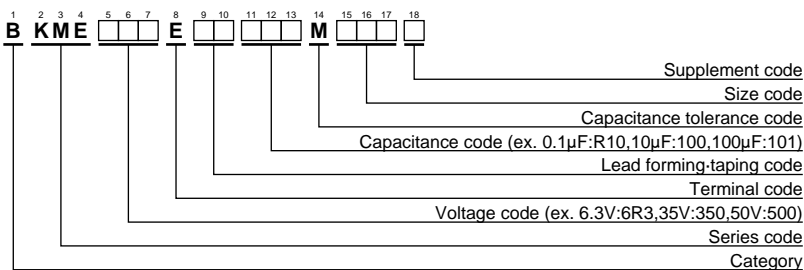

Please refer to "A guide to global code (radial lead type)"

## KME-BP Series

### ◆STANDARD RATINGS

WV (Vdc)	Cap (μF)	Case size φD×L(mm)	tanδ	Rated ripple current (mA <sub>rms</sub> /105°C, 120Hz)	Part No.	WV (Vdc)	Cap (μF)	Case size φD×L(mm)	tanδ	Rated ripple current (mA <sub>rms</sub> /105°C, 120Hz)	Part No.
6.3	33	5×11	0.24	45	BKME6R3E□□330ME11D	35	220	12.5×20	0.16	290	BKME350E□□221MK20S
	47	5×11	0.24	54	BKME6R3E□□470ME11D		330	12.5×20	0.16	350	BKME350E□□331MK20S
	100	6.3×11	0.24	90	BKME6R3E□□101MF11D		470	12.5×25	0.16	465	BKME350E□□471MK25S
	220	8×11.5	0.24	150	BKME6R3E□□221MHB5D		1,000	16×31.5	0.16	805	BKME350E□□102MLN3S
	330	8×11.5	0.24	185	BKME6R3E□□331MHB5D		0.47	5×11	0.14	7.0	BKME500E□□47ME11D
	470	10×12.5	0.24	260	BKME6R3E□□471MJC5S		1.0	5×11	0.14	10	BKME500E□□1R0ME11D
	1,000	10×20	0.24	460	BKME6R3E□□102MJ20S		2.2	5×11	0.14	15	BKME500E□□2R2ME11D
	2,200	12.5×25	0.26	820	BKME6R3E□□222MK25S		3.3	5×11	0.14	18	BKME500E□□3R3ME11D
	3,300	16×25	0.28	1,110	BKME6R3E□□332ML25S		4.7	5×11	0.14	22	BKME500E□□4R7ME11D
	4,700	16×31.5	0.30	1,430	BKME6R3E□□472MLN3S		10	6.3×11	0.14	37	BKME500E□□100MF11D
6,800	18×35.5	0.34	1,830	BKME6R3E□□682MMP1S	22	8×11.5	0.14	63	BKME500E□□220MHB5D		
10	22	5×11	0.24	37	BKME100E□□220ME11D	33	8×11.5	0.14	77	BKME500E□□330MHB5D	
	33	5×11	0.24	45	BKME100E□□330ME11D	47	10×12.5	0.14	105	BKME500E□□470MJC5S	
	47	5×11	0.24	54	BKME100E□□470ME11D	100	10×20	0.14	190	BKME500E□□101MJ20S	
	100	6.3×11	0.24	90	BKME100E□□101MF11D	220	12.5×25	0.14	340	BKME500E□□221MK25S	
	220	8×11.5	0.24	150	BKME100E□□221MHB5D	330	16×25	0.14	460	BKME500E□□331ML25S	
	330	10×16	0.24	240	BKME100E□□331MJ16S	470	16×31.5	0.14	590	BKME500E□□471MLN3S	
	470	10×16	0.24	290	BKME100E□□471MJ16S	3.3	5×11	0.12	20	BKME630E□□3R3ME11D	
	1,000	12.5×20	0.24	510	BKME100E□□102MK20S	4.7	6.3×11	0.12	24	BKME630E□□4R7MF11D	
	2,200	16×25	0.26	910	BKME100E□□222ML25S	10	6.3×11	0.12	40	BKME630E□□100MF11D	
	3,300	16×31.5	0.28	1,200	BKME100E□□332MLN3S	22	8×11.5	0.12	68	BKME630E□□220MHB5D	
4,700	18×35.5	0.30	1,520	BKME100E□□472MMP1S	33	10×12.5	0.12	98	BKME630E□□330MJC5S		
16	10	5×11	0.20	27	BKME160E□□100ME11D	47	10×16	0.12	130	BKME630E□□470MJ16S	
	22	5×11	0.20	40	BKME160E□□220ME11D	100	12.5×20	0.12	225	BKME630E□□101MK20S	
	33	5×11	0.20	49	BKME160E□□330ME11D	220	16×25	0.12	405	BKME630E□□221ML25S	
	47	6.3×11	0.20	67	BKME160E□□470MF11D	330	16×31.5	0.12	535	BKME630E□□331MLN3S	
	100	8×11.5	0.20	110	BKME160E□□101MHB5D	470	18×35.5	0.12	680	BKME630E□□471MMP1S	
	220	10×12.5	0.20	195	BKME160E□□221MJC5S	2.2	5×11	0.12	16	BKME800E□□2R2ME11D	
	330	10×16	0.20	265	BKME160E□□331MJ16S	3.3	6.3×11	0.12	23	BKME800E□□3R3MF11D	
	470	10×20	0.20	345	BKME160E□□471MJ20S	4.7	6.3×11	0.12	27	BKME800E□□4R7MF11D	
	1,000	12.5×25	0.20	605	BKME160E□□102MK25S	10	8×11.5	0.12	46	BKME800E□□100MHB5D	
	2,200	16×31.5	0.22	1,070	BKME160E□□222MLN3S	22	10×16	0.12	89	BKME800E□□220MJ16S	
3,300	18×35.5	0.24	1,400	BKME160E□□332MMP1S	33	10×16	0.12	105	BKME800E□□330MJ16S		
25	10	5×11	0.20	27	BKME250E□□100ME11D	47	10×20	0.12	140	BKME800E□□470MJC5S	
	22	6.3×11	0.20	46	BKME250E□□220MF11D	100	12.5×25	0.12	245	BKME800E□□101MK25S	
	33	6.3×11	0.20	56	BKME250E□□330MF11D	220	16×31.5	0.12	435	BKME800E□□221MLN3S	
	47	6.3×11	0.20	67	BKME250E□□470MF11D	330	18×35.5	0.12	570	BKME800E□□331MMP1S	
	100	8×11.5	0.20	110	BKME250E□□101MHB5D	0.47	5×11	0.10	8.0	BKME101E□□47ME11D	
	220	10×16	0.20	215	BKME250E□□221MJ16S	1.0	5×11	0.10	12	BKME101E□□1R0ME11D	
	330	12.5×20	0.20	320	BKME250E□□331MK20S	2.2	6.3×11	0.10	20	BKME101E□□2R2MF11D	
	470	12.5×20	0.20	380	BKME250E□□471MK20S	3.3	6.3×11	0.10	25	BKME101E□□3R3MF11D	
	1,000	16×25	0.20	670	BKME250E□□102ML25S	4.7	6.3×11	0.10	30	BKME101E□□4R7MF11D	
	2,200	18×35.5	0.22	1,140	BKME250E□□222MMP1S	10	8×11.5	0.10	50	BKME101E□□100MHB5D	
35	4.7	5×11	0.16	21	BKME350E□□4R7ME11D	22	10×16	0.10	97	BKME101E□□220MJ16S	
	10	5×11	0.16	30	BKME350E□□100ME11D	33	12.5×20	0.10	140	BKME101E□□330MK20S	
	22	6.3×11	0.16	51	BKME350E□□220MF11D	47	12.5×20	0.10	170	BKME101E□□470MK20S	
	33	8×11.5	0.16	72	BKME350E□□330MHB5D	100	16×25	0.10	300	BKME101E□□101ML25S	
	47	8×11.5	0.16	86	BKME350E□□470MHB5D	220	18×35.5	0.10	510	BKME101E□□221MMP1S	
	100	10×16	0.16	160	BKME350E□□101MJ16S						

□□ : Lead forming / Taping code

New!

# KZM Series

- Long-Life version of KZH series
- Endurance with ripple current : 6,000 to 10,000 hours at 105°C
- Newly innovative electrolyte is employed to minimize ESR
- Rated voltage range : 6.3 to 50V, Nominal capacitance range : 27 to 10,000μF
- Non solvent-proof
- RoHS Compliant

KZM

↑ Longer life  
KZH  
↑ Lower Z  
KZE



## ◆ SPECIFICATIONS

Items	Characteristics	
Category	-40 to +105°C	
Temperature Range	-40 to +105°C	
Rated Voltage Range	6.3 to 50V <sub>dc</sub>	
Capacitance Tolerance	±20% (M) (at 20°C, 120Hz)	
Leakage Current	I=0.01CV Where, I : Max. leakage current (μA), C : Nominal capacitance (μF), V : Rated voltage (V) (at 20°C after 2 minutes)	
Dissipation Factor (tanδ)	Rated voltage (V <sub>dc</sub> )	6.3V 10V 16V 25V 35V 50V
	tanδ (Max.)	0.22 0.19 0.16 0.14 0.12 0.10
	When nominal capacitance exceeds 1,000μF, add 0.02 to the value above for each 1,000μF increase. (at 20°C, 120Hz)	
Low Temperature Characteristics	Z(-25°C)/Z(+20°C)	2 max.
	Z(-40°C)/Z(+20°C)	3 max.
	(at 120Hz)	
Endurance	The following specifications shall be satisfied when the capacitors are restored to 20°C after subjected to DC voltage with the rated ripple current is applied for the specified period of time at 105°C.	
	Time	φ5 & φ6.3 : 6,000hours φ8 & φ10×12.5 : 8,000hours φ10×16 to φ18 : 10,000hours
	Capacitance change	≤±25% of the initial value (6.3, 10V : ≤±30%)
	D.F. (tanδ)	≤200% of the initial specified value
	Leakage current	≤The initial specified value
Shelf Life	The following specifications shall be satisfied when the capacitors are restored to 20°C after exposing them for 500 hours at 105°C without voltage applied.	
	Capacitance change	≤±25% of the initial value (6.3, 10V : ≤±30%)
	D.F. (tanδ)	≤200% of the initial specified value
	Leakage current	≤The initial specified value

## ◆ DIMENSIONS [mm]

- Terminal Code : E

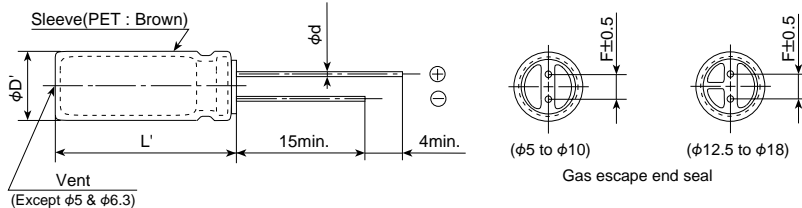

φD	5	6.3	8	10	12.5	16	18
φd	0.5	0.5	0.6	0.6	0.6	0.8	0.8
F	2.0	2.5	3.5	5.0	5.0	7.5	7.5
φD'	φD+0.5max.						
L'	L+1.5max.						

## ◆ PART NUMBERING SYSTEM

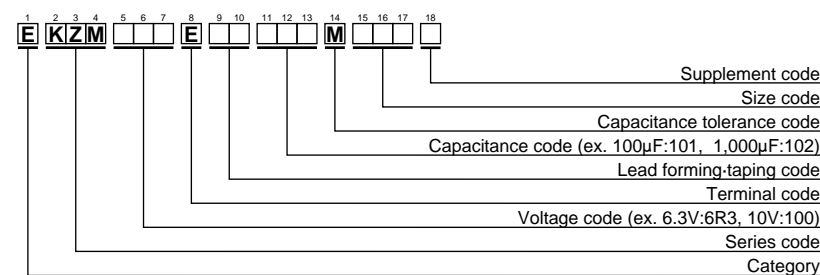

Please refer to "A guide to global code (radial lead type)"

## ◆ RATED RIPPLE CURRENT MULTIPLIERS

- Frequency Multipliers

Capacitance (μF)	Frequency (Hz)			
	120	1k	10k	100k
27 to 180	0.40	0.75	0.90	1.00
220 to 560	0.50	0.85	0.94	1.00
680 to 1,800	0.60	0.87	0.95	1.00
2,200 to 3,900	0.75	0.90	0.95	1.00
4,700 to 10,000	0.85	0.95	0.98	1.00

Note : The endurance of capacitors is shorted with internal heating produced by ripple currents at the rate of halving the lifetime with every 5°C rise. When long life performance is required in actual use, the rms ripple current has to be reduced.

New!

KZM Series

◆STANDARD RATINGS

WV (V <sub>dc</sub> )	Cap (μF)	Case size φD×L(mm)	tanδ	Impedance (Ω <sub>max</sub> /100kHz)		Rated ripple current (mA <sub>rms</sub> /105°C,100kHz)	Part No.
				20°C	-10°C		
6.3	220	5 × 11	0.22	0.22	0.80	345	EKZM6R3E□□221ME11D
	470	6.3 × 11	0.22	0.094	0.35	540	EKZM6R3E□□471MF11D
	820	8 × 11.5	0.22	0.056	0.19	945	EKZM6R3E□□821MHB5D
	1,200	8 × 15	0.22	0.045	0.15	1,250	EKZM6R3E□□122MH15D
	1,200	10 × 12.5	0.22	0.039	0.14	1,330	EKZM6R3E□□122MJC5S
	1,500	8 × 20	0.22	0.029	0.11	1,500	EKZM6R3E□□152MH20D
	1,800	10 × 16	0.22	0.028	0.10	1,760	EKZM6R3E□□182MJ16S
	2,200	10 × 20	0.24	0.020	0.060	1,960	EKZM6R3E□□222MJ20S
	2,700	10 × 25	0.24	0.018	0.054	2,250	EKZM6R3E□□272MJ25S
	3,900	12.5 × 20	0.26	0.017	0.043	2,480	EKZM6R3E□□392MK20S
	4,700	12.5 × 25	0.28	0.015	0.038	2,900	EKZM6R3E□□472MK25S
	5,600	12.5 × 30	0.30	0.013	0.033	3,450	EKZM6R3E□□562MK30S
	6,800	12.5 × 35	0.32	0.012	0.031	3,570	EKZM6R3E□□682MK35S
	6,800	16 × 20	0.32	0.015	0.038	3,250	EKZM6R3E□□682ML20S
8,200	16 × 25	0.36	0.013	0.035	3,630	EKZM6R3E□□822ML25S	
10,000	18 × 25	0.40	0.012	0.031	3,650	EKZM6R3E□□103MM25S	
10	150	5 × 11	0.19	0.22	0.80	345	EKZM100E□□151ME11D
	330	6.3 × 11	0.19	0.094	0.35	540	EKZM100E□□331MF11D
	680	8 × 11.5	0.19	0.056	0.19	945	EKZM100E□□681MHB5D
	1,000	8 × 15	0.19	0.045	0.15	1,250	EKZM100E□□102MH15D
	1,000	10 × 12.5	0.19	0.039	0.14	1,330	EKZM100E□□102MJC5S
	1,500	8 × 20	0.19	0.029	0.11	1,500	EKZM100E□□152MH20D
	1,500	10 × 16	0.19	0.028	0.10	1,760	EKZM100E□□152MJ16S
	1,800	10 × 20	0.19	0.020	0.060	1,960	EKZM100E□□182MJ20S
	2,200	10 × 25	0.19	0.018	0.054	2,250	EKZM100E□□222MJ25S
	2,700	12.5 × 20	0.21	0.017	0.043	2,480	EKZM100E□□272MK20S
	3,900	12.5 × 25	0.21	0.015	0.038	2,900	EKZM100E□□392MK25S
	4,700	12.5 × 30	0.23	0.013	0.033	3,450	EKZM100E□□472MK30S
	4,700	12.5 × 35	0.23	0.012	0.031	3,570	EKZM100E□□472MK35S
	5,600	16 × 20	0.23	0.015	0.038	3,250	EKZM100E□□562ML20S
6,800	16 × 25	0.25	0.013	0.035	3,630	EKZM100E□□682ML25S	
8,200	18 × 25	0.29	0.012	0.031	3,650	EKZM100E□□822MM25S	
16	100	5 × 11	0.16	0.22	0.80	345	EKZM160E□□101ME11D
	220	6.3 × 11	0.16	0.094	0.35	540	EKZM160E□□221MF11D
	470	8 × 11.5	0.16	0.056	0.19	945	EKZM160E□□471MHB5D
	680	8 × 15	0.16	0.045	0.15	1,250	EKZM160E□□681MH15D
	680	10 × 12.5	0.16	0.039	0.14	1,330	EKZM160E□□681MJC5S
	1,000	8 × 20	0.16	0.029	0.11	1,500	EKZM160E□□102MH20D
	1,000	10 × 16	0.16	0.028	0.10	1,760	EKZM160E□□102MJ16S
	1,500	10 × 20	0.16	0.020	0.060	1,960	EKZM160E□□152MJ20S
	1,800	10 × 25	0.16	0.018	0.054	2,250	EKZM160E□□182MJ25S
	2,200	12.5 × 20	0.18	0.017	0.043	2,480	EKZM160E□□222MK20S
	2,700	12.5 × 25	0.18	0.015	0.038	2,900	EKZM160E□□272MK25S
	3,300	12.5 × 30	0.20	0.013	0.033	3,450	EKZM160E□□332MK30S
	3,300	12.5 × 35	0.20	0.012	0.031	3,570	EKZM160E□□332MK35S
	3,900	16 × 20	0.20	0.015	0.038	3,250	EKZM160E□□392ML20S
	4,700	16 × 25	0.22	0.013	0.035	3,630	EKZM160E□□472ML25S
	5,600	18 × 25	0.24	0.012	0.031	3,650	EKZM160E□□562MM25S

□□ : Lead forming / Taping code

New!

KZM Series

◆STANDARD RATINGS

WV (Vdc)	Cap (μF)	Case size φD×L(mm)	tanδ	Impedance (Ωmax/100kHz)		Rated ripple current (mArms/105°C,100kHz)	Part No.
				20°C	-10°C		
25	68	5 × 11	0.14	0.22	0.80	345	EKZM250E□□680ME11D
	150	6.3 × 11	0.14	0.094	0.35	540	EKZM250E□□151MF11D
	330	8 × 11.5	0.14	0.056	0.19	945	EKZM250E□□331MHB5D
	390	8 × 15	0.14	0.045	0.15	1,250	EKZM250E□□391MH15D
	470	10 × 12.5	0.14	0.039	0.14	1,330	EKZM250E□□471MJC5S
	560	8 × 20	0.14	0.029	0.11	1,500	EKZM250E□□561MH20D
	680	10 × 16	0.14	0.028	0.10	1,760	EKZM250E□□681MJ16S
	820	10 × 20	0.14	0.020	0.060	1,960	EKZM250E□□821MJ20S
	1,000	10 × 25	0.14	0.018	0.054	2,250	EKZM250E□□102MJ25S
	1,500	12.5 × 20	0.14	0.017	0.043	2,480	EKZM250E□□152MK20S
	1,800	12.5 × 25	0.14	0.015	0.038	2,900	EKZM250E□□182MK25S
	2,200	12.5 × 30	0.16	0.013	0.033	3,450	EKZM250E□□222MK30S
	2,200	12.5 × 35	0.16	0.012	0.031	3,570	EKZM250E□□222MK35S
	2,700	16 × 20	0.16	0.015	0.038	3,250	EKZM250E□□272ML20S
3,300	16 × 25	0.18	0.013	0.035	3,630	EKZM250E□□332ML25S	
3,900	18 × 25	0.18	0.012	0.031	3,650	EKZM250E□□392MM25S	
35	47	5 × 11	0.12	0.22	0.80	345	EKZM350E□□470ME11D
	100	6.3 × 11	0.12	0.094	0.35	540	EKZM350E□□101MF11D
	220	8 × 11.5	0.12	0.056	0.19	945	EKZM350E□□221MHB5D
	270	8 × 15	0.12	0.045	0.15	1,250	EKZM350E□□271MH15D
	330	10 × 12.5	0.12	0.039	0.14	1,330	EKZM350E□□331MJC5S
	390	8 × 20	0.12	0.029	0.11	1,500	EKZM350E□□391MH20D
	470	10 × 16	0.12	0.028	0.10	1,760	EKZM350E□□471MJ16S
	560	10 × 20	0.12	0.020	0.060	1,960	EKZM350E□□561MJ20S
	680	10 × 25	0.12	0.018	0.054	2,250	EKZM350E□□681MJ25S
	1,000	12.5 × 20	0.12	0.017	0.043	2,480	EKZM350E□□102MK20S
	1,200	12.5 × 25	0.12	0.015	0.038	2,900	EKZM350E□□122MK25S
	1,500	12.5 × 30	0.12	0.013	0.033	3,450	EKZM350E□□152MK30S
	1,500	16 × 20	0.12	0.015	0.038	3,250	EKZM350E□□152ML20S
	1,800	12.5 × 35	0.12	0.012	0.031	3,570	EKZM350E□□182MK35S
2,200	16 × 25	0.14	0.013	0.035	3,630	EKZM350E□□222ML25S	
2,700	18 × 25	0.14	0.012	0.031	3,650	EKZM350E□□272MM25S	
50	27	5 × 11	0.10	0.34	1.18	238	EKZM500E□□270ME11D
	56	6.3 × 11	0.10	0.14	0.50	385	EKZM500E□□560MF11D
	100	8 × 11.5	0.10	0.074	0.22	724	EKZM500E□□101MHB5D
	150	8 × 15	0.10	0.061	0.18	950	EKZM500E□□151MH15D
	150	10 × 12.5	0.10	0.061	0.18	979	EKZM500E□□151MJC5S
	180	8 × 20	0.10	0.046	0.14	1,190	EKZM500E□□181MH20D
	220	10 × 16	0.10	0.042	0.12	1,370	EKZM500E□□221MJ16S
	270	10 × 20	0.10	0.030	0.090	1,580	EKZM500E□□271MJ20S
	330	10 × 25	0.10	0.028	0.085	1,870	EKZM500E□□331MJ25S
	470	12.5 × 20	0.10	0.027	0.068	2,050	EKZM500E□□471MK20S
	680	12.5 × 25	0.10	0.023	0.059	2,410	EKZM500E□□681MK25S
	820	12.5 × 30	0.10	0.021	0.052	2,860	EKZM500E□□821MK30S
	820	12.5 × 35	0.10	0.019	0.051	2,960	EKZM500E□□821MK35S
	1,000	16 × 20	0.10	0.023	0.059	2,730	EKZM500E□□102ML20S
1,200	16 × 25	0.10	0.021	0.056	3,010	EKZM500E□□122ML25S	
1,500	18 × 25	0.10	0.019	0.051	3,290	EKZM500E□□152MM25S	

□□ : Lead forming / Taping code

# KZH Series

- Ultra Low impedance for Personal Computer and Storage Equipment
- Endurance with ripple current: 5,000 to 6,000 hours at 105°C
- Non solvent-proof type
- RoHS Compliant

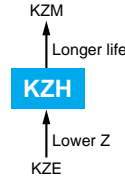

## ◆SPECIFICATIONS

Items	Characteristics												
<b>Category</b> Temperature Range	-40 to +105°C												
<b>Rated Voltage Range</b>	6.3 to 35V <sub>dc</sub>												
<b>Capacitance Tolerance</b>	±20% (M) (at 20°C, 120Hz)												
<b>Leakage Current</b>	I=0.01CV or 3µA, whichever is greater. Where, I : Max. leakage current (µA), C : Nominal capacitance (µF), V : Rated voltage (V) (at 20°C after 2 minutes)												
<b>Dissipation Factor (tanδ)</b>	<table border="1"> <tr> <td>Rated voltage (V<sub>dc</sub>)</td> <td>6.3V</td> <td>10V</td> <td>16V</td> <td>25V</td> <td>35V</td> </tr> <tr> <td>tanδ (Max.)</td> <td>0.22</td> <td>0.19</td> <td>0.16</td> <td>0.14</td> <td>0.12</td> </tr> </table> <p>When nominal capacitance exceeds 1,000µF, add 0.02 to the value above for each 1,000µF increase. (at 20°C, 120Hz)</p>	Rated voltage (V <sub>dc</sub> )	6.3V	10V	16V	25V	35V	tanδ (Max.)	0.22	0.19	0.16	0.14	0.12
Rated voltage (V <sub>dc</sub> )	6.3V	10V	16V	25V	35V								
tanδ (Max.)	0.22	0.19	0.16	0.14	0.12								
<b>Low Temperature Characteristics (Max. Impedance Ratio)</b>	<table border="1"> <tr> <td>Z (-25°C) / Z (+20°C)</td> <td>2max.</td> </tr> <tr> <td>Z (-40°C) / Z (+20°C)</td> <td>3max.</td> </tr> </table> <p>(at 120Hz)</p>	Z (-25°C) / Z (+20°C)	2max.	Z (-40°C) / Z (+20°C)	3max.								
Z (-25°C) / Z (+20°C)	2max.												
Z (-40°C) / Z (+20°C)	3max.												
<b>Endurance</b>	<p>The following specifications shall be satisfied when the capacitors are restored to 20°C after subjected to DC voltage with the rated ripple current is applied for the specified period of time at 105°C.</p> <table border="1"> <tr> <td>Time</td> <td>φ5 &amp; φ6.3 : 5,000hours φ8 to φ16 : 6,000hours</td> </tr> <tr> <td>Capacitance change</td> <td>≤±25% of the initial value (6.3, 10V : ≤±30%)</td> </tr> <tr> <td>D.F. (tanδ)</td> <td>≤200% of the initial specified value</td> </tr> <tr> <td>Leakage current</td> <td>≤The initial specified value</td> </tr> </table>	Time	φ5 & φ6.3 : 5,000hours φ8 to φ16 : 6,000hours	Capacitance change	≤±25% of the initial value (6.3, 10V : ≤±30%)	D.F. (tanδ)	≤200% of the initial specified value	Leakage current	≤The initial specified value				
Time	φ5 & φ6.3 : 5,000hours φ8 to φ16 : 6,000hours												
Capacitance change	≤±25% of the initial value (6.3, 10V : ≤±30%)												
D.F. (tanδ)	≤200% of the initial specified value												
Leakage current	≤The initial specified value												
<b>Shelf Life</b>	<p>The following specifications shall be satisfied when the capacitors are restored to 20°C after exposing them for 500 hours at 105°C without voltage applied.</p> <table border="1"> <tr> <td>Capacitance change</td> <td>≤±25% of the initial value (6.3, 10V : ≤±30%)</td> </tr> <tr> <td>D.F. (tanδ)</td> <td>≤200% of the initial specified value</td> </tr> <tr> <td>Leakage current</td> <td>≤The initial specified value</td> </tr> </table>	Capacitance change	≤±25% of the initial value (6.3, 10V : ≤±30%)	D.F. (tanδ)	≤200% of the initial specified value	Leakage current	≤The initial specified value						
Capacitance change	≤±25% of the initial value (6.3, 10V : ≤±30%)												
D.F. (tanδ)	≤200% of the initial specified value												
Leakage current	≤The initial specified value												

## ◆DIMENSIONS [mm]

- Terminal Code : E

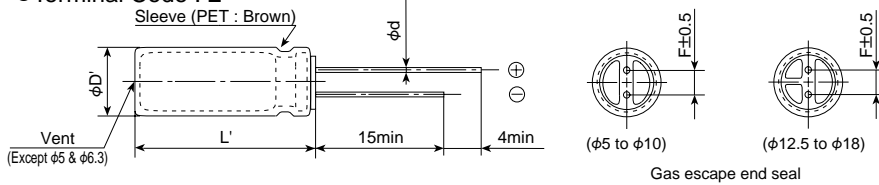

φD	5	6.3	8	10	12.5	16
φd	0.5	0.5	0.6	0.6	0.6	0.8
F	2.0	2.5	3.5	5.0	5.0	7.5
φD'	φD+0.5max.					
L'	L+1.5max.					

## ◆PART NUMBERING SYSTEM

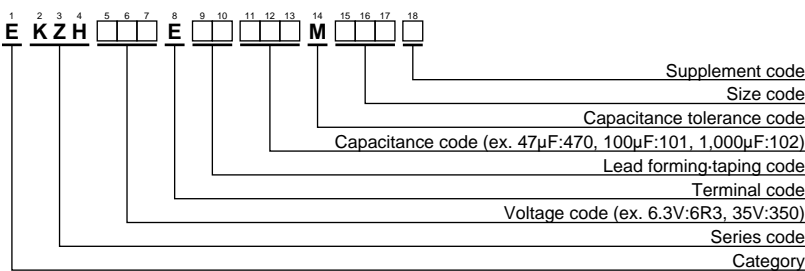

Please refer to "A guide to global code (radial lead type)"



### ◆STANDARD RATINGS

WV (Vdc)	Cap (μF)	Case size φD×L(mm)	Impedance (Ωmax/100kHz)		Rated ripple current (mA rms/105°C, 100kHz)	Part No.	WV (Vdc)	Cap (μF)	Case size φD×L(mm)	Impedance (Ωmax/100kHz)		Rated ripple current (mA rms/105°C, 100kHz)	Part No.	
			20°C	-10°C						20°C	-10°C			
6.3	220	5 × 11	0.24	0.80	330	EKZH6R3E□□221ME11D	16	1,800	10 × 25	0.018	0.054	2,250	EKZH160E□□182MJ25S	
	470	6.3 × 11	0.11	0.35	500	EKZH6R3E□□471MF11D		2,200	12.5 × 20	0.017	0.043	2,480	EKZH160E□□222MK20S	
	820	8 × 11.5	0.062	0.19	900	EKZH6R3E□□821MHB5D		2,700	12.5 × 25	0.015	0.038	2,900	EKZH160E□□272MK25S	
	1,200	8 × 15	0.048	0.15	1,210	EKZH6R3E□□122MH15D		3,300	12.5 × 30	0.013	0.033	3,450	EKZH160E□□332MK30S	
	1,200	10 × 12.5	0.045	0.14	1,240	EKZH6R3E□□122MJC5S		3,300	16 × 20	0.015	0.038	3,250	EKZH160E□□332ML20S	
	1,500	8 × 20	0.033	0.11	1,410	EKZH6R3E□□152MH20D		3,900	12.5 × 35	0.012	0.031	3,570	EKZH160E□□392MK35S	
	1,800	10 × 16	0.032	0.10	1,650	EKZH6R3E□□182MJ16S		4,700	16 × 25	0.013	0.035	3,630	EKZH160E□□472ML25S	
	2,200	10 × 20	0.020	0.060	1,960	EKZH6R3E□□222MJ20S		25	68	5 × 11	0.24	0.80	330	EKZH250E□□680ME11D
	2,700	10 × 25	0.018	0.054	2,250	EKZH6R3E□□272MJ25S			150	6.3 × 11	0.11	0.35	500	EKZH250E□□151MF11D
	3,900	12.5 × 20	0.017	0.043	2,480	EKZH6R3E□□392MK20S			330	8 × 11.5	0.062	0.19	900	EKZH250E□□331MHB5D
	4,700	12.5 × 25	0.015	0.038	2,900	EKZH6R3E□□472MK25S			390	8 × 15	0.048	0.15	1,210	EKZH250E□□391MH15D
	5,600	12.5 × 30	0.013	0.033	3,450	EKZH6R3E□□562MK30S			470	10 × 12.5	0.045	0.14	1,240	EKZH250E□□471MJC5S
	6,800	12.5 × 35	0.012	0.031	3,570	EKZH6R3E□□682MK35S			560	8 × 20	0.033	0.11	1,410	EKZH250E□□561MH20D
	6,800	16 × 20	0.015	0.038	3,250	EKZH6R3E□□682ML20S			680	10 × 16	0.032	0.10	1,650	EKZH250E□□681MJ16S
	8,200	16 × 25	0.013	0.035	3,630	EKZH6R3E□□822ML25S			820	10 × 20	0.020	0.060	1,960	EKZH250E□□821MJ20S
	10	150	5 × 11	0.24	0.80	330			EKZH100E□□151ME11D	1,000	10 × 25	0.018	0.054	2,250
330		6.3 × 11	0.11	0.35	500	EKZH100E□□331MF11D	1,500		12.5 × 20	0.017	0.043	2,480	EKZH250E□□152MK20S	
680		8 × 11.5	0.062	0.19	900	EKZH100E□□681MHB5D	1,800		12.5 × 25	0.015	0.038	2,900	EKZH250E□□182MK25S	
1,000		8 × 15	0.048	0.15	1,210	EKZH100E□□102MH15D	2,200		12.5 × 30	0.013	0.033	3,450	EKZH250E□□222MK30S	
1,000		10 × 12.5	0.045	0.14	1,240	EKZH100E□□102MJC5S	2,200		16 × 20	0.015	0.038	3,250	EKZH250E□□222ML20S	
1,500		8 × 20	0.033	0.11	1,410	EKZH100E□□152MH20D	2,700		12.5 × 35	0.012	0.031	3,570	EKZH250E□□272MK35S	
1,500		10 × 16	0.032	0.10	1,650	EKZH100E□□152MJ16S	3,300		16 × 25	0.013	0.035	3,630	EKZH250E□□332ML25S	
1,800		10 × 20	0.020	0.060	1,960	EKZH100E□□182MJ20S	35		47	5 × 11	0.24	0.80	330	EKZH350E□□470ME11D
2,200		10 × 25	0.018	0.054	2,250	EKZH100E□□222MJ25S		100	6.3 × 11	0.11	0.35	500	EKZH350E□□101MF11D	
3,300		12.5 × 20	0.017	0.043	2,480	EKZH100E□□332MK20S		220	8 × 11.5	0.062	0.19	900	EKZH350E□□221MHB5D	
3,900		12.5 × 25	0.015	0.038	2,900	EKZH100E□□392MK25S		270	8 × 15	0.048	0.15	1,210	EKZH350E□□271MH15D	
4,700		12.5 × 30	0.013	0.033	3,450	EKZH100E□□472MK30S		330	10 × 12.5	0.045	0.14	1,240	EKZH350E□□331MJC5S	
4,700		16 × 20	0.015	0.038	3,250	EKZH100E□□472ML20S		390	8 × 20	0.033	0.11	1,410	EKZH350E□□391MH20D	
5,600		12.5 × 35	0.012	0.031	3,570	EKZH100E□□562MK35S		470	10 × 16	0.032	0.10	1,650	EKZH350E□□471MJ16S	
6,800		16 × 25	0.013	0.035	3,630	EKZH100E□□682ML25S		560	10 × 20	0.020	0.060	1,960	EKZH350E□□561MJ20S	
16		100	5 × 11	0.24	0.80	330		EKZH160E□□101ME11D	680	10 × 25	0.018	0.054	2,250	EKZH350E□□681MJ25S
	220	6.3 × 11	0.11	0.35	500	EKZH160E□□221MF11D		1,000	12.5 × 20	0.017	0.043	2,480	EKZH350E□□102MK20S	
	470	8 × 11.5	0.062	0.19	900	EKZH160E□□471MHB5D		1,200	12.5 × 25	0.015	0.038	2,900	EKZH350E□□122MK25S	
	680	8 × 15	0.048	0.15	1,210	EKZH160E□□681MH15D		1,500	12.5 × 30	0.013	0.033	3,450	EKZH350E□□152MK30S	
	680	10 × 12.5	0.045	0.14	1,240	EKZH160E□□681MJC5S		1,500	16 × 20	0.015	0.038	3,250	EKZH350E□□152ML20S	
	1,000	8 × 20	0.033	0.11	1,410	EKZH160E□□102MH20D		1,800	12.5 × 35	0.012	0.031	3,570	EKZH350E□□182MK35S	
	1,000	10 × 16	0.032	0.10	1,650	EKZH160E□□102MJ16S		2,200	16 × 25	0.013	0.035	3,630	EKZH350E□□222ML25S	
	1,500	10 × 20	0.020	0.060	1,960	EKZH160E□□152MJ20S								

□ □ : Lead forming / Taping code

### ◆RATED RIPPLE CURRENT MULTIPLIERS

● Frequency Multipliers

Capacitance(μF)	Frequency (Hz)			
	120	1k	10k	100k
0.47 to 150	0.40	0.75	0.90	1.00
220 to 560	0.50	0.85	0.94	1.00
680 to 1,800	0.60	0.87	0.95	1.00
2,200 to 3,900	0.75	0.90	0.95	1.00
4,700 to 8,200	0.85	0.95	0.98	1.00

The endurance of capacitors is shortened with internal heating produced by ripple current at the rate of halving the lifetime with every 5°C rise. When long life performance is required in actual use, the rms ripple current has to be reduced.

# KZE Series

- Ultra Low impedance for Personal Computer and Storage Equipment
- Endurance with ripple current: 1,000 to 5,000 hours at 105°C
- Non solvent-proof type
- RoHS Compliant



## ◆ SPECIFICATIONS

Items	Characteristics
Category	
Temperature Range	-40 to +105°C
Rated Voltage Range	6.3 to 100V <sub>dc</sub>
Capacitance Tolerance	±20% (M) (at 20°C, 120Hz)
Leakage Current	I=0.01CV or 3μA, whichever is greater. Where, I : Max. leakage current (μA), C : Nominal capacitance (μF), V : Rated voltage (V) (at 20°C after 2 minutes)
Dissipation Factor (tanδ)	Rated voltage (V <sub>dc</sub> )
	tanδ (Max.)
Low Temperature Characteristics (Max. Impedance Ratio)	Z (-25°C) / Z (+20°C)
	Z (-40°C) / Z (+20°C)
Endurance	The following specifications shall be satisfied when the capacitors are restored to 20°C after subjected to DC voltage with the rated ripple current is applied for the specified period of time at 105°C.
	Time
	Capacitance change
	D.F. (tanδ)
	Leakage current
Shelf Life	The following specifications shall be satisfied when the capacitors are restored to 20°C after exposing them for 500 hours at 105°C without voltage applied.
	Capacitance change
	D.F. (tanδ)
	Leakage current

## ◆ DIMENSIONS [mm]

- Terminal Code : E

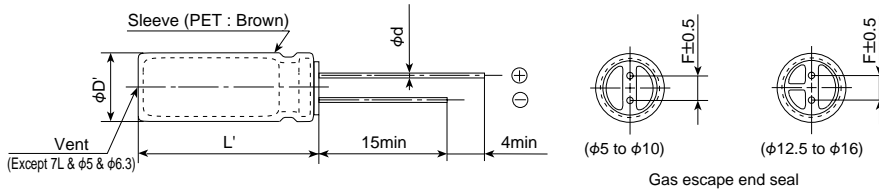

φD	5	6.3	8	10, 12.5	16, 18
φd	7L	0.45	0.45	0.45	—
	11L~	0.5	0.5	0.6	0.8
F	2.0	2.5	3.5	5.0	7.5
φD'	φD+0.5max.				
L'	L+1.5max.(7L : L+1.0max.)				

## ◆ PART NUMBERING SYSTEM

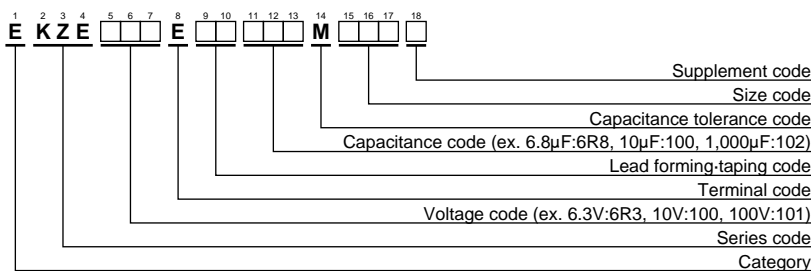

Please refer to "A guide to global code (radial lead type)"

◆STANDARD RATINGS

Table with 2 columns and multiple rows. Each column contains capacitor specifications including WV (Vdc), Cap (µF), Case size (φD×L(mm)), Impedance (Ωmax/100kHz) at 20°C and -10°C, Rated ripple current (mArms/105°C, 100kHz), and Part No. The rows are grouped by WV values: 6.3, 10, 16, and 25.

□ : Lead forming / Taping code

◆STANDARD RATINGS

WV (Vdc)	Cap (μF)	Case size φD×L(mm)	Impedance (Ωmax/100kHz)		Rated ripple current (mArms/ 105°C, 100kHz)	Part No.	WV (Vdc)	Cap (μF)	Case size φD×L(mm)	Impedance (Ωmax/100kHz)		Rated ripple current (mArms/ 105°C, 100kHz)	Part No.
			20°C	-10°C						20°C	-10°C		
63	1,200	18 × 31.5	0.020	0.060	3,300	EKZE630E□□122MMN3S	100	6.8	5 × 11	1.4	5.6	125	EKZE101E□□6R8ME11D
	1,500	18 × 35.5	0.018	0.054	3,400	EKZE630E□□152MMP1S		15	6.3 × 11	0.57	2.3	205	EKZE101E□□150MF11D
	1,800	18 × 40	0.017	0.051	3,500	EKZE630E□□182MM40S		27	8 × 11.5	0.36	1.4	355	EKZE101E□□270MHB5D
80	68	10 × 12.5	0.17	0.66	480	EKZE800E□□680MJC5S		39	8 × 15	0.25	1.0	450	EKZE101E□□390MH15D
	100	10 × 16	0.11	0.47	600	EKZE800E□□101MJ16S		47	10 × 12.5	0.17	0.66	480	EKZE101E□□470MJC5S
	120	10 × 20	0.084	0.34	800	EKZE800E□□121MJ20S		56	8 × 20	0.19	0.76	565	EKZE101E□□560MH20D
	150	10 × 25	0.069	0.28	900	EKZE800E□□151MJ25S		68	10 × 16	0.11	0.47	600	EKZE101E□□680MJ16S
	150	12.5 × 16	0.11	0.34	750	EKZE800E□□151MK16S		82	10 × 20	0.084	0.34	800	EKZE101E□□820MJ20S
	220	12.5 × 20	0.062	0.18	1,100	EKZE800E□□221MK20S		100	12.5 × 16	0.11	0.34	750	EKZE101E□□101MK16S
	330	12.5 × 25	0.047	0.14	1,250	EKZE800E□□331MK25S		120	10 × 25	0.069	0.28	900	EKZE101E□□121MJ25S
	330	16 × 20	0.048	0.15	1,350	EKZE800E□□331ML20S		150	12.5 × 20	0.062	0.18	1,100	EKZE101E□□151MK20S
	390	12.5 × 30	0.042	0.13	1,500	EKZE800E□□391MK30S		220	12.5 × 25	0.047	0.14	1,250	EKZE101E□□221MK25S
	470	12.5 × 35	0.036	0.11	1,650	EKZE800E□□471MK35S		220	16 × 20	0.048	0.15	1,350	EKZE101E□□221ML20S
	470	16 × 25	0.038	0.12	1,700	EKZE800E□□471ML25S		270	12.5 × 30	0.042	0.13	1,500	EKZE101E□□271MK30S
	470	18 × 20	0.045	0.14	1,500	EKZE800E□□471MM20S		330	12.5 × 35	0.036	0.11	1,650	EKZE101E□□331MK35S
	560	12.5 × 40	0.032	0.095	1,800	EKZE800E□□561MK40S		330	16 × 25	0.038	0.12	1,700	EKZE101E□□331ML25S
	680	16 × 31.5	0.032	0.095	1,850	EKZE800E□□681MLN3S		330	18 × 20	0.045	0.14	1,500	EKZE101E□□331MM20S
	680	18 × 25	0.036	0.11	1,750	EKZE800E□□681MM25S		390	12.5 × 40	0.032	0.095	1,800	EKZE101E□□391MK40S
	820	16 × 35.5	0.029	0.086	2,000	EKZE800E□□821MLP1S		470	16 × 31.5	0.032	0.095	1,850	EKZE101E□□471MLN3S
	820	18 × 31.5	0.030	0.090	1,900	EKZE800E□□821MMN3S		470	18 × 25	0.036	0.11	1,750	EKZE101E□□471MM25S
1,000	16 × 40	0.027	0.081	2,200	EKZE800E□□102ML40S	560		16 × 35.5	0.029	0.086	2,000	EKZE101E□□561MLP1S	
1,000	18 × 35.5	0.027	0.081	2,200	EKZE800E□□102MMP1S	560		18 × 31.5	0.030	0.090	1,900	EKZE101E□□561MMN3S	
1,200	18 × 40	0.026	0.077	2,700	EKZE800E□□122MM40S	680		16 × 40	0.027	0.081	2,200	EKZE101E□□681ML40S	
								680	18 × 35.5	0.027	0.081	2,200	EKZE101E□□681MMP1S
								820	18 × 40	0.026	0.077	2,700	EKZE101E□□821MM40S

□□ : Lead forming / Taping code

◆RATED RIPPLE CURRENT MULTIPLIERS

●Frequency Multipliers

7L

Capacitance(μF)	Frequency (Hz)			
	120	1k	10k	100k
10 to 33	0.42	0.70	0.90	1.00
39 to 220	0.50	0.73	0.92	1.00

11L to 40L

Capacitance(μF)	Frequency (Hz)			
	120	1k	10k	100k
6.8 to 180	0.40	0.75	0.90	1.00
220 to 560	0.50	0.85	0.94	1.00
680 to 1,800	0.60	0.87	0.95	1.00
2,200 to 3,900	0.75	0.90	0.95	1.00
4,700 to	0.85	0.95	0.98	1.00

The endurance of capacitors is shorted with internal heating produced by ripple current at the rate of halving the lifetime with every 5°C rise. When long life performance is required in actual use, the rms ripple current has to be reduced.

Upgrade!

**KY Series**

- Newly innovative electrolyte is employed to minimize ESR
- Endurance with ripple current : 4,000 to 10,000 hours at 105°C
- Non solvent-proof type
- 63 to 100V<sub>dc</sub> newly added
- RoHS Compliant

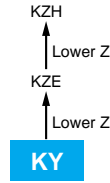

◆ SPECIFICATIONS

Items	Characteristics										
Category Temperature Range	-40 to +105°C										
Rated Voltage Range	6.3 to 100V <sub>dc</sub>										
Capacitance Tolerance	±20% (M) (at 20°C, 120Hz)										
Leakage Current	I=0.01CV or 3µA, whichever is greater. Where, I : Max. leakage current (µA), C : Nominal capacitance (µF), V : Rated voltage (V) (at 20°C after 2 minutes)										
Dissipation Factor (tanδ)	Rated voltage (V <sub>dc</sub> )	6.3V	10V	16V	25V	35V	50V	63V	80V	100V	
	tanδ (Max.)	0.22	0.19	0.16	0.14	0.12	0.10	0.09	0.09	0.08	
	When nominal capacitance exceeds 1,000µF, add 0.02 to the value above for each 1,000µF increase. (at 20°C, 120Hz)										
Low Temperature Characteristics (Max. Impedance Ratio)	Rated voltage (V <sub>dc</sub> )	6.3V	10V	16V	25V	35V	50V	63V	80V	100V	
	Z(-25°C)/Z(+20°C)	4	3	2	2	2	2	2	2	2	
	Z(-40°C)/Z(+20°C)	8	6	4	3	3	3	3	3	3	
Endurance	The following specifications shall be satisfied when the capacitors are restored to 20°C after subjected to DC voltage with the rated ripple current is applied for the specified period of time at 105°C.										
	Time	6.3 to 10V <sub>dc</sub>	φ5 & 6.3 : 4,000hours		φ8 & 10 : 6,000hours		φ12.5 to 18 : 8,000hours				
		16 to 50V <sub>dc</sub>	φ5 & 6.3 : 5,000hours		φ8 & 10 : 7,000hours		φ12.5 to 18 : 10,000hours				
	Capacitance change	≤±25% of the initial value									
	D.F. (tanδ)	≤200% of the initial specified value									
	Leakage current	≤The initial specified value									
Shelf Life	The following specifications shall be satisfied when the capacitors are restored to 20°C after exposing them for 500 hours at 105°C without voltage applied.										
	Capacitance change	≤±25% of the initial value									
	D.F. (tanδ)	≤200% of the initial specified value									
	Leakage current	≤The initial specified value									

◆ DIMENSIONS [mm]

● Terminal Code : E

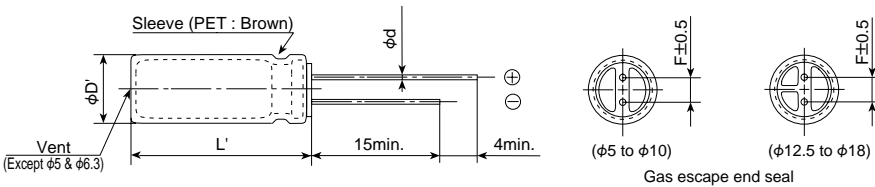

φD	5	6.3	8	10	12.5	16	18
φd	0.5	0.5	0.6	0.6	0.6	0.8	0.8
F	2.0	2.5	3.5	5.0	5.0	7.5	7.5
φD'	φD+0.5max.						
L'	L+1.5max.						

◆ PART NUMBERING SYSTEM

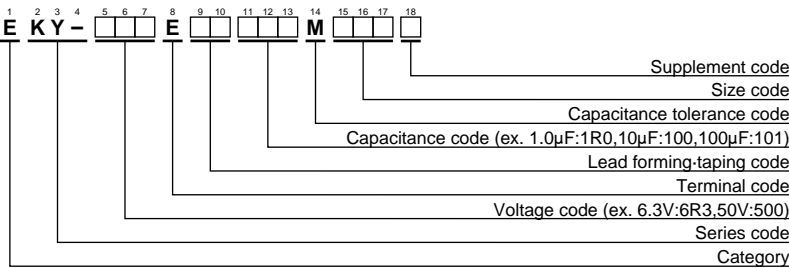

Please refer to "A guide to global code (radial lead type)"





# LXZ Series

- Newly innovative electrolyte and internal architecture are employed
- Very low impedance at high frequency range
- Endurance with ripple current: 2,000 to 8,000 hours at 105°C
- Solvent-proof type (see PRECAUTIONS AND GUIDELINES)
- RoHS Compliant

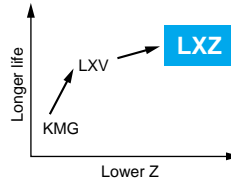

## ◆ SPECIFICATIONS

Items	Characteristics																								
Category Temperature Range	-55 to +105°C																								
Rated Voltage Range	6.3 to 63V <sub>dc</sub>																								
Capacitance Tolerance	±20% (M) (at 20°C, 120Hz)																								
Leakage Current	I=0.01CV or 3μA, whichever is greater. Where, I : Max. leakage current (μA), C : Nominal capacitance (μF), V : Rated voltage (V) (at 20°C after 2 minutes)																								
Dissipation Factor (tanδ)	<table border="1"> <tr> <td>Rated voltage (V<sub>dc</sub>)</td> <td>6.3V</td> <td>10V</td> <td>16V</td> <td>25V</td> <td>35V</td> <td>50V</td> <td>63V</td> </tr> <tr> <td>tanδ (Max.)</td> <td>0.22</td> <td>0.19</td> <td>0.16</td> <td>0.14</td> <td>0.12</td> <td>0.10</td> <td>0.08</td> </tr> </table> <p>When nominal capacitance exceeds 1,000μF, add 0.02 to the value above for each 1,000μF increase. (at 20°C, 120Hz)</p>	Rated voltage (V <sub>dc</sub> )	6.3V	10V	16V	25V	35V	50V	63V	tanδ (Max.)	0.22	0.19	0.16	0.14	0.12	0.10	0.08								
Rated voltage (V <sub>dc</sub> )	6.3V	10V	16V	25V	35V	50V	63V																		
tanδ (Max.)	0.22	0.19	0.16	0.14	0.12	0.10	0.08																		
Endurance	<p>The following specifications shall be satisfied when the capacitors are restored to 20°C after subjected to DC voltage with the rated ripple current is applied for the specified period of time at 105°C.</p> <table border="1"> <tr> <td>Time</td> <td>φ5 &amp; 6.3 : 2,000hours</td> <td>φ8 : 3,000hours</td> <td>φ10 : 5,000hours</td> <td>φ12.5 : 7,000hours</td> <td>φ16 &amp; 18 : 8,000hours</td> </tr> <tr> <td>Capacitance change</td> <td colspan="5">≤±20% of the initial value</td> </tr> <tr> <td>D.F. (tanδ)</td> <td colspan="5">≤200% of the initial specified value</td> </tr> <tr> <td>Leakage current</td> <td colspan="5">≤The initial specified value</td> </tr> </table>	Time	φ5 & 6.3 : 2,000hours	φ8 : 3,000hours	φ10 : 5,000hours	φ12.5 : 7,000hours	φ16 & 18 : 8,000hours	Capacitance change	≤±20% of the initial value					D.F. (tanδ)	≤200% of the initial specified value					Leakage current	≤The initial specified value				
Time	φ5 & 6.3 : 2,000hours	φ8 : 3,000hours	φ10 : 5,000hours	φ12.5 : 7,000hours	φ16 & 18 : 8,000hours																				
Capacitance change	≤±20% of the initial value																								
D.F. (tanδ)	≤200% of the initial specified value																								
Leakage current	≤The initial specified value																								
Shelf Life	<p>The following specifications shall be satisfied when the capacitors are restored to 20°C after exposing them for 1,000 hours at 105°C without voltage applied.</p> <table border="1"> <tr> <td>Capacitance change</td> <td>≤±20% of the initial value</td> </tr> <tr> <td>D.F. (tanδ)</td> <td>≤200% of the initial specified value</td> </tr> <tr> <td>Leakage current</td> <td>≤The initial specified value</td> </tr> </table>	Capacitance change	≤±20% of the initial value	D.F. (tanδ)	≤200% of the initial specified value	Leakage current	≤The initial specified value																		
Capacitance change	≤±20% of the initial value																								
D.F. (tanδ)	≤200% of the initial specified value																								
Leakage current	≤The initial specified value																								

## ◆ DIMENSIONS [mm]

- Terminal Code : E

Sleeve (PET : Dark blue)

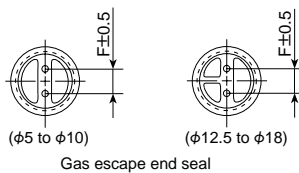
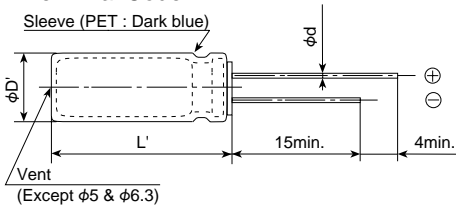

φD	5	6.3	8	10	12.5	16	18
φd	0.5	0.5	0.6	0.6	0.6	0.8	0.8
F	2.0	2.5	3.5	5.0	5.0	7.5	7.5
φD'	φD+0.5max.						
L'	L+1.5max.						

## ◆ PART NUMBERING SYSTEM

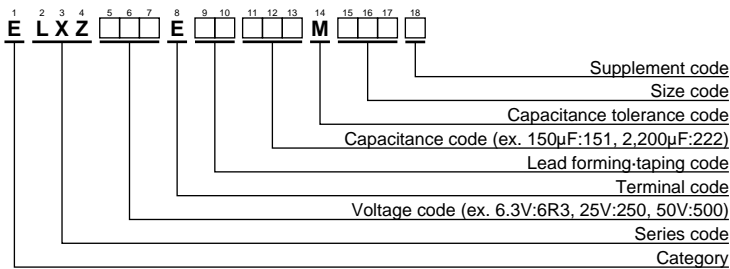

Please refer to "A guide to global code (radial lead type)"





### ◆STANDARD RATINGS

WV (Vdc)	Cap (μF)	Case size φD×L(mm)	Impedance (Ωmax/100kHz)		Rated ripple current (mA rms/105°C, 100kHz)	Part No.	WV (Vdc)	Cap (μF)	Case size φD×L(mm)	Impedance (Ωmax/100kHz)		Rated ripple current (mA rms/105°C, 100kHz)	Part No.	
			20°C	-10°C						20°C	-10°C			
6.3	150	5 × 11.5	0.50	1.0	175	ELXZ6R3E□□151MEB5D	16	3,300	12.5 × 35	0.022	0.044	2,510	ELXZ160E□□332MK35S	
	330	6.3 × 11.5	0.25	0.50	290	ELXZ6R3E□□331MFB5D		3,900	12.5 × 40	0.017	0.034	2,870	ELXZ160E□□392MK40S	
	470	6.3 × 15	0.18	0.36	400	ELXZ6R3E□□471MF15D		3,900	16 × 25	0.022	0.044	2,560	ELXZ160E□□392ML25S	
	680	8 × 12	0.12	0.24	555	ELXZ6R3E□□681MH12D		3,900	18 × 20	0.028	0.056	2,490	ELXZ160E□□392MM20S	
	820	10 × 12.5	0.090	0.18	760	ELXZ6R3E□□821MJC5S		4,700	16 × 30	0.019	0.038	3,010	ELXZ160E□□472ML30S	
	1,000	8 × 15	0.090	0.18	730	ELXZ6R3E□□102MH15D		4,700	18 × 25	0.020	0.040	2,740	ELXZ160E□□472MM25S	
	1,200	8 × 20	0.080	0.16	810	ELXZ6R3E□□122MH20D		5,600	16 × 35	0.017	0.034	3,150	ELXZ160E□□562ML35S	
	1,200	10 × 16	0.068	0.136	1,050	ELXZ6R3E□□122MJ16S		5,600	18 × 30	0.018	0.036	3,330	ELXZ160E□□562MM30S	
	1,500	10 × 20	0.052	0.104	1,220	ELXZ6R3E□□152MJ20S		6,800	16 × 40	0.015	0.030	3,710	ELXZ160E□□682ML40S	
	2,200	10 × 25	0.045	0.090	1,440	ELXZ6R3E□□222MJ25S		8,200	18 × 35	0.016	0.032	3,680	ELXZ160E□□822MM35S	
	2,700	10 × 30	0.037	0.074	1,690	ELXZ6R3E□□272MJ30S		10,000	18 × 40	0.015	0.030	3,800	ELXZ160E□□103MM40S	
	3,300	12.5 × 20	0.038	0.076	1,660	ELXZ6R3E□□332MK20S		25	47	5 × 11.5	0.50	1.0	175	ELXZ250E□□470MEB5D
	3,900	12.5 × 25	0.030	0.060	1,950	ELXZ6R3E□□392MK25S			100	6.3 × 11.5	0.25	0.50	290	ELXZ250E□□101MFB5D
	4,700	12.5 × 30	0.025	0.050	2,310	ELXZ6R3E□□472MK30S			150	6.3 × 15	0.18	0.36	400	ELXZ250E□□151MF15D
	5,600	12.5 × 35	0.022	0.044	2,510	ELXZ6R3E□□562MK35S			220	8 × 12	0.12	0.24	555	ELXZ250E□□221MH12D
	5,600	16 × 20	0.029	0.058	2,210	ELXZ6R3E□□562ML20S			330	8 × 15	0.090	0.18	730	ELXZ250E□□331MH15D
	6,800	12.5 × 40	0.017	0.034	2,870	ELXZ6R3E□□682MK40S			330	10 × 12.5	0.090	0.18	760	ELXZ250E□□331MJC5S
	6,800	16 × 25	0.022	0.044	2,560	ELXZ6R3E□□682ML25S			390	8 × 20	0.080	0.16	810	ELXZ250E□□391MH20D
6,800	18 × 20	0.028	0.056	2,490	ELXZ6R3E□□682MM20S	470	10 × 16		0.068	0.136	1,050	ELXZ250E□□471MJ16S		
8,200	16 × 30	0.019	0.038	3,010	ELXZ6R3E□□822ML30S	680	10 × 20		0.052	0.104	1,220	ELXZ250E□□681MJ20S		
10,000	16 × 35	0.017	0.034	3,150	ELXZ6R3E□□103ML35S	820	10 × 25		0.045	0.090	1,440	ELXZ250E□□821MJ25S		
10,000	18 × 25	0.020	0.040	2,740	ELXZ6R3E□□103MM25S	1,000	10 × 30		0.037	0.074	1,690	ELXZ250E□□102MJ30S		
12,000	16 × 40	0.015	0.030	3,710	ELXZ6R3E□□123ML40S	1,000	12.5 × 20		0.038	0.076	1,660	ELXZ250E□□102MK20S		
12,000	18 × 30	0.018	0.036	3,330	ELXZ6R3E□□123MM30S	1,500	12.5 × 25		0.030	0.060	1,950	ELXZ250E□□152MK25S		
15,000	18 × 35	0.016	0.032	3,680	ELXZ6R3E□□153MM35S	1,800	12.5 × 30		0.025	0.050	2,310	ELXZ250E□□182MK30S		
18,000	18 × 40	0.015	0.030	3,800	ELXZ6R3E□□183MM40S	1,800	16 × 20		0.029	0.058	2,210	ELXZ250E□□182ML20S		
10	100	5 × 11.5	0.50	1.0	175	ELXZ100E□□101MEB5D	2,200		12.5 × 35	0.022	0.044	2,510	ELXZ250E□□222MK35S	
	220	6.3 × 11.5	0.25	0.50	290	ELXZ100E□□221MFB5D	2,200		18 × 20	0.028	0.056	2,490	ELXZ250E□□222MM20S	
	330	6.3 × 15	0.18	0.36	400	ELXZ100E□□331MF15D	2,700		12.5 × 40	0.017	0.034	2,870	ELXZ250E□□272MK40S	
	470	8 × 12	0.12	0.24	555	ELXZ100E□□471MH12D	2,700	16 × 25	0.022	0.044	2,560	ELXZ250E□□272ML25S		
	680	8 × 15	0.090	0.18	730	ELXZ100E□□681MH15D	3,300	16 × 30	0.019	0.038	3,010	ELXZ250E□□332ML30S		
	680	10 × 12.5	0.090	0.18	760	ELXZ100E□□681MJC5S	3,300	18 × 25	0.020	0.040	2,740	ELXZ250E□□332MM25S		
	1,000	8 × 20	0.080	0.16	810	ELXZ100E□□102MH20D	3,900	16 × 35	0.017	0.034	3,150	ELXZ250E□□392ML35S		
	1,000	10 × 16	0.068	0.136	1,050	ELXZ100E□□102MJ16S	3,900	18 × 30	0.018	0.036	3,330	ELXZ250E□□392MM30S		
	1,200	10 × 20	0.052	0.104	1,220	ELXZ100E□□122MJ20S	4,700	16 × 40	0.015	0.030	3,710	ELXZ250E□□472ML40S		
	1,500	10 × 25	0.045	0.090	1,440	ELXZ100E□□152MJ25S	4,700	18 × 35	0.016	0.032	3,680	ELXZ250E□□472MM35S		
	1,800	10 × 30	0.037	0.074	1,690	ELXZ100E□□182MJ30S	5,600	18 × 40	0.015	0.030	3,800	ELXZ250E□□562MM40S		
	2,200	12.5 × 20	0.038	0.076	1,660	ELXZ100E□□222MK20S	35	33	5 × 11.5	0.50	1.0	175	ELXZ350E□□330MEB5D	
	3,300	12.5 × 25	0.030	0.060	1,950	ELXZ100E□□332MK25S		56	6.3 × 11.5	0.25	0.50	290	ELXZ350E□□560MFB5D	
	3,900	12.5 × 30	0.025	0.050	2,310	ELXZ100E□□392MK30S		100	6.3 × 15	0.18	0.36	400	ELXZ350E□□101MF15D	
	3,900	16 × 20	0.029	0.058	2,210	ELXZ100E□□392ML20S		150	8 × 12	0.12	0.24	555	ELXZ350E□□151MH12D	
	4,700	12.5 × 35	0.022	0.044	2,510	ELXZ100E□□472MK35S		220	8 × 15	0.090	0.18	730	ELXZ350E□□221MH15D	
	5,600	12.5 × 40	0.017	0.034	2,870	ELXZ100E□□562MK40S		220	10 × 12.5	0.090	0.18	760	ELXZ350E□□221MJC5S	
	5,600	16 × 25	0.022	0.044	2,560	ELXZ100E□□562ML25S		270	8 × 20	0.080	0.16	810	ELXZ350E□□271MH20D	
5,600	18 × 20	0.028	0.056	2,490	ELXZ100E□□562MM20S	330		10 × 16	0.068	0.136	1,050	ELXZ350E□□331MJ16S		
6,800	16 × 30	0.019	0.038	3,010	ELXZ100E□□682ML30S	470		10 × 20	0.052	0.104	1,220	ELXZ350E□□471MJ20S		
6,800	18 × 25	0.020	0.040	2,740	ELXZ100E□□682MM25S	560		10 × 25	0.045	0.090	1,440	ELXZ350E□□561MJ25S		
8,200	16 × 35	0.017	0.034	3,150	ELXZ100E□□822ML35S	680		10 × 30	0.037	0.074	1,690	ELXZ350E□□681MJ30S		
8,200	18 × 30	0.018	0.036	3,330	ELXZ100E□□822MM30S	680		12.5 × 20	0.038	0.076	1,660	ELXZ350E□□681MK20S		
10,000	16 × 40	0.015	0.030	3,710	ELXZ100E□□103ML40S	1,000		12.5 × 25	0.030	0.060	1,950	ELXZ350E□□102MK25S		
10,000	18 × 35	0.016	0.032	3,680	ELXZ100E□□103MM35S	1,200		12.5 × 30	0.025	0.050	2,310	ELXZ350E□□122MK30S		
12,000	18 × 40	0.015	0.030	3,800	ELXZ100E□□123MM40S	1,200		16 × 20	0.029	0.058	2,210	ELXZ350E□□122ML20S		
16	47	5 × 11.5	0.50	1.0	175	ELXZ160E□□470MEB5D		1,500	12.5 × 35	0.022	0.044	2,510	ELXZ350E□□152MK35S	
	100	6.3 × 11.5	0.25	0.50	290	ELXZ160E□□101MFB5D		1,800	12.5 × 40	0.017	0.034	2,870	ELXZ350E□□182MK40S	
	220	6.3 × 15	0.18	0.36	400	ELXZ160E□□221MF15D		1,800	16 × 25	0.022	0.044	2,560	ELXZ350E□□182ML25S	
	330	8 × 12	0.12	0.24	555	ELXZ160E□□331MH12D	1,800	18 × 20	0.028	0.056	2,490	ELXZ350E□□182MM20S		
	470	8 × 15	0.090	0.18	730	ELXZ160E□□471MH15D	2,200	16 × 30	0.019	0.038	3,010	ELXZ350E□□222ML30S		
	470	10 × 12.5	0.090	0.18	760	ELXZ160E□□471MJC5S	2,200	18 × 25	0.020	0.040	2,740	ELXZ350E□□222MM25S		
	560	8 × 20	0.080	0.16	810	ELXZ160E□□561MH20D	2,700	16 × 35	0.017	0.034	3,150	ELXZ350E□□272ML35S		
	680	10 × 16	0.068	0.136	1,050	ELXZ160E□□681MJ16S	2,700	18 × 30	0.018	0.036	3,330	ELXZ350E□□272MM30S		
	1,000	10 × 20	0.052	0.104	1,220	ELXZ160E□□102MJ20S	3,300	16 × 40	0.015	0.030	3,710	ELXZ350E□□332ML40S		
	1,200	10 × 25	0.045	0.090	1,440	ELXZ160E□□122MJ25S	3,300	18 × 35	0.016	0.032	3,680	ELXZ350E□□332MM35S		
	1,500	10 × 30	0.037	0.074	1,690	ELXZ160E□□152MJ30S	3,900	18 × 40	0.015	0.030	3,800	ELXZ350E□□392MM40S		
	1,500	12.5 × 20	0.038	0.076	1,660	ELXZ160E□□152MK20S	50	22	5 × 11.5	0.90	1.8	155	ELXZ500E□□220MEB5D	
	2,200	12.5 × 25	0.030	0.060	1,950	ELXZ160E□□222MK25S		47	6.3 × 11.5	0.45	0.90	260	ELXZ500E□□470MFB5D	
	2,700	12.5 × 30	0.025	0.050	2,310	ELXZ160E□□272MK30S		68	6.3 × 15	0.31	0.62	360	ELXZ500E□□680MF15D	
	2,700	16 × 20	0.029	0.058	2,210	ELXZ160E□□272ML20S		100	8 × 12	0.22	0.44	485	ELXZ500E□□101MH12D	

□ : Lead forming / Taping code

## ◆STANDARD RATINGS

WV (Vdc)	Cap (μF)	Case size φD×L(mm)	Impedance (Ωmax/100kHz)		Rated ripple current (mA <sub>rms</sub> /105°C, 100kHz)	Part No.	WV (Vdc)	Cap (μF)	Case size φD×L(mm)	Impedance (Ωmax/100kHz)		Rated ripple current (mA <sub>rms</sub> /105°C, 100kHz)	Part No.
			20°C	-10°C						20°C	-10°C		
50	120	8 × 15	0.16	0.32	635	ELXZ500E□□121MH15D	63	39	6.3 × 15	0.61	1.4	330	ELXZ630E□□390MF15D
	120	10 × 12.5	0.16	0.32	620	ELXZ500E□□121MJC5S		68	8 × 12	0.34	0.75	405	ELXZ630E□□680MH12D
	180	8 × 20	0.12	0.24	730	ELXZ500E□□181MH20D		100	8 × 15	0.27	0.65	535	ELXZ630E□□101MH15D
	180	10 × 16	0.13	0.26	850	ELXZ500E□□181MJ16S		100	10 × 12.5	0.255	0.51	540	ELXZ630E□□101MJC5S
	220	10 × 20	0.088	0.18	1,050	ELXZ500E□□221MJ20S		120	10 × 16	0.19	0.38	600	ELXZ630E□□121MJ16S
	330	10 × 25	0.073	0.15	1,250	ELXZ500E□□331MJ25S		150	8 × 20	0.21	0.52	690	ELXZ630E□□151MH20D
	390	10 × 30	0.054	0.11	1,500	ELXZ500E□□391MJ30S		180	10 × 20	0.145	0.29	890	ELXZ630E□□181MJ20S
	390	12.5 × 20	0.059	0.12	1,480	ELXZ500E□□391MK20S		220	10 × 25	0.13	0.26	1,050	ELXZ630E□□221MJ25S
	560	12.5 × 25	0.044	0.088	1,840	ELXZ500E□□561MK25S		330	10 × 30	0.090	0.18	1,300	ELXZ630E□□331MJ30S
	680	12.5 × 30	0.039	0.078	2,220	ELXZ500E□□681MK30S		330	12.5 × 20	0.085	0.17	1,290	ELXZ630E□□331MK20S
	680	16 × 20	0.048	0.096	1,840	ELXZ500E□□681ML20S		390	12.5 × 25	0.070	0.14	1,720	ELXZ630E□□391MK25S
	820	12.5 × 35	0.033	0.066	2,290	ELXZ500E□□821MK35S		470	12.5 × 30	0.055	0.11	2,090	ELXZ630E□□471MK30S
	820	18 × 20	0.042	0.084	1,980	ELXZ500E□□821MM20S		470	16 × 20	0.059	0.12	1,770	ELXZ630E□□471ML20S
	1,000	12.5 × 40	0.029	0.058	2,500	ELXZ500E□□102MK40S		680	12.5 × 35	0.047	0.094	2,270	ELXZ630E□□681MK35S
	1,000	16 × 25	0.034	0.068	2,240	ELXZ500E□□102ML25S		680	16 × 25	0.050	0.10	2,160	ELXZ630E□□681ML25S
	1,200	16 × 30	0.028	0.056	2,700	ELXZ500E□□122ML30S		680	18 × 20	0.055	0.11	2,290	ELXZ630E□□681MM20S
	1,200	18 × 25	0.029	0.058	2,610	ELXZ500E□□122MM25S		820	12.5 × 40	0.042	0.084	2,560	ELXZ630E□□821MK40S
	1,500	16 × 35	0.025	0.050	2,800	ELXZ500E□□152ML35S		820	16 × 30	0.043	0.086	2,670	ELXZ630E□□821ML30S
	1,800	16 × 40	0.021	0.042	3,200	ELXZ500E□□182ML40S		820	18 × 25	0.043	0.086	2,590	ELXZ630E□□821MM25S
	1,800	18 × 30	0.025	0.050	3,000	ELXZ500E□□182MM30S		1,000	16 × 35	0.036	0.072	2,770	ELXZ630E□□102ML35S
2,200	18 × 35	0.023	0.046	3,100	ELXZ500E□□222MM35S	1,200	16 × 40	0.030	0.060	2,850	ELXZ630E□□122ML40S		
2,700	18 × 40	0.020	0.040	3,400	ELXZ500E□□272MM40S	1,200	18 × 30	0.032	0.064	2,950	ELXZ630E□□122MM30S		
63	12	5 × 11.5	1.9	4.0	145	ELXZ630E□□120MEB5D	1,500	18 × 35	0.030	0.060	3,100	ELXZ630E□□152MM35S	
	22	6.3 × 11.5	1.0	2.0	240	ELXZ630E□□220MFB5D	1,800	18 × 40	0.025	0.050	3,210	ELXZ630E□□182MM40S	

□□ : Lead forming / Taping code

## ◆RATED RIPPLE CURRENT MULTIPLIERS

### ●Frequency Multipliers

Capacitance (μF)	Frequency (Hz)			
	120	1k	10k	100k
12 to 180	0.40	0.75	0.90	1.00
220 to 560	0.50	0.85	0.94	1.00
680 to 1,800	0.60	0.87	0.95	1.00
2,200 to 3,900	0.75	0.90	0.95	1.00
4,700 to 18,000	0.85	0.95	0.98	1.00

The endurance of capacitors is shorted with internal heating produced by ripple current at the rate of halving the lifetime with every 5°C rise. When long life performance is required in actual use, the rms ripple current has to be reduced.



## LXY Series

- Newly innovative electrolyte and internal architecture are employed
- Endurance with ripple current : 2,000 to 8,000 hours at 105°C
- Solvent-proof type (see PRECAUTIONS AND GUIDELINES)
- RoHS Compliant

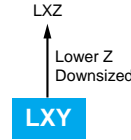

### SPECIFICATIONS

Items	Characteristics	
Category	-55 to +105°C	
Temperature Range	-55 to +105°C	
Rated Voltage Range	10 to 63V <sub>dc</sub>	
Capacitance Tolerance	±20% (M) (at 20°C, 120Hz)	
Leakage Current	I=0.01CV or 3μA, whichever is greater. Where, I : Max. leakage current (μA), C : Nominal capacitance (μF), V : Rated voltage (V) (at 20°C after 2 minutes)	
Dissipation Factor (tanδ)	Rated voltage (V <sub>dc</sub> )	10V 16V 25V 35V 50V 63V
	tanδ (Max.)	0.19 0.16 0.14 0.12 0.10 0.10
	When nominal capacitance exceeds 1,000μF, add 0.02 to the value above for each 1,000μF increase. (at 20°C, 120Hz)	
Low Temperature Characteristics (Max. Impedance Ratio)	Z(-55°C)/Z(+20°C)	10V <sub>dc</sub> to 50V <sub>dc</sub> : 3max. 63V <sub>dc</sub> : 6max. (at 120Hz)
	Endurance	
The following specifications shall be satisfied when the capacitors are restored to 20°C after subjected to DC voltage with the rated ripple current is applied for the specified period of time at 105°C.		
Time	φ5 & 6.3 : 2,000hours φ8 : 3,000hours φ10 : 5,000hours φ12.5 : 7,000hours φ16 & 18 : 8,000hours	
Capacitance change	≤±20% of the initial value	
D.F. (tanδ)	≤200% of the initial specified value	
Leakage current	≤The initial specified value	
Shelf Life	The following specifications shall be satisfied when the capacitors are restored to 20°C after exposing them for 1,000 hours at 105°C without voltage applied.	
	Capacitance change	≤±20% of the initial value
	D.F. (tanδ)	≤200% of the initial specified value
	Leakage current	≤The initial specified value

### DIMENSIONS [mm]

- Terminal Code : E

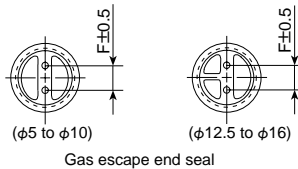
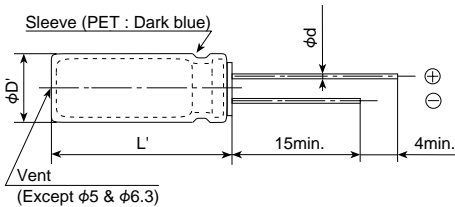

φD	5	6.3	8	10	12.5	16
φd	0.5	0.5	0.6	0.6	0.6	0.8
F	2.0	2.5	3.5	5.0	5.0	7.5
φD'	φD+0.5max.					
L'	L+1.5max.					

### PART NUMBERING SYSTEM

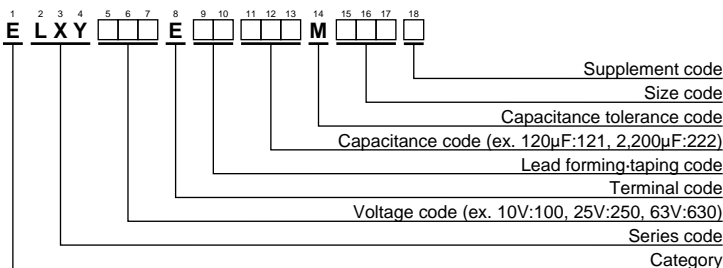

Please refer to "A guide to global code (radial lead type)"

### RATED RIPPLE CURRENT MULTIPLIERS

- Frequency Multipliers

Capacitance (μF)	Frequency (Hz)	120	1k	10k	100k
10 to 180		0.40	0.75	0.90	1.00
220 to 560		0.50	0.85	0.94	1.00
680 to 1,800		0.60	0.87	0.95	1.00
2,200 to 3,900		0.75	0.90	0.95	1.00
4,700 to 8,200		0.85	0.95	0.98	1.00

The endurance of capacitors is shortened with internal heating produced by ripple current at the rate of halving the lifetime with every 5°C rise. When long life performance is required in actual use, the rms ripple current has to be reduced.

## ◆STANDARD RATINGS

WV (Vdc)	Cap (μF)	Case size φD×L(mm)	Impedance (Ωmax/100kHz)		Rated ripple current (mA rms/105°C, 100kHz)	Part No.	WV (Vdc)	Cap (μF)	Case size φD×L(mm)	Impedance (Ωmax/100kHz)		Rated ripple current (mA rms/105°C, 100kHz)	Part No.
			20°C	-10°C						20°C	-10°C		
10	82	5 × 11.5	0.75	1.5	163	ELXY100E□□820MEB5D	35	27	5 × 11.5	0.75	1.5	163	ELXY350E□□270MEB5D
	180	6.3 × 11.5	0.35	0.70	273	ELXY100E□□181MFB5D		56	6.3 × 11.5	0.35	0.70	273	ELXY350E□□560MFB5D
	220	6.3 × 15	0.25	0.50	390	ELXY100E□□221MF15D		82	6.3 × 15	0.25	0.50	390	ELXY350E□□820MF15D
	330	8 × 12	0.17	0.34	445	ELXY100E□□331MH12D		120	8 × 12	0.17	0.34	445	ELXY350E□□121MH12D
	390	10 × 12.5	0.12	0.24	625	ELXY100E□□391MJC5S		120	10 × 12.5	0.12	0.24	625	ELXY350E□□121MJC5S
	470	8 × 15	0.13	0.26	555	ELXY100E□□471MH15D		180	8 × 15	0.13	0.26	555	ELXY350E□□181MH15D
	680	8 × 20	0.095	0.19	740	ELXY100E□□681MH20D		220	8 × 20	0.095	0.19	740	ELXY350E□□221MH20D
	680	10 × 16	0.084	0.17	825	ELXY100E□□681MJ16S		220	10 × 16	0.084	0.17	825	ELXY350E□□221MJ16S
	1,000	10 × 20	0.062	0.13	1,040	ELXY100E□□102MJ20S		330	10 × 20	0.062	0.13	1,040	ELXY350E□□331MJ20S
	1,200	10 × 25	0.052	0.11	1,260	ELXY100E□□122MJ25S		390	10 × 25	0.052	0.11	1,260	ELXY350E□□391MJ25S
	1,500	10 × 30	0.044	0.088	1,440	ELXY100E□□152MJ30S		560	10 × 30	0.044	0.088	1,440	ELXY350E□□561MJ30S
	1,800	12.5 × 20	0.046	0.092	1,340	ELXY100E□□182MK20S		560	12.5 × 20	0.046	0.092	1,340	ELXY350E□□561MK20S
	2,200	12.5 × 25	0.034	0.068	1,690	ELXY100E□□222MK25S		680	12.5 × 25	0.034	0.068	1,690	ELXY350E□□681MK25S
	2,700	12.5 × 30	0.030	0.060	1,950	ELXY100E□□272MK30S		1,000	12.5 × 30	0.030	0.060	1,950	ELXY350E□□102MK30S
	3,300	12.5 × 35	0.024	0.048	2,220	ELXY100E□□332MK35S		1,000	16 × 20	0.038	0.076	1,630	ELXY350E□□102ML20S
	3,300	16 × 20	0.038	0.076	1,630	ELXY100E□□332ML20S		1,200	12.5 × 35	0.024	0.048	2,220	ELXY350E□□122MK35S
	3,900	12.5 × 40	0.022	0.044	2,390	ELXY100E□□392MK40S		1,200	16 × 25	0.028	0.056	2,070	ELXY350E□□122ML25S
	3,900	16 × 25	0.028	0.056	2,070	ELXY100E□□392ML25S		1,500	12.5 × 40	0.022	0.044	2,390	ELXY350E□□152MK40S
5,600	16 × 30	0.025	0.050	2,350	ELXY100E□□562ML30S	1,800	16 × 30	0.025	0.050	2,350	ELXY350E□□182ML30S		
6,800	16 × 35	0.022	0.044	2,550	ELXY100E□□682ML35S	2,200	16 × 35	0.022	0.044	2,550	ELXY350E□□222ML35S		
8,200	16 × 40	0.018	0.036	2,900	ELXY100E□□822ML40S	2,700	16 × 40	0.018	0.036	2,900	ELXY350E□□272ML40S		
16	56	5 × 11.5	0.75	1.5	163	ELXY160E□□560MEB5D	50	18	5 × 11.5	1.2	2.4	129	ELXY500E□□180MEB5D
	120	6.3 × 11.5	0.35	0.70	273	ELXY160E□□121MFB5D		39	6.3 × 11.5	0.54	1.1	219	ELXY500E□□390MFB5D
	180	6.3 × 15	0.25	0.50	390	ELXY160E□□181MF15D		56	6.3 × 15	0.34	0.68	310	ELXY500E□□560MF15D
	270	8 × 12	0.17	0.34	445	ELXY160E□□271MH12D		68	8 × 12	0.30	0.60	340	ELXY500E□□680MH12D
	270	10 × 12.5	0.12	0.24	625	ELXY160E□□271MJC5S		82	8 × 15	0.20	0.40	470	ELXY500E□□820MH15D
	330	8 × 15	0.13	0.26	555	ELXY160E□□331MH15D		82	10 × 12.5	0.20	0.40	480	ELXY500E□□820MJC5S
	470	8 × 20	0.095	0.19	740	ELXY160E□□471MH20D		120	8 × 20	0.14	0.28	610	ELXY500E□□121MH20D
	470	10 × 16	0.084	0.17	825	ELXY160E□□471MJ16S		120	10 × 16	0.13	0.26	755	ELXY500E□□121MJ16S
	680	10 × 20	0.062	0.13	1,040	ELXY160E□□681MJ20S		180	10 × 20	0.088	0.18	945	ELXY500E□□181MJ20S
	820	10 × 25	0.052	0.11	1,260	ELXY160E□□821MJ25S		220	10 × 25	0.073	0.15	1,150	ELXY500E□□221MJ25S
	1,200	10 × 30	0.044	0.088	1,440	ELXY160E□□122MJ30S		330	10 × 30	0.054	0.11	1,260	ELXY500E□□331MJ30S
	1,200	12.5 × 20	0.046	0.092	1,340	ELXY160E□□122MK20S		330	12.5 × 20	0.059	0.12	1,190	ELXY500E□□331MK20S
	1,500	12.5 × 25	0.034	0.068	1,690	ELXY160E□□152MK25S		470	12.5 × 25	0.044	0.088	1,490	ELXY500E□□471MK25S
	2,200	12.5 × 30	0.030	0.060	1,950	ELXY160E□□222MK30S		560	12.5 × 30	0.039	0.078	1,720	ELXY500E□□561MK30S
	2,200	16 × 20	0.038	0.076	1,630	ELXY160E□□222ML20S		680	12.5 × 35	0.033	0.066	1,890	ELXY500E□□681MK35S
	2,700	12.5 × 35	0.024	0.048	2,220	ELXY160E□□272MK35S		680	16 × 20	0.050	0.10	1,420	ELXY500E□□681ML20S
	2,700	16 × 25	0.028	0.056	2,070	ELXY160E□□272ML25S		820	12.5 × 40	0.029	0.058	2,030	ELXY500E□□821MK40S
	3,300	12.5 × 40	0.022	0.044	2,390	ELXY160E□□332MK40S		820	16 × 25	0.034	0.068	1,880	ELXY500E□□821ML25S
3,900	16 × 30	0.025	0.050	2,350	ELXY160E□□392ML30S	1,000	16 × 30	0.030	0.060	2,150	ELXY500E□□102ML30S		
4,700	16 × 35	0.022	0.044	2,550	ELXY160E□□472ML35S	1,200	16 × 35	0.027	0.054	2,320	ELXY500E□□122ML35S		
5,600	16 × 40	0.018	0.036	2,900	ELXY160E□□562ML40S	1,500	16 × 40	0.024	0.048	2,540	ELXY500E□□152ML40S		
25	39	5 × 11.5	0.75	1.5	163	ELXY250E□□390MEB5D	63	10	5 × 11.5	1.9	4.8	103	ELXY630E□□100MEB5D
	82	6.3 × 11.5	0.35	0.70	273	ELXY250E□□820MFB5D		18	6.3 × 11.5	1.0	2.5	161	ELXY630E□□180MFB5D
	120	6.3 × 15	0.25	0.50	390	ELXY250E□□121MF15D		33	6.3 × 15	0.61	1.6	233	ELXY630E□□330MF15D
	150	8 × 12	0.17	0.34	445	ELXY250E□□151MH12D		47	8 × 12	0.47	1.2	274	ELXY630E□□470MH12D
	180	10 × 12.5	0.12	0.24	625	ELXY250E□□181MJC5S		56	10 × 12.5	0.27	0.68	418	ELXY630E□□560MJC5S
	220	8 × 15	0.13	0.26	555	ELXY250E□□221MH15D		68	8 × 15	0.34	0.85	360	ELXY630E□□680MH15D
	330	8 × 20	0.095	0.19	740	ELXY250E□□331MH20D		68	10 × 16	0.21	0.53	525	ELXY630E□□680MJ16S
	330	10 × 16	0.084	0.17	825	ELXY250E□□331MJ16S		82	8 × 20	0.21	0.53	500	ELXY630E□□820MH20D
	470	10 × 20	0.062	0.13	1,040	ELXY250E□□471MJ20S		120	10 × 20	0.16	0.40	650	ELXY630E□□121MJ20S
	560	10 × 25	0.052	0.11	1,260	ELXY250E□□561MJ25S		150	10 × 25	0.13	0.33	783	ELXY630E□□151MJ25S
	820	10 × 30	0.044	0.088	1,440	ELXY250E□□821MJ30S		180	10 × 30	0.10	0.25	960	ELXY630E□□181MJ30S
	820	12.5 × 20	0.046	0.092	1,340	ELXY250E□□821MK20S		220	12.5 × 20	0.11	0.28	870	ELXY630E□□221MK20S
	1,000	12.5 × 25	0.034	0.068	1,690	ELXY250E□□102MK25S		270	12.5 × 25	0.074	0.19	1,150	ELXY630E□□271MK25S
	1,500	12.5 × 30	0.030	0.060	1,950	ELXY250E□□152MK30S		330	16 × 20	0.085	0.22	1,100	ELXY630E□□331ML20S
	1,500	16 × 20	0.038	0.076	1,630	ELXY250E□□152ML20S		390	12.5 × 30	0.068	0.17	1,280	ELXY630E□□391MK30S
	1,800	12.5 × 35	0.024	0.048	2,220	ELXY250E□□182MK35S		470	12.5 × 35	0.063	0.16	1,390	ELXY630E□□471MK35S
	1,800	16 × 25	0.028	0.056	2,070	ELXY250E□□182ML25S		470	16 × 25	0.055	0.14	1,480	ELXY630E□□471ML25S
	2,200	12.5 × 40	0.022	0.044	2,390	ELXY250E□□222MK40S		560	12.5 × 40	0.051	0.13	1,530	ELXY630E□□561MK40S
2,700	16 × 30	0.025	0.050	2,350	ELXY250E□□272ML30S	680	16 × 30	0.046	0.12	1,720	ELXY630E□□681ML30S		
3,300	16 × 35	0.022	0.044	2,550	ELXY250E□□332ML35S	820	16 × 35	0.040	0.10	1,910	ELXY630E□□821ML35S		
3,900	16 × 40	0.018	0.036	2,900	ELXY250E□□392ML40S	1,000	16 × 40	0.036	0.09	2,070	ELXY630E□□102ML40S		

□□ : Lead forming / Taping code

**LXV Series**

- Low impedance
- Endurance with ripple current : 2,000 to 5,000 hours at 105°C
- Solvent-proof type (see PRECAUTIONS AND GUIDELINES)
- RoHS Compliant



◆ SPECIFICATIONS

Items	Characteristics										
Category Temperature Range	-55 to +105°C										
Rated Voltage Range	6.3 to 100V <sub>dc</sub>										
Capacitance Tolerance	±20% (M) (at 20°C, 120Hz)										
Leakage Current	I=0.01CV or 3μA, whichever is greater. Where, I : Max. leakage current (μA), C : Nominal capacitance (μF), V : Rated voltage (V) (at 20°C after 2 minutes)										
Dissipation Factor (tanδ)	Rated voltage (V <sub>dc</sub> )	6.3V	10V	16V	25V	35V	50V	63V	80V	100V	
	tanδ (Max.)	0.22	0.19	0.16	0.14	0.12	0.10	0.10	0.09	0.08	
	When nominal capacitance exceeds 1,000μF, add 0.02 to the value above for each 1,000μF increase. (at 20°C, 120Hz)										
Low Temperature Characteristics	Capacitance change ΔC (-55°C /+20°C)	0.7min.									
	Max. impedance ratio (-55°C /+20°C)	3max.(6.3V <sub>dc</sub> : 4max.) (at 120Hz)									
Endurance	The following specifications shall be satisfied when the capacitors are restored to 20°C after subjected to DC voltage with the rated ripple current is applied for the specified period of time at 105°C.										
	Time	φ5 to 6.3 : 2,000hours			φ8 & 10 : 3,000hours			φ12.5 to φ18 : 5,000hours			
	Capacitance change	≤±20% of the initial value									
	D.F. (tanδ)	≤200% of the initial specified value									
	Leakage current	≤The initial specified value									
Shelf Life	The following specifications shall be satisfied when the capacitors are restored to 20°C after exposing them for 1,000 hours at 105°C without voltage applied.										
	Capacitance change	≤±20% of the initial value									
	D.F. (tanδ)	≤200% of the initial specified value									
	Leakage current	≤The initial specified value									

◆ DIMENSIONS [mm]

- Terminal Code : E

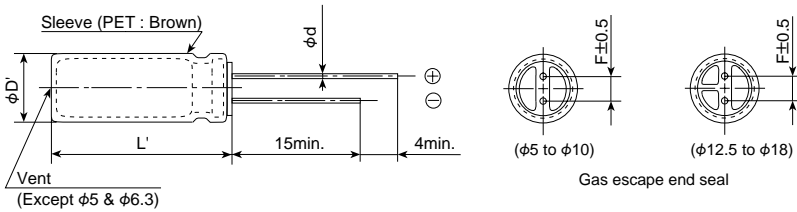

φD	5	6.3	8	10	12.5	16	18
φd	0.5	0.5	0.6	0.6	0.6	0.8	0.8
F	2.0	2.5	3.5	5.0	5.0	7.5	7.5
φD'	φD+0.5max.						
L'	L+1.5max.						

◆ PART NUMBERING SYSTEM

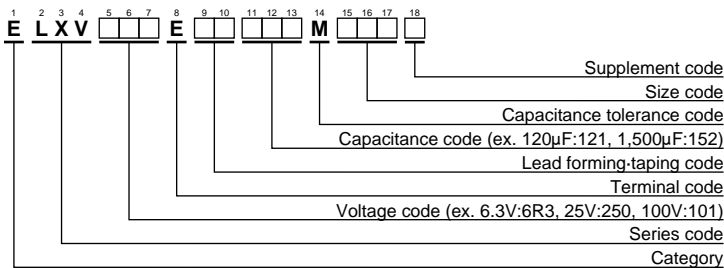

Please refer to "A guide to global code (radial lead type)"

◆STANDARD RATINGS

WV (Vdc)	Cap (μF)	Case size φD×L(mm)	Impedance (Ωmax/100kHz)		Rated ripple current (mArms/ 105°C, 100kHz)	Part No.	WV (Vdc)	Cap (μF)	Case size φD×L(mm)	Impedance (Ωmax/100kHz)		Rated ripple current (mArms/ 105°C, 100kHz)	Part No.	
			20°C	-10°C						20°C	-10°C			
6.3	120	5 × 11.5	0.72	1.8	165	ELXV6R3E□□121MEB5D	16	2,700	12.5 × 35	0.027	0.068	2,230	ELXV160E□□272MK35S	
	220	6.3 × 11.5	0.38	0.95	255	ELXV6R3E□□221MFB5D		2,700	16 × 25	0.028	0.070	2,190	ELXV160E□□272ML25S	
	330	6.3 × 15	0.27	0.68	330	ELXV6R3E□□331MF15D		3,300	12.5 × 40	0.024	0.060	2,460	ELXV160E□□332MK40S	
	390	8 × 12	0.20	0.50	415	ELXV6R3E□□391MH12D		3,300	18 × 20	0.036	0.090	1,940	ELXV160E□□332MM20S	
	470	10 × 12.5	0.12	0.30	635	ELXV6R3E□□471MJC5S		3,900	16 × 30	0.025	0.063	2,510	ELXV160E□□392ML30S	
	560	8 × 15	0.16	0.40	495	ELXV6R3E□□561MH15D		3,900	18 × 25	0.027	0.068	2,350	ELXV160E□□392MM25S	
	680	10 × 16	0.084	0.21	825	ELXV6R3E□□681MJ16S		4,700	16 × 35	0.022	0.055	2,770	ELXV160E□□472ML35S	
	820	8 × 20	0.11	0.28	640	ELXV6R3E□□821MH20D		4,700	18 × 30	0.024	0.060	2,720	ELXV160E□□472MM30S	
	1,200	10 × 20	0.062	0.16	1,060	ELXV6R3E□□122MJ20S		5,600	16 × 40	0.018	0.045	3,110	ELXV160E□□562ML40S	
	1,500	10 × 25	0.052	0.13	1,260	ELXV6R3E□□152MJ25S		6,800	18 × 35	0.021	0.053	3,050	ELXV160E□□682MM35S	
	2,200	10 × 30	0.044	0.11	1,450	ELXV6R3E□□222MJ30S		8,200	18 × 40	0.017	0.043	3,300	ELXV160E□□822MM40S	
	2,200	12.5 × 20	0.046	0.12	1,360	ELXV6R3E□□222MK20S		25	39	5 × 11.5	0.72	1.8	165	ELXV250E□□390MEB5D
	2,700	12.5 × 25	0.034	0.085	1,700	ELXV6R3E□□272MK25S			82	6.3 × 11.5	0.38	0.95	255	ELXV250E□□820MFB5D
	3,900	12.5 × 30	0.030	0.075	1,980	ELXV6R3E□□392MK30S			120	6.3 × 15	0.27	0.68	330	ELXV250E□□121MF15D
	3,900	16 × 20	0.038	0.095	1,770	ELXV6R3E□□392ML20S			150	8 × 12	0.20	0.50	415	ELXV250E□□151MH12D
	4,700	12.5 × 35	0.027	0.068	2,230	ELXV6R3E□□472MK35S			180	10 × 12.5	0.12	0.30	635	ELXV250E□□181MJC5S
	5,600	12.5 × 40	0.024	0.060	2,460	ELXV6R3E□□562MK40S			220	8 × 15	0.16	0.40	495	ELXV250E□□221MH15D
	5,600	16 × 25	0.028	0.070	2,190	ELXV6R3E□□562ML25S			330	8 × 20	0.11	0.28	640	ELXV250E□□331MH20D
5,600	18 × 20	0.036	0.090	1,940	ELXV6R3E□□562MM20S	330	10 × 16		0.084	0.21	825	ELXV250E□□331MJ16S		
6,800	16 × 30	0.025	0.063	2,510	ELXV6R3E□□682ML30S	470	10 × 20		0.062	0.16	1,060	ELXV250E□□471MJ20S		
6,800	18 × 25	0.027	0.068	2,350	ELXV6R3E□□682MM25S	560	10 × 25		0.052	0.13	1,260	ELXV250E□□561MJ25S		
8,200	16 × 35	0.022	0.055	2,770	ELXV6R3E□□822ML35S	820	10 × 30		0.044	0.11	1,450	ELXV250E□□821MJ30S		
10,000	16 × 40	0.018	0.045	3,110	ELXV6R3E□□103ML40S	820	12.5 × 20		0.046	0.12	1,360	ELXV250E□□821MK20S		
10,000	18 × 30	0.024	0.060	2,720	ELXV6R3E□□103MM30S	1,000	12.5 × 25		0.034	0.085	1,700	ELXV250E□□102MK25S		
12,000	18 × 35	0.021	0.053	3,050	ELXV6R3E□□123MM35S	1,500	12.5 × 30		0.030	0.075	1,980	ELXV250E□□152MK30S		
15,000	18 × 40	0.017	0.043	3,300	ELXV6R3E□□153MM40S	1,500	16 × 20		0.038	0.095	1,770	ELXV250E□□152ML20S		
10	82	5 × 11.5	0.72	1.8	165	ELXV100E□□820MEB5D	1,800		12.5 × 35	0.027	0.068	2,230	ELXV250E□□182MK35S	
	180	6.3 × 11.5	0.38	0.95	255	ELXV100E□□181MFB5D	1,800		16 × 25	0.028	0.070	2,190	ELXV250E□□182ML25S	
	270	6.3 × 15	0.27	0.68	330	ELXV100E□□271MF15D	2,200		12.5 × 40	0.024	0.060	2,460	ELXV250E□□222MK40S	
	330	8 × 12	0.20	0.50	415	ELXV100E□□331MH12D	2,200	18 × 20	0.036	0.090	1,940	ELXV250E□□222MM20S		
	390	10 × 12.5	0.12	0.30	635	ELXV100E□□391MJC5S	2,700	16 × 30	0.025	0.063	2,510	ELXV250E□□272ML30S		
	470	8 × 15	0.16	0.40	495	ELXV100E□□471MH15D	2,700	18 × 25	0.027	0.068	2,350	ELXV250E□□272MM25S		
	680	8 × 20	0.11	0.28	640	ELXV100E□□681MH20D	3,300	16 × 35	0.022	0.055	2,770	ELXV250E□□332ML35S		
	680	10 × 16	0.084	0.21	825	ELXV100E□□681MJ16S	3,300	18 × 30	0.024	0.060	2,720	ELXV250E□□332MM30S		
	1,000	10 × 20	0.062	0.16	1,060	ELXV100E□□102MJ20S	3,900	16 × 40	0.018	0.045	3,110	ELXV250E□□392ML40S		
	1,200	10 × 25	0.052	0.13	1,260	ELXV100E□□122MJ25S	3,900	18 × 35	0.021	0.053	3,050	ELXV250E□□392MM35S		
	1,500	10 × 30	0.044	0.11	1,450	ELXV100E□□152MJ30S	4,700	18 × 40	0.017	0.043	3,300	ELXV250E□□472MM40S		
	1,800	12.5 × 20	0.046	0.12	1,360	ELXV100E□□182MK20S	35	27	5 × 11.5	0.72	1.8	165	ELXV350E□□270MEB5D	
	2,200	12.5 × 25	0.034	0.085	1,700	ELXV100E□□222MK25S		56	6.3 × 11.5	0.38	0.95	255	ELXV350E□□560MFB5D	
	2,700	12.5 × 30	0.030	0.075	1,980	ELXV100E□□272MK30S		82	6.3 × 15	0.27	0.68	330	ELXV350E□□820MF15D	
	3,300	12.5 × 35	0.027	0.068	2,230	ELXV100E□□332MK35S		120	8 × 12	0.20	0.50	415	ELXV350E□□121MH12D	
	3,300	16 × 20	0.038	0.095	1,770	ELXV100E□□332ML20S		120	10 × 12.5	0.12	0.30	635	ELXV350E□□121MJC5S	
	3,900	12.5 × 40	0.024	0.060	2,460	ELXV100E□□392MK40S		180	8 × 15	0.16	0.40	495	ELXV350E□□181MH15D	
	3,900	16 × 25	0.028	0.070	2,190	ELXV100E□□392ML25S		220	8 × 20	0.11	0.28	640	ELXV350E□□221MH20D	
3,900	18 × 20	0.036	0.090	1,940	ELXV100E□□392MM20S	220		10 × 16	0.084	0.21	825	ELXV350E□□221MJ16S		
4,700	18 × 25	0.027	0.068	2,350	ELXV100E□□472MM25S	330		10 × 20	0.062	0.16	1,060	ELXV350E□□331MJ20S		
5,600	16 × 30	0.025	0.063	2,510	ELXV100E□□562ML30S	390		10 × 25	0.052	0.13	1,260	ELXV350E□□391MJ25S		
6,800	16 × 35	0.022	0.055	2,770	ELXV100E□□682ML35S	560		10 × 30	0.044	0.11	1,450	ELXV350E□□561MJ30S		
6,800	18 × 30	0.024	0.060	2,720	ELXV100E□□682MM30S	560		12.5 × 20	0.046	0.12	1,360	ELXV350E□□561MK20S		
8,200	16 × 40	0.018	0.045	3,110	ELXV100E□□822ML40S	680		12.5 × 25	0.034	0.085	1,700	ELXV350E□□681MK25S		
8,200	18 × 35	0.021	0.053	3,050	ELXV100E□□822MM35S	1,000		12.5 × 30	0.030	0.075	1,980	ELXV350E□□102MK30S		
10,000	18 × 40	0.017	0.043	3,300	ELXV100E□□103MM40S	1,000		16 × 20	0.038	0.095	1,770	ELXV350E□□102ML20S		
16	56	5 × 11.5	0.72	1.8	165	ELXV160E□□560MEB5D		1,200	12.5 × 35	0.027	0.068	2,230	ELXV350E□□122MK35S	
	120	6.3 × 11.5	0.38	0.95	255	ELXV160E□□121MFB5D		1,200	16 × 25	0.028	0.070	2,190	ELXV350E□□122ML25S	
	180	6.3 × 15	0.27	0.68	330	ELXV160E□□181MF15D		1,500	12.5 × 40	0.024	0.060	2,460	ELXV350E□□152MK40S	
	270	8 × 12	0.20	0.50	415	ELXV160E□□271MH12D	1,500	18 × 20	0.036	0.090	1,940	ELXV350E□□820MM20S		
	270	10 × 12.5	0.12	0.30	635	ELXV160E□□271MJC5S	1,800	16 × 30	0.025	0.063	2,510	ELXV350E□□182ML30S		
	330	8 × 15	0.16	0.40	495	ELXV160E□□331MH15D	1,800	18 × 25	0.027	0.068	2,350	ELXV350E□□182MM25S		
	470	8 × 20	0.11	0.28	640	ELXV160E□□471MH20D	2,200	16 × 35	0.022	0.055	2,770	ELXV350E□□222ML35S		
	470	10 × 16	0.084	0.21	825	ELXV160E□□471MJ16S	2,200	18 × 30	0.024	0.060	2,720	ELXV350E□□222MM30S		
	680	10 × 20	0.062	0.16	1,060	ELXV160E□□681MJ20S	2,700	16 × 40	0.018	0.045	3,110	ELXV350E□□272ML40S		
	820	10 × 25	0.052	0.13	1,260	ELXV160E□□821MJ25S	2,700	18 × 35	0.021	0.053	3,050	ELXV350E□□272MM35S		
	1,200	10 × 30	0.044	0.11	1,450	ELXV160E□□122MJ30S	3,300	18 × 40	0.017	0.043	3,300	ELXV350E□□332MM40S		
	1,200	12.5 × 20	0.046	0.12	1,360	ELXV160E□□122MK20S	50	18	5 × 11.5	1.1	3.3	165	ELXV500E□□180MEB5D	
	1,500	12.5 × 25	0.034	0.085	1,700	ELXV160E□□152MK25S		39	6.3 × 11.5	0.56	1.6	255	ELXV500E□□390MFB5D	
	2,200	12.5 × 30	0.030	0.075	1,980	ELXV160E□□222MK30S		56	6.3 × 15	0.41	1.2	310	ELXV500E□□560MF15D	
	2,200	16 × 20	0.038	0.095	1,770	ELXV160E□□222ML20S		68	8 × 12	0.29	0.84	415	ELXV500E□□680MH12D	

□ : Lead forming / Taping code



◆STANDARD RATINGS

WV (Vdc)	Cap (μF)	Case size φD×L(mm)	Impedance (Ωmax/100kHz)		Rated ripple current (mA <sub>rms</sub> /105°C, 100kHz)	Part No.	WV (Vdc)	Cap (μF)	Case size φD×L(mm)	Impedance (Ωmax/100kHz)		Rated ripple current (mA <sub>rms</sub> /105°C, 100kHz)	Part No.
			20°C	-10°C						20°C	-10°C		
50	82	8 × 15	0.24	0.72	505	ELXV500E□□820MH15D	80	27	6.3 × 15	0.62	1.7	220	ELXV800E□□270MF15D
	82	10 × 12.5	0.16	0.40	530	ELXV500E□□820MJC5S		33	8 × 12	0.53	1.5	275	ELXV800E□□330MH12D
	120	8 × 20	0.18	0.52	610	ELXV500E□□121MH20D		39	10 × 12.5	0.47	1.3	380	ELXV800E□□390MJC5S
	120	10 × 16	0.12	0.30	755	ELXV500E□□121MJ16S		47	8 × 15	0.35	0.97	360	ELXV800E□□470MH15D
	180	10 × 20	0.088	0.22	945	ELXV500E□□181MJ20S		56	8 × 20	0.27	0.74	490	ELXV800E□□560MH20D
	220	10 × 25	0.068	0.17	1,150	ELXV500E□□221MJ25S		56	10 × 16	0.33	0.90	500	ELXV800E□□560MJ16S
	330	10 × 30	0.059	0.15	1,260	ELXV500E□□331MJ30S		82	10 × 20	0.26	0.70	620	ELXV800E□□820MJ20S
	330	12.5 × 20	0.059	0.15	1,190	ELXV500E□□331MK20S		100	10 × 25	0.19	0.52	795	ELXV800E□□101MJ25S
	470	12.5 × 25	0.045	0.11	1,500	ELXV500E□□471MK25S		150	10 × 30	0.15	0.41	955	ELXV800E□□151MJ30S
	560	12.5 × 30	0.039	0.098	1,720	ELXV500E□□561MK30S		150	12.5 × 20	0.15	0.41	890	ELXV800E□□151MK20S
	680	12.5 × 35	0.033	0.083	1,900	ELXV500E□□681MK35S		180	12.5 × 25	0.11	0.30	1,040	ELXV800E□□181MK25S
	680	16 × 20	0.043	0.11	1,500	ELXV500E□□681ML20S		270	12.5 × 30	0.094	0.26	1,270	ELXV800E□□271MK30S
	820	12.5 × 40	0.029	0.073	2,120	ELXV500E□□821MK40S		270	16 × 20	0.11	0.30	1,240	ELXV800E□□271ML20S
	820	16 × 25	0.033	0.083	1,880	ELXV500E□□821ML25S		330	12.5 × 35	0.087	0.24	1,450	ELXV800E□□331MK35S
	820	18 × 20	0.039	0.098	1,660	ELXV500E□□821MM20S		330	16 × 25	0.081	0.22	1,440	ELXV800E□□331ML25S
	1,000	16 × 30	0.029	0.073	2,150	ELXV500E□□102ML30S		390	12.5 × 40	0.060	0.17	1,610	ELXV800E□□391MK40S
	1,000	18 × 25	0.030	0.075	2,020	ELXV500E□□102MM25S		390	18 × 20	0.085	0.23	1,450	ELXV800E□□391MM20S
	1,200	16 × 35	0.025	0.063	2,320	ELXV500E□□122ML35S		470	16 × 30	0.058	0.16	1,790	ELXV800E□□471ML30S
	1,500	16 × 40	0.021	0.053	2,650	ELXV500E□□152ML40S		470	18 × 25	0.070	0.19	1,650	ELXV800E□□471MM25S
	1,500	18 × 30	0.026	0.065	2,340	ELXV500E□□152MM30S		560	16 × 35	0.052	0.14	2,000	ELXV800E□□561ML35S
1,800	18 × 35	0.023	0.058	2,620	ELXV500E□□182MM35S	680	16 × 40	0.041	0.11	2,200	ELXV800E□□681ML40S		
2,200	18 × 40	0.020	0.050	2,790	ELXV500E□□222MM40S	680	18 × 30	0.058	0.16	1,850	ELXV800E□□681MM30S		
63	12	5 × 11.5	1.9	4.8	100	ELXV630E□□120MEB5D	1,000	18 × 35	0.052	0.14	1,990	ELXV800E□□821MM35S	
	27	6.3 × 11.5	1.1	2.8	160	ELXV630E□□270MFB5D	1,000	18 × 40	0.041	0.11	2,370	ELXV800E□□102MM40S	
	39	6.3 × 15	0.62	1.6	230	ELXV630E□□390MF15D	100	5.6	5 × 11.5	1.9	5.1	100	ELXV101E□□5R6MEB5D
	47	8 × 12	0.49	1.3	275	ELXV630E□□470MH12D		12	6.3 × 11.5	1.1	3.0	150	ELXV101E□□120MFB5D
	56	10 × 12.5	0.27	0.68	420	ELXV630E□□560MJC5S		18	6.3 × 15	0.62	1.7	220	ELXV101E□□180MF15D
	68	8 × 15	0.34	0.85	360	ELXV630E□□680MH15D		22	8 × 12	0.53	1.5	275	ELXV101E□□220MH12D
	68	10 × 16	0.21	0.53	523	ELXV630E□□680MJ16S		27	10 × 12.5	0.47	1.3	380	ELXV101E□□270MJC5S
	82	8 × 20	0.21	0.53	500	ELXV630E□□820MH20D		33	8 × 15	0.35	0.97	360	ELXV101E□□330MH15D
	120	10 × 20	0.16	0.40	650	ELXV630E□□121MJ20S		33	10 × 16	0.33	0.90	500	ELXV101E□□330MJ16S
	150	10 × 25	0.13	0.33	780	ELXV630E□□151MJ25S		39	8 × 20	0.27	0.74	490	ELXV101E□□390MH20D
	180	10 × 30	0.10	0.25	960	ELXV630E□□181MJ30S		56	10 × 20	0.26	0.70	620	ELXV101E□□560MJ20S
	220	12.5 × 20	0.11	0.28	870	ELXV630E□□221MK20S		68	10 × 25	0.19	0.52	795	ELXV101E□□680MJ25S
	270	12.5 × 25	0.074	0.19	1,150	ELXV630E□□271MK25S		100	10 × 30	0.15	0.41	955	ELXV101E□□101MJ30S
	390	12.5 × 30	0.068	0.17	1,280	ELXV630E□□391MK30S		100	12.5 × 20	0.15	0.41	890	ELXV101E□□101MK20S
	390	16 × 20	0.085	0.22	1,100	ELXV630E□□391ML20S		120	12.5 × 25	0.11	0.30	1,040	ELXV101E□□121MK25S
	470	12.5 × 35	0.063	0.16	1,390	ELXV630E□□471MK35S		180	12.5 × 30	0.094	0.26	1,270	ELXV101E□□181MK30S
	470	16 × 25	0.055	0.14	1,480	ELXV630E□□471ML25S		180	16 × 20	0.11	0.30	1,240	ELXV101E□□181ML20S
	560	12.5 × 40	0.051	0.13	1,530	ELXV630E□□561MK40S		220	12.5 × 35	0.087	0.24	1,450	ELXV101E□□221MK35S
	560	18 × 20	0.085	0.22	1,170	ELXV630E□□561MM20S		220	16 × 25	0.081	0.22	1,440	ELXV101E□□221ML25S
	680	16 × 30	0.046	0.12	1,720	ELXV630E□□681ML30S		270	12.5 × 40	0.060	0.17	1,610	ELXV101E□□271MK40S
680	18 × 25	0.055	0.14	1,520	ELXV630E□□681MM25S	270		18 × 20	0.085	0.23	1,450	ELXV101E□□271MM20S	
820	16 × 35	0.040	0.10	1,910	ELXV630E□□821ML35S	330		16 × 30	0.058	0.16	1,790	ELXV101E□□331ML30S	
820	18 × 30	0.046	0.12	1,770	ELXV630E□□821MM30S	330	18 × 25	0.070	0.19	1,650	ELXV101E□□331MM25S		
1,000	16 × 40	0.036	0.09	2,070	ELXV630E□□102ML40S	390	16 × 35	0.052	0.14	2,000	ELXV101E□□391ML35S		
1,000	18 × 35	0.040	0.10	1,970	ELXV630E□□102MM35S	390	18 × 30	0.058	0.16	1,850	ELXV101E□□391MM30S		
1,200	18 × 40	0.036	0.09	2,130	ELXV630E□□122MM40S	470	16 × 40	0.041	0.11	2,200	ELXV101E□□471ML40S		
80	8.2	5 × 11.5	1.9	5.1	100	ELXV800E□□8R2MEB5D	560	18 × 35	0.052	0.14	1,990	ELXV101E□□561MM35S	
	18	6.3 × 11.5	1.1	3.0	150	ELXV800E□□180MFB5D	680	18 × 40	0.041	0.11	2,370	ELXV101E□□681MM40S	

□ □ : Lead forming / Taping code

◆RATED RIPPLE CURRENT MULTIPLIERS

●Frequency Multipliers

Rated voltage (V <sub>dc</sub> )	Case size φD (mm)	Frequency (Hz)				Rated voltage (V <sub>dc</sub> )	Case size φD (mm)	Frequency (Hz)			
		120	1k	10k	100k			120	1k	10k	100k
6.3 & 10	5 to 8	0.65	0.83	0.95	1.00	35 & 50	5 to 8	0.40	0.66	0.85	1.00
	10 & 12.5	0.70	0.85	0.96	1.00		10 & 12.5	0.50	0.73	0.89	1.00
	16 & 18	0.85	0.92	0.97	1.00		16 & 18	0.60	0.81	0.94	1.00
16 & 25	5 to 8	0.55	0.76	0.91	1.00	63 to 100	5 to 8	0.20	0.55	0.80	1.00
	10 & 12.5	0.65	0.83	0.93	1.00		10 & 12.5	0.35	0.65	0.85	1.00
	16 & 18	0.70	0.87	0.96	1.00		16 & 18	0.50	0.75	0.90	1.00

The endurance of capacitors is shorted with internal heating produced by ripple current at the rate of halving the lifetime with every 5°C rise.

When long life performance is required in actual use, the rms ripple current has to be reduced.

New!

**KXJ Series**

- Downsized and Longer life from current KXG series
- Endurance with ripple current : 10,000 to 12,000 hours at 105°C
- Rated voltage range : 160 to 400V<sub>dc</sub>, Capacitance range : 10 to 680μF
- For electronic ballast circuits and other long life required applications
- Non solvent-proof type
- RoHS Compliant

**KXJ**

↓  
Downsized  
↑  
KXG



◆ SPECIFICATIONS

Items	Characteristics		
Category	—40 to +105°C (160 to 400V <sub>dc</sub> )		
Temperature Range	—40 to +105°C (160 to 400V <sub>dc</sub> )		
Rated Voltage Range	160 to 400V <sub>dc</sub>		
Capacitance Tolerance	±20% (M) (at 20°C, 120Hz)		
Leakage Current		After 1 minute	After 5 minutes
	CV ≤ 1000	I = 0.1CV + 40	I = 0.03CV + 15
	CV > 1000	I = 0.04CV + 100	I = 0.02CV + 25
	Where, I : Max. leakage current (μA), C : Nominal capacitance (μF), V : Rated voltage (V) (at 20°C)		
Dissipation Factor (tanδ)	Rated voltage (V <sub>dc</sub> )	160 to 250V	350 & 400V
	tanδ (Max.)	0.20	0.24
	(at 20°C, 120Hz)		
Low Temperature Characteristics (Max. Impedance Ratio)	Rated voltage (V <sub>dc</sub> )	160 to 250V	350 & 400V
	Z(-25°C)/Z(+20°C)	3	5
	Z(-40°C)/Z(+20°C)	6	6
	(at 120Hz)		
Endurance	The following specifications shall be satisfied when the capacitors are restored to 20°C after subjected to DC voltage with the rated ripple current is applied for 12,000 hours (10,000 hours for 20L max.) at 105°C.		
	Capacitance change	≤ ±20% of the initial value	
	D.F. (tanδ)	≤ 200% of the initial specified value	
	Leakage current	≤ The initial specified value	
Shelf Life	The following specifications shall be satisfied when the capacitors are restored to 20°C after exposing them for 1000 hours at 105°C without voltage applied.		
	Capacitance change	≤ ±20% of the initial value	
	D.F. (tanδ)	≤ 200% of the initial specified value	
	Leakage current	≤ 500% of the initial specified value	

◆ DIMENSIONS [mm]

- Terminal Code : E

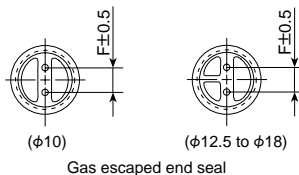
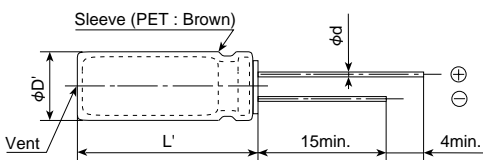

	10	12.5	14.5	16	18
φD	10	12.5	14.5	16	18
φd	0.6	0.6	0.8	0.8	0.8
F	5.0	5.0	7.5	7.5	7.5
φD'	φD + 0.5max.				
L'	L + 1.5max.				

◆ PART NUMBERING SYSTEM

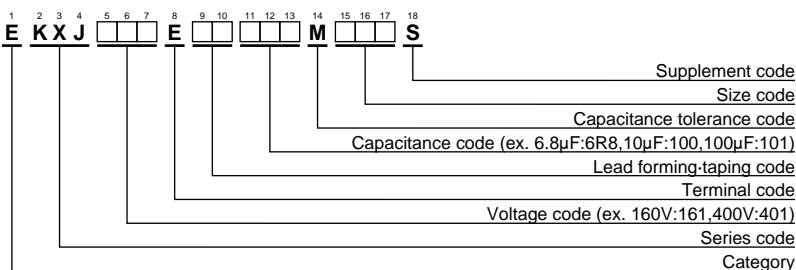

Please refer to "A guide to global code (radial lead type)"





# MINIATURE ALUMINUM ELECTROLYTIC CAPACITORS

160 to 400Vdc long life, 105°C

**New!**  
**KXJ Series**

## ◆STANDARD RATINGS

WV (Vdc)	Cap (μF)	Case size φDXL(mm)	tanδ	Rated ripple current (Arms/105°C,120Hz)	Part No.	WV (Vdc)	Cap (μF)	Case size φDXL(mm)	tanδ	Rated ripple current (Arms/105°C,120Hz)	Part No.
160	39	10×16	0.20	245	EKXJ161E□□390MJ16S	200	560	18×50	0.20	1,945	EKXJ201E□□561MM50S
	56	10×20	0.20	315	EKXJ161E□□560MJ20S		27	10×16	0.20	200	EKXJ221E□□270MJ16S
	68	10×25	0.20	380	EKXJ161E□□680MJ25S		39	10×20	0.20	265	EKXJ221E□□390MJ20S
	82	10×30	0.20	445	EKXJ161E□□820MJ30S		47	10×25	0.20	315	EKXJ221E□□470MJ25S
	100	12.5×20	0.20	575	EKXJ161E□□101MK20S		56	10×30	0.20	370	EKXJ221E□□560MJ30S
	120	10×35	0.20	570	EKXJ161E□□121MJ35S		68	12.5×20	0.20	475	EKXJ221E□□680MK20S
	120	12.5×25	0.20	680	EKXJ161E□□121MK25S		82	10×35	0.20	470	EKXJ221E□□820MJ35S
	120	14.5×20	0.20	675	EKXJ161E□□121MU20S		82	12.5×25	0.20	565	EKXJ221E□□820MK25S
	150	10×45	0.20	695	EKXJ161E□□151MJ45S		82	14.5×20	0.20	555	EKXJ221E□□820MU20S
	150	12.5×30	0.20	810	EKXJ161E□□151MK30S		100	10×45	0.20	565	EKXJ221E□□101MJ45S
	150	16×20	0.20	780	EKXJ161E□□151ML20S		100	12.5×30	0.20	660	EKXJ221E□□101MK30S
	180	10×50	0.20	785	EKXJ161E□□181MJ50S		100	16×20	0.20	635	EKXJ221E□□101ML20S
	180	12.5×35	0.20	940	EKXJ161E□□181MK35S		120	10×50	0.20	645	EKXJ221E□□121MJ50S
	180	14.5×25	0.20	890	EKXJ161E□□181MU25S		120	12.5×35	0.20	770	EKXJ221E□□121MK35S
	220	12.5×40	0.20	1,075	EKXJ161E□□221MK40S		120	14.5×25	0.20	725	EKXJ221E□□121MU25S
	220	16×25	0.20	1,020	EKXJ161E□□221ML25S		150	12.5×40	0.20	890	EKXJ221E□□151MK40S
	220	18×20	0.20	990	EKXJ161E□□221MM20S		150	16×25	0.20	845	EKXJ221E□□151ML25S
	270	12.5×45	0.20	1,230	EKXJ161E□□271MK45S		150	18×20	0.20	815	EKXJ221E□□151MM20S
	270	14.5×31.5	0.20	1,170	EKXJ161E□□271MUN3S		180	12.5×45	0.20	1,005	EKXJ221E□□181MK45S
	330	12.5×50	0.20	1,400	EKXJ161E□□331MK50S		180	14.5×31.5	0.20	955	EKXJ221E□□181MUN3S
	330	14.5×40	0.20	1,385	EKXJ161E□□331MU40S		180	18×25	0.20	950	EKXJ221E□□181MM25S
	330	16×31.5	0.20	1,350	EKXJ161E□□331MLN3S		220	12.5×50	0.20	1,145	EKXJ221E□□221MK50S
	330	18×25	0.20	1,290	EKXJ161E□□331MM25S		220	14.5×35.5	0.20	1,095	EKXJ221E□□221MUP1S
	390	14.5×45	0.20	1,545	EKXJ161E□□391MU45S		270	14.5×45	0.20	1,285	EKXJ221E□□271MU45S
	390	16×40	0.20	1,545	EKXJ161E□□391ML40S		270	16×40	0.20	1,285	EKXJ221E□□271ML40S
	390	18×31.5	0.20	1,515	EKXJ161E□□391MMN3S		270	18×31.5	0.20	1,260	EKXJ221E□□271MMN3S
	470	14.5×50	0.20	1,735	EKXJ161E□□471MU50S		330	16×50	0.20	1,480	EKXJ221E□□331ML50S
470	16×45	0.20	1,730	EKXJ161E□□471ML45S	330	18×35.5	0.20	1,440	EKXJ221E□□331MMP1S		
470	18×35.5	0.20	1,715	EKXJ161E□□471MMP1S	390	18×45	0.20	1,620	EKXJ221E□□391MM45S		
560	16×50	0.20	1,920	EKXJ161E□□561ML50S	470	18×50	0.20	1,785	EKXJ221E□□471MM50S		
560	18×40	0.20	1,905	EKXJ161E□□561MM40S	22	10×16	0.20	185	EKXJ251E□□220MJ16S		
680	18×50	0.20	2,145	EKXJ161E□□681MM50S	33	10×20	0.20	240	EKXJ251E□□330MJ20S		
200	27	10×16	0.20	200	EKXJ201E□□270MJ16S	39	10×25	0.20	285	EKXJ251E□□390MJ25S	
	47	10×20	0.20	290	EKXJ201E□□470MJ20S	47	10×30	0.20	340	EKXJ251E□□470MJ30S	
	56	10×25	0.20	345	EKXJ201E□□560MJ25S	56	12.5×20	0.20	430	EKXJ251E□□560MK20S	
	68	10×30	0.20	405	EKXJ201E□□680MJ30S	68	10×35	0.20	430	EKXJ251E□□680MJ35S	
	68	12.5×20	0.20	475	EKXJ201E□□680MK20S	68	12.5×25	0.20	515	EKXJ251E□□680MK25S	
	82	10×35	0.20	470	EKXJ201E□□820MJ35S	68	14.5×20	0.20	505	EKXJ251E□□680MU20S	
	100	10×40	0.20	545	EKXJ201E□□101MJ40S	82	10×45	0.20	515	EKXJ251E□□820MJ45S	
	100	12.5×25	0.20	625	EKXJ201E□□101MK25S	82	12.5×30	0.20	600	EKXJ251E□□820MK30S	
	100	14.5×20	0.20	615	EKXJ201E□□101MU20S	82	16×20	0.20	575	EKXJ251E□□820ML20S	
	120	10×45	0.20	620	EKXJ201E□□121MJ45S	100	10×50	0.20	585	EKXJ251E□□101MJ50S	
	120	12.5×30	0.20	725	EKXJ201E□□121MK30S	100	12.5×35	0.20	700	EKXJ251E□□101MK35S	
	120	16×20	0.20	695	EKXJ201E□□121ML20S	100	14.5×25	0.20	665	EKXJ251E□□101MU25S	
	150	10×50	0.20	720	EKXJ201E□□151MJ50S	120	12.5×40	0.20	795	EKXJ251E□□121MK40S	
	150	12.5×35	0.20	860	EKXJ201E□□151MK35S	120	16×25	0.20	755	EKXJ251E□□121ML25S	
	150	14.5×25	0.20	810	EKXJ201E□□151MU25S	120	18×20	0.20	730	EKXJ251E□□121MM20S	
	150	18×20	0.20	815	EKXJ201E□□151MM20S	150	12.5×45	0.20	920	EKXJ251E□□151MK45S	
	180	12.5×40	0.20	975	EKXJ201E□□181MK40S	150	14.5×31.5	0.20	870	EKXJ251E□□151MUN3S	
	180	14.5×31.5	0.20	955	EKXJ201E□□181MUN3S	150	18×25	0.20	870	EKXJ251E□□151MM25S	
	180	16×25	0.20	925	EKXJ201E□□181ML25S	180	12.5×50	0.20	1,035	EKXJ251E□□181MK50S	
	220	12.5×45	0.20	1,110	EKXJ201E□□221MK45S	180	14.5×40	0.20	1,020	EKXJ251E□□181MU40S	
	220	14.5×35.5	0.20	1,095	EKXJ201E□□221MUP1S	180	16×31.5	0.20	995	EKXJ251E□□181MLN3S	
	220	16×31.5	0.20	1,100	EKXJ201E□□221MLN3S	220	14.5×45	0.20	1,160	EKXJ251E□□221MU45S	
	220	18×25	0.20	1,050	EKXJ201E□□221MM25S	220	16×40	0.20	1,160	EKXJ251E□□221ML40S	
	270	14.5×40	0.20	1,250	EKXJ201E□□271MU40S	220	18×31.5	0.20	1,135	EKXJ251E□□221MMN3S	
	270	16×35.5	0.20	1,250	EKXJ201E□□271MLP1S	270	16×50	0.20	1,330	EKXJ251E□□271ML50S	
	330	14.5×50	0.20	1,450	EKXJ201E□□331MU50S	270	18×35.5	0.20	1,300	EKXJ251E□□271MMP1S	
	330	16×40	0.20	1,425	EKXJ201E□□331ML40S	330	18×45	0.20	1,485	EKXJ251E□□331MM45S	
330	18×31.5	0.20	1,395	EKXJ201E□□331MMN3S	390	18×50	0.20	1,625	EKXJ251E□□391MM50S		
390	16×50	0.20	1,600	EKXJ201E□□391ML50S	12	10×16	0.24	135	EKXJ351E□□120MJ16S		
390	18×40	0.20	1,590	EKXJ201E□□391MM40S	18	10×20	0.24	180	EKXJ351E□□180MJ20S		
470	18×45	0.20	1,770	EKXJ201E□□471MM45S	22	10×25	0.24	215	EKXJ351E□□220MJ25S		

□□ : Lead forming / Taping code

◆STANDARD RATINGS

WV (Vdc)	Cap (μF)	Case size φD×L(mm)	tanδ	Rated ripple current (Arms/105°C,120Hz)	Part No.	WV (Vdc)	Cap (μF)	Case size φD×L(mm)	tanδ	Rated ripple current (Arms/105°C,120Hz)	Part No.
350	27	10×30	0.24	255	EKXJ351E□□270MJ30S	400	10	10×16	0.24	125	EKXJ401E□□100MJ16S
	33	12.5×20	0.24	330	EKXJ351E□□330MK20S		15	10×20	0.24	165	EKXJ401E□□150MJ20S
	39	10×35	0.24	325	EKXJ351E□□390MJ35S		18	10×25	0.24	195	EKXJ401E□□180MJ25S
	47	10×40	0.24	375	EKXJ351E□□470MJ40S		22	10×30	0.24	230	EKXJ401E□□220MJ30S
	47	12.5×25	0.24	425	EKXJ351E□□470MK25S		27	12.5×20	0.24	300	EKXJ401E□□270MK20S
	47	14.5×20	0.24	420	EKXJ351E□□470MU20S		33	10×35	0.24	300	EKXJ401E□□330MJ35S
	56	12.5×30	0.24	495	EKXJ351E□□560MK30S		39	10×40	0.24	340	EKXJ401E□□390MJ40S
	56	16×20	0.24	475	EKXJ351E□□560ML20S		39	12.5×25	0.24	390	EKXJ401E□□390MK25S
	68	10×50	0.24	485	EKXJ351E□□680MJ50S		39	14.5×20	0.24	385	EKXJ401E□□390MU20S
	68	12.5×35	0.24	580	EKXJ351E□□680MK35S		47	16×20	0.24	435	EKXJ401E□□470ML20S
	68	14.5×25	0.24	545	EKXJ351E□□680MU25S		56	10×50	0.24	440	EKXJ401E□□560MJ50S
	68	18×20	0.24	550	EKXJ351E□□680MM20S		56	12.5×35	0.24	525	EKXJ401E□□560MK35S
	82	12.5×40	0.24	655	EKXJ351E□□820MK40S		56	14.5×25	0.24	495	EKXJ401E□□560MU25S
	82	14.5×31.5	0.24	645	EKXJ351E□□820MUN3S		56	18×20	0.24	500	EKXJ401E□□560MM20S
	100	12.5×50	0.24	770	EKXJ351E□□101MK50S		68	12.5×40	0.24	600	EKXJ401E□□680MK40S
	100	14.5×35.5	0.24	740	EKXJ351E□□101MUP1S		68	14.5×31.5	0.24	585	EKXJ401E□□680MUN3S
	100	16×31.5	0.24	740	EKXJ351E□□101MLN3S		82	12.5×50	0.24	700	EKXJ401E□□820MK50S
	100	18×25	0.24	710	EKXJ351E□□101MM25S		82	14.5×35.5	0.24	670	EKXJ401E□□820MUP1S
	120	14.5×40	0.24	835	EKXJ351E□□121MU40S		82	16×31.5	0.24	670	EKXJ401E□□820MLN3S
	120	16×35.5	0.24	830	EKXJ351E□□121MLP1S		82	18×25	0.24	640	EKXJ401E□□820MM25S
120	18×31.5	0.24	840	EKXJ351E□□121MMN3S	100	14.5×40	0.24	760	EKXJ401E□□101MU40S		
150	14.5×50	0.24	980	EKXJ351E□□151MU50S	100	16×35.5	0.24	760	EKXJ401E□□101MLP1S		
150	16×45	0.24	975	EKXJ351E□□151ML45S	120	14.5×50	0.24	875	EKXJ401E□□121MU50S		
150	18×35.5	0.24	970	EKXJ351E□□151MMP1S	120	16×45	0.24	875	EKXJ401E□□121ML45S		
180	16×50	0.24	1,090	EKXJ351E□□181ML50S	120	18×31.5	0.24	840	EKXJ401E□□121MMN3S		
180	18×40	0.24	1,080	EKXJ351E□□181MM40S	150	16×50	0.24	995	EKXJ401E□□151ML50S		
220	18×50	0.24	1,220	EKXJ351E□□221MM50S	150	18×40	0.24	985	EKXJ401E□□151MM40S		
						180	18×50	0.24	1,105	EKXJ401E□□181MM50S	

□□ : Lead forming / Taping code

◆RATED RIPPLE CURRENT MULTIPLIERS

●Frequency Multipliers

Frequency (Hz)	120	1k	10k	100k
Less than 100μF	1.0	1.75	2.25	2.50
100μF or more	1.0	1.67	1.75	2.25

The ripple current gives aluminum electrolytic capacitors higher internal heat, the increased temperature accelerate the deterioration of the capacitors.

The lifetime is approximately halved with every 5°C rise.

# KXG Series

- Down sized from current KMX series
- For electronic ballast circuits and other long life required applications
- Endurance with ripple current : 8,000 to 10,000hours at 105°C
- Non solvent-proof type
- RoHS Compliant

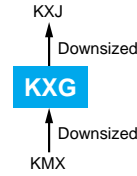

## ◆SPECIFICATIONS

Items	Characteristics			
Category	—40 to +105°C (160 to 400V <sub>dc</sub> ) —25 to +105°C (450V <sub>dc</sub> )			
Temperature Range				
Rated Voltage Range	160 to 450V <sub>dc</sub>			
Capacitance Tolerance	±20% (M) (at 20°C, 120Hz)			
Leakage Current		After 1 minute	After 5 minutes	
	CV ≤ 1,000	I = 0.1CV + 40	I = 0.03CV + 15	
	CV > 1,000	I = 0.04CV + 100	I = 0.02CV + 25	
	Where, I : Max. leakage current (μA), C : Nominal capacitance (μF), V : Rated voltage (V) (at 20°C)			
Dissipation Factor (tanδ)	Rated voltage (V <sub>dc</sub> )	160 to 250V	350 & 400V	450V
	tanδ (Max.)	0.20	0.24	0.24
	(at 20°C, 120Hz)			
Low Temperature Characteristics (Max. Impedance Ratio)	Rated voltage (V <sub>dc</sub> )	160 to 250V	350 & 400V	450V
	Z(-25°C)/Z(+20°C)	3	5	6
	Z(-40°C)/Z(+20°C)	6	6	—
	(at 120Hz)			
Endurance	The following specifications shall be satisfied when the capacitors are restored to 20°C after subjected to DC voltage with the rated ripple current is applied for 10,000 hours (8,000 hours for φ10) at 105°C.			
	Capacitance change	≤ ±20% of the initial value		
	D.F. (tanδ)	≤ 200% of the initial specified value		
	Leakage current	≤ The initial specified value		
Shelf Life	The following specifications shall be satisfied when the capacitors are restored to 20°C after exposing them for 1,000 hours at 105°C without voltage applied.			
	Capacitance change	≤ ±20% of the initial value		
	D.F. (tanδ)	≤ 200% of the initial specified value		
	Leakage current	≤ 500% of the initial specified value		

## ◆DIMENSIONS [mm]

- Terminal Code : E

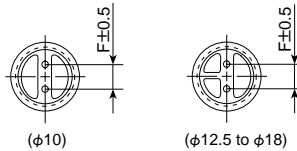
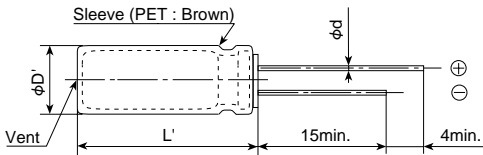

φD	10	12.5	16	18
φd	0.6	0.6	0.8	0.8
F	5.0	5.0	7.5	7.5
φD'	φD+0.5max.			
L'	L+1.5max.			

## ◆PART NUMBERING SYSTEM

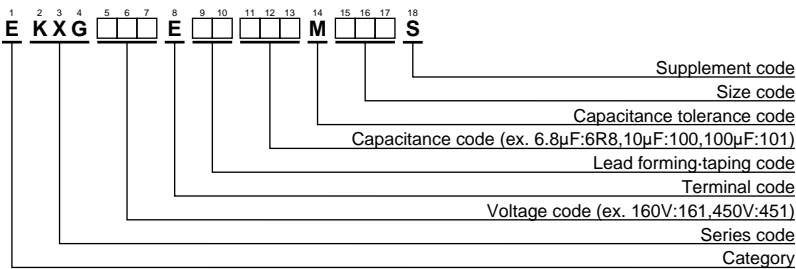

Please refer to "A guide to global code (radial lead type)"

## ◆RATED RIPPLE CURRENT MULTIPLIERS

- Frequency Multipliers

Capacitance (μF)	Frequency (Hz)			
	120	1k	10k	100k
6.8 to 82	1.0	1.75	2.25	2.50
100 to 330	1.0	1.67	1.75	2.25

The endurance of capacitors is shorted with internal heating produced by ripple current at the rate of halving the lifetime with every 5°C rise. When long life performance is required in actual use, the rms ripple current has to be reduced.

**◆STANDARD RATINGS**

WV (V <sub>dc</sub> )	Cap (μF)	Case size φD×L(mm)	tanδ	Rated ripple current(mArms/105°C)		Part No.
				120Hz	100kHz	
160	10	10 × 16	0.20	125	315	EKXG161E□□100MJ16S
	22	10 × 20	0.20	200	500	EKXG161E□□220MJ20S
	33	10 × 20	0.20	250	625	EKXG161E□□330MJ20S
	47	10 × 20	0.20	300	750	EKXG161E□□470MJ20S
	68	12.5 × 20	0.20	470	1,175	EKXG161E□□680MK20S
	82	12.5 × 20	0.20	510	1,275	EKXG161E□□820MK20S
	100	12.5 × 25	0.20	620	1,395	EKXG161E□□101MK25S
	100	16 × 20	0.20	630	1,420	EKXG161E□□101ML20S
	150	16 × 20	0.20	770	1,735	EKXG161E□□151ML20S
	220	16 × 25	0.20	1,020	2,295	EKXG161E□□221ML25S
330	18 × 31.5	0.20	1,390	3,130	EKXG161E□□331MMN3S	
200	10	10 × 16	0.20	125	315	EKXG201E□□100MJ16S
	22	10 × 20	0.20	200	500	EKXG201E□□220MJ20S
	33	10 × 20	0.20	260	650	EKXG201E□□330MJ20S
	47	12.5 × 20	0.20	390	975	EKXG201E□□470MK20S
	68	12.5 × 20	0.20	470	1,175	EKXG201E□□680MK20S
	82	16 × 20	0.20	550	1,375	EKXG201E□□820ML20S
	100	16 × 20	0.20	630	1,420	EKXG201E□□101ML20S
	150	16 × 25	0.20	840	1,890	EKXG201E□□151ML25S
	220	18 × 25	0.20	1,050	2,365	EKXG201E□□221MM25S
	330	18 × 35.5	0.20	1,430	3,220	EKXG201E□□331MMP1S
250	10	10 × 20	0.20	140	350	EKXG251E□□100MJ20S
	22	10 × 20	0.20	200	500	EKXG251E□□220MJ20S
	33	12.5 × 20	0.20	320	800	EKXG251E□□330MK20S
	47	12.5 × 20	0.20	390	975	EKXG251E□□470MK20S
	68	16 × 20	0.20	520	1,300	EKXG251E□□680ML20S
	82	16 × 20	0.20	550	1,375	EKXG251E□□820ML20S
	100	16 × 25	0.20	680	1,530	EKXG251E□□101ML25S
	150	18 × 25	0.20	860	1,935	EKXG251E□□151MM25S
	220	18 × 31.5	0.20	1,130	2,545	EKXG251E□□221MMN3S
350	6.8	10 × 16	0.24	110	275	EKXG351E□□6R8MJ16S
	10	10 × 20	0.24	140	350	EKXG351E□□100MJ20S
	22	12.5 × 20	0.24	260	650	EKXG351E□□220MK20S
	33	16 × 20	0.24	360	900	EKXG351E□□330ML20S
	47	16 × 20	0.24	430	1,075	EKXG351E□□470ML20S
	68	16 × 25	0.24	560	1,400	EKXG351E□□680ML25S
	68	18 × 20	0.24	550	1,375	EKXG351E□□680MM20S
	82	18 × 25	0.24	610	1,525	EKXG351E□□820MM25S
	100	18 × 25	0.24	700	1,575	EKXG351E□□101MM25S
	120	18 × 31.5	0.24	830	1,865	EKXG351E□□121MMN3S
150	18 × 35.5	0.24	960	2,160	EKXG351E□□151MMP1S	
400	6.8	10 × 16	0.24	110	275	EKXG401E□□6R8MJ16S
	10	10 × 20	0.24	140	350	EKXG401E□□100MJ20S
	15	12.5 × 20	0.24	220	550	EKXG401E□□150MK20S
	22	12.5 × 20	0.24	260	650	EKXG401E□□220MK20S
	33	16 × 20	0.24	360	900	EKXG401E□□330ML20S
	47	16 × 25	0.24	470	1,175	EKXG401E□□470ML25S
	47	18 × 20	0.24	450	1,125	EKXG401E□□470MM20S
	68	18 × 25	0.24	585	1,465	EKXG401E□□680MM25S
	82	18 × 25	0.24	610	1,525	EKXG401E□□820MM25S
	100	18 × 31.5	0.24	765	1,720	EKXG401E□□101MMN3S
120	18 × 35.5	0.24	865	1,945	EKXG401E□□121MMP1S	
150	18 × 40	0.24	985	2,215	EKXG401E□□151MM40S	
450	6.8	10 × 20	0.24	110	275	EKXG451E□□6R8MJ20S
	10	12.5 × 20	0.24	180	450	EKXG451E□□100MK20S
	15	12.5 × 25	0.24	240	600	EKXG451E□□150MK25S
	22	16 × 20	0.24	290	725	EKXG451E□□220ML20S
	33	16 × 25	0.24	390	975	EKXG451E□□330ML25S
	33	18 × 20	0.24	380	950	EKXG451E□□330MM20S
	47	18 × 25	0.24	480	1,200	EKXG451E□□470MM25S
	68	18 × 31.5	0.24	630	1,575	EKXG451E□□680MMN3S
	82	18 × 35.5	0.24	715	1,785	EKXG451E□□820MMP1S
	100	18 × 40	0.24	800	1,800	EKXG451E□□101MM40S

□□ : Lead forming / Taping code

# SMH Series

- Downsized from current standard SMG series
- Endurance with ripple current : 2,000 hours at 85°C
- For input filtering of power supplies
- Non solvent-proof type
- RoHS Compliant

SMH

↑ Downsized  
Higher ripple  
Low profile  
SMG



## ◆ SPECIFICATIONS

Items	Characteristics		
Category	-25 to +85°C		
Temperature Range	-25 to +85°C		
Rated Voltage Range	160 to 450V <sub>dc</sub>		
Capacitance Tolerance	±20% (M) (at 20°C, 120Hz)		
Leakage Current	I=0.03CV or 3 mA, whichever is smaller. Where, I : Max. leakage current (μA), C : Nominal capacitance (μF), V : Rated voltage (V) (at 20°C after 5 minutes)		
Dissipation Factor (tanδ)	0.15max. (at 20°C, 120Hz)		
Low Temperature Characteristics (Max. Impedance Ratio)	Rated voltage (V <sub>dc</sub> )	160 to 250V	400 & 450V
	Z(-25°C)/Z(+20°C)	4	6
Endurance	The following specifications shall be satisfied when the capacitors are restored to 20°C after subjected to DC voltage with the rated ripple current is applied for 2,000 hours at 85°C.		
	Capacitance change	≤±20% of the initial value	
	D.F. (tanδ)	≤200% of the initial specified value	
	Leakage current	≤The initial specified value	
Shelf Life	The following specifications shall be satisfied when the capacitors are restored to 20°C after exposing them for 1,000 hours at 85°C without voltage applied.		
	Capacitance change	≤±20% of the initial value	
	D.F. (tanδ)	≤200% of the initial specified value	
	Leakage current	≤500% of the initial specified value	

## ◆ DIMENSIONS [mm]

- Terminal Code : E

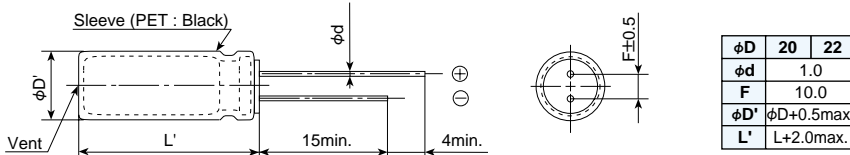

\*Note : The snap-in forming type, RC-type, is available upon request, RC-type fits two φ2mm holes and 10.5mm spacing.

## ◆ PART NUMBERING SYSTEM

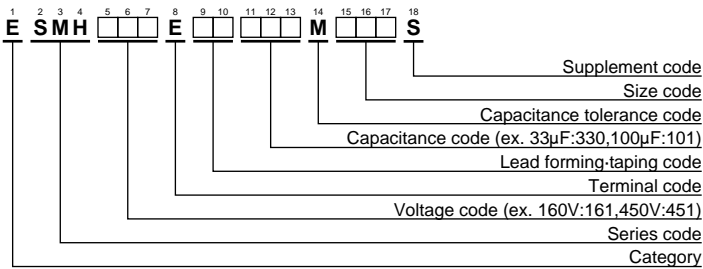

Please refer to "A guide to global code (radial lead type)"

### ◆STANDARD RATINGS

WV (Vdc)	Cap (μF)	Case size φD×L(mm)	tanδ	Rated ripple current (mA <sub>rms</sub> /85°C, 120Hz)	Part No.	WV (Vdc)	Cap (μF)	Case size φD×L(mm)	tanδ	Rated ripple current (mA <sub>rms</sub> /85°C, 120Hz)	Part No.	
160	180	20×20	0.15	900	ESMH161E□□181MN20S	250	330	22×35	0.15	1,710	ESMH251E□□331MP35S	
	180	22×20	0.15	950	ESMH161E□□181MP20S		390	20×45	0.15	1,930	ESMH251E□□391MN45S	
	220	20×25	0.15	1,070	ESMH161E□□221MN25S		390	22×40	0.15	2,000	ESMH251E□□391MP40S	
	220	22×25	0.15	1,160	ESMH161E□□221MP25S		470	20×50	0.15	2,190	ESMH251E□□471MN50S	
	270	20×30	0.15	1,290	ESMH161E□□271MN30S		470	22×45	0.15	2,290	ESMH251E□□471MP45S	
	270	22×25	0.15	1,290	ESMH161E□□271MP25S		400	47	20×20	0.15	480	ESMH401E□□470MN20S
	330	20×30	0.15	1,430	ESMH161E□□331MN30S			56	20×25	0.15	570	ESMH401E□□560MN25S
	330	22×30	0.15	1,530	ESMH161E□□331MP30S			56	22×25	0.15	620	ESMH401E□□560MP25S
	390	20×30	0.15	1,550	ESMH161E□□391MN30S			68	20×25	0.15	640	ESMH401E□□680MN25S
	390	22×30	0.15	1,670	ESMH161E□□391MP30S			68	22×25	0.15	690	ESMH401E□□680MP25S
470	20×35	0.15	1,780	ESMH161E□□471MN35S	82	20×30		0.15	750	ESMH401E□□820MN30S		
470	22×30	0.15	1,830	ESMH161E□□471MP30S	82	22×25		0.15	780	ESMH401E□□820MP25S		
200	150	20×20	0.15	820	ESMH201E□□151MN20S	100		20×35	0.15	870	ESMH401E□□101MN35S	
	150	22×20	0.15	870	ESMH201E□□151MP20S	100		22×30	0.15	900	ESMH401E□□101MP30S	
	180	20×25	0.15	970	ESMH201E□□181MN25S	120		20×40	0.15	1,020	ESMH401E□□121MN40S	
	180	22×25	0.15	1,050	ESMH201E□□181MP25S	120	22×35	0.15	1,030	ESMH401E□□121MP35S		
	220	20×25	0.15	1,070	ESMH201E□□221MN25S	150	20×45	0.15	1,200	ESMH401E□□151MN45S		
	220	22×25	0.15	1,160	ESMH201E□□221MP25S	150	22×40	0.15	1,240	ESMH401E□□151MP40S		
	270	20×30	0.15	1,290	ESMH201E□□271MN30S	180	20×50	0.15	1,360	ESMH401E□□181MN50S		
	270	22×30	0.15	1,390	ESMH201E□□271MP30S	180	22×45	0.15	1,410	ESMH401E□□181MP45S		
	330	20×35	0.15	1,490	ESMH201E□□331MN35S	220	22×50	0.15	1,590	ESMH401E□□221MP50S		
	330	22×30	0.15	1,530	ESMH201E□□331MP30S	450	33	20×20	0.15	400	ESMH451E□□330MN20S	
390	20×35	0.15	1,620	ESMH201E□□391MN35S	47		20×25	0.15	520	ESMH451E□□470MN25S		
390	22×30	0.15	1,670	ESMH201E□□391MP30S	47		22×25	0.15	570	ESMH451E□□470MP25S		
470	20×40	0.15	1,900	ESMH201E□□471MN40S	56		20×30	0.15	620	ESMH451E□□560MN30S		
470	22×35	0.15	1,920	ESMH201E□□471MP35S	56		22×25	0.15	650	ESMH451E□□560MP25S		
250	100	20×20	0.15	670	ESMH251E□□101MN20S		68	20×35	0.15	720	ESMH451E□□680MN35S	
	120	20×25	0.15	850	ESMH251E□□121MN25S		68	22×30	0.15	690	ESMH451E□□680MP30S	
	120	22×20	0.15	830	ESMH251E□□121MP20S		82	20×35	0.15	790	ESMH451E□□820MN35S	
	150	20×25	0.15	940	ESMH251E□□151MN25S		82	22×30	0.15	800	ESMH451E□□820MP30S	
	150	22×25	0.15	1,030	ESMH251E□□151MP25S		100	20×40	0.15	920	ESMH451E□□101MN40S	
	180	20×30	0.15	1,120	ESMH251E□□181MN30S	100	22×35	0.15	940	ESMH451E□□101MP35S		
	180	22×25	0.15	1,120	ESMH251E□□181MP25S	120	20×45	0.15	1,070	ESMH451E□□121MN45S		
	220	20×30	0.15	1,240	ESMH251E□□221MN30S	120	22×40	0.15	1,110	ESMH451E□□121MP40S		
	220	22×30	0.15	1,330	ESMH251E□□221MP30S	150	20×50	0.15	1,240	ESMH451E□□151MN50S		
	270	20×35	0.15	1,440	ESMH251E□□271MN35S	150	22×45	0.15	1,290	ESMH451E□□151MP45S		
270	22×30	0.15	1,470	ESMH251E□□271MP30S	180	22×50	0.15	1,440	ESMH451E□□181MP50S			
330	20×40	0.15	1,700	ESMH251E□□331MN40S								

□□ : Lead forming / Taping code

### ◆RATED RIPPLE CURRENT MULTIPLIERS

#### ●Frequency Multipliers

Frequency (Hz)	50	120	300	1k	10k	50k
160 to 250V <sub>dc</sub>	0.81	1.00	1.17	1.32	1.45	1.50
400 & 450V <sub>dc</sub>	0.77	1.00	1.16	1.30	1.41	1.43

The endurance of capacitors is shorted with internal heating produced by ripple current at the rate of halving the lifetime with every 5°C rise. When long life performance is required in actual use, the rms ripple current has to be reduced.

# KMH Series

- Radial lead type ranging from φ20×20 to φ22×50mm
- For input filtering of power supplies
- Endurance with ripple current : 2,000 hours at 105°C
- Non solvent-proof type
- RoHS Compliant

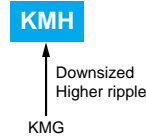

## ◆SPECIFICATIONS

Items	Characteristics		
Category	-25 to +105°C		
Temperature Range	-25 to +105°C		
Rated Voltage Range	160 to 450V <sub>dc</sub>		
Capacitance Tolerance	±20% (M) (at 20°C, 120Hz)		
Leakage Current	I=0.03CV or 3 mA, whichever is smaller. Where, I : Max. leakage current (µA), C : Nominal capacitance (µF), V : Rated voltage (V) (at 20°C after 5 minutes)		
Dissipation Factor (tanδ)	0.15max. (at 20°C, 120Hz)		
Low Temperature Characteristics (Max. Impedance Ratio)	Rated voltage (V <sub>dc</sub> )	160 to 250V	400 & 450V
	Z(-25°C)/Z(+20°C)	4	6
Endurance	The following specifications shall be satisfied when the capacitors are restored to 20°C after subjected to DC voltage with the rated ripple current is applied for 2,000 hours at 105°C.		
	Capacitance change	≤±20% of the initial value	
	D.F. (tanδ)	≤200% of the initial specified value	
	Leakage current	≤The initial specified value	
Shelf Life	The following specifications shall be satisfied when the capacitors are restored to 20°C after exposing them for 1,000 hours at 105°C without voltage applied.		
	Capacitance change	≤±20% of the initial value	
	D.F. (tanδ)	≤200% of the initial specified value	
	Leakage current	≤500% of the initial specified value	

## ◆DIMENSIONS [mm]

- Terminal Code : E

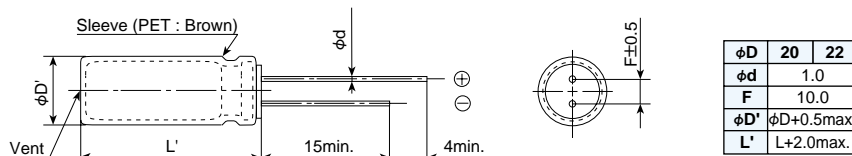

\*Note : The snap-in forming type, RC-type, is available upon request, RC-type fits two φ2mm holes and 10.5mm spacing.

## ◆PART NUMBERING SYSTEM

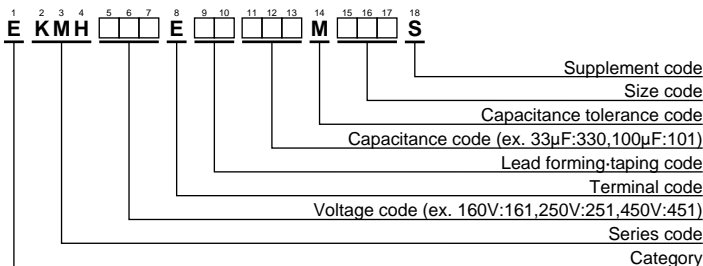

Please refer to "A guide to global code (radial lead type)"

### ◆STANDARD RATINGS

WV (Vdc)	Cap (μF)	Case size φD×L(mm)	tanδ	Rated ripple current (mA <sub>rms</sub> /105°C, 120Hz)	Part No.	WV (Vdc)	Cap (μF)	Case size φD×L(mm)	tanδ	Rated ripple current (mA <sub>rms</sub> /105°C, 120Hz)	Part No.
160	150	20×20	0.15	580	EKMH161E□□151MN20S	250	220	22×30	0.15	950	EKMH251E□□221MP30S
	180	20×25	0.15	690	EKMH161E□□181MN25S		270	20×40	0.15	1,090	EKMH251E□□271MN40S
	180	22×20	0.15	680	EKMH161E□□181MP20S		270	22×35	0.15	1,140	EKMH251E□□271MP35S
	220	20×25	0.15	760	EKMH161E□□221MN25S		330	20×45	0.15	1,260	EKMH251E□□331MN45S
	220	22×25	0.15	820	EKMH161E□□221MP25S		330	22×40	0.15	1,300	EKMH251E□□331MP40S
	270	20×30	0.15	910	EKMH161E□□271MN30S		390	20×50	0.15	1,410	EKMH251E□□391MN50S
	270	22×25	0.15	910	EKMH161E□□271MP25S		390	22×45	0.15	1,490	EKMH251E□□391MP45S
	330	20×30	0.15	1,010	EKMH161E□□331MN30S		470	22×50	0.15	1,650	EKMH251E□□471MP50S
	330	22×30	0.15	1,160	EKMH161E□□331MP30S	400	33	20×20	0.15	290	EKMH401E□□330MN20S
	390	20×35	0.15	1,150	EKMH161E□□391MN35S		47	22×20	0.15	370	EKMH401E□□470MP20S
	390	22×30	0.15	1,270	EKMH161E□□391MP30S		56	20×25	0.15	410	EKMH401E□□560MN25S
	470	20×40	0.15	1,340	EKMH161E□□471MN40S		68	20×30	0.15	490	EKMH401E□□680MN30S
470	22×35	0.15	1,400	EKMH161E□□471MP35S	68		22×25	0.15	510	EKMH401E□□680MP25S	
200	120	20×20	0.15	520	EKMH201E□□121MN20S		100	20×35	0.15	620	EKMH401E□□101MN35S
	150	20×25	0.15	630	EKMH201E□□151MN25S		100	22×30	0.15	640	EKMH401E□□101MP30S
	150	22×20	0.15	620	EKMH201E□□151MP20S		120	20×40	0.15	720	EKMH401E□□121MN40S
	180	20×25	0.15	690	EKMH201E□□181MN25S		120	22×35	0.15	730	EKMH401E□□121MP35S
	180	22×25	0.15	750	EKMH201E□□181MP25S		150	20×45	0.15	850	EKMH401E□□151MN45S
	220	20×30	0.15	820	EKMH201E□□221MN30S		150	22×40	0.15	880	EKMH401E□□151MP40S
	220	22×25	0.15	820	EKMH201E□□221MP25S		180	20×50	0.15	960	EKMH401E□□181MN50S
	270	20×30	0.15	910	EKMH201E□□271MN30S	180	22×45	0.15	990	EKMH401E□□181MP45S	
	270	22×30	0.15	980	EKMH201E□□271MP30S	220	22×50	0.15	1,130	EKMH401E□□221MP50S	
	330	20×35	0.15	1,050	EKMH201E□□331MN35S	450	33	20×25	0.15	310	EKMH451E□□330MN25S
	330	22×35	0.15	1,200	EKMH201E□□331MP35S		47	22×25	0.15	420	EKMH451E□□470MP25S
	390	20×40	0.15	1,220	EKMH201E□□391MN40S		56	20×30	0.15	440	EKMH451E□□560MN30S
390	22×35	0.15	1,310	EKMH201E□□391MP35S	68		20×35	0.15	510	EKMH451E□□680MN35S	
470	20×45	0.15	1,340	EKMH201E□□471MN45S	68		22×30	0.15	520	EKMH451E□□680MP30S	
470	22×40	0.15	1,450	EKMH201E□□471MP40S	82		20×40	0.15	600	EKMH451E□□820MN40S	
250	82	20×20	0.15	460	EKMH251E□□820MN20S		82	22×35	0.15	600	EKMH451E□□820MP35S
	120	20×25	0.15	600	EKMH251E□□121MN25S		100	20×45	0.15	690	EKMH451E□□101MN45S
	120	22×20	0.15	590	EKMH251E□□121MP20S		100	22×40	0.15	710	EKMH451E□□101MP40S
	180	20×30	0.15	790	EKMH251E□□181MN30S		120	20×50	0.15	780	EKMH451E□□121MN50S
	180	22×25	0.15	790	EKMH251E□□181MP25S		120	22×45	0.15	810	EKMH451E□□121MP45S
	220	20×35	0.15	920	EKMH251E□□221MN35S		150	22×50	0.15	930	EKMH451E□□151MP50S

□□ : Lead forming / Taping code

### ◆RATED RIPPLE CURRENT MULTIPLIERS

●Frequency Multipliers

Frequency (Hz)	50	120	300	1k	10k	50k
160 to 250V <sub>dc</sub>	0.81	1.00	1.17	1.32	1.45	1.50
400 & 450V <sub>dc</sub>	0.77	1.00	1.16	1.30	1.41	1.43

The endurance of capacitors is shorted with internal heating produced by ripple current at the rate of halving the lifetime with every 5°C rise. When long life performance is required in actual use, the rms ripple current has to be reduced.



# PAG Series

- Downsize, high ripple design (φ10 to 18)
- Rated voltage range : 200 to 450V<sub>dc</sub>, Capacitance range : 18 to 560μF
- Endurance with ripple current : 2,000 hours at 105°C
- Ideal for low profile power supply application
- Non solvent-proof type
- RoHS Compliant

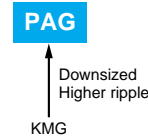

## ◆SPECIFICATIONS

Items	Characteristics				
Category	—40 to +105°C (200, 400V <sub>dc</sub> ) —25 to +105°C (420, 450V <sub>dc</sub> )				
Temperature Range					
Rated Voltage Range	200 to 450V <sub>dc</sub>				
Capacitance Tolerance	±20% (M) (at 20°C, 120Hz)				
Leakage Current		After 1 minute		After 5 minutes	
	CV ≤ 1,000	I = 0.1CV + 40		I = 0.03CV + 15	
	CV > 1,000	I = 0.04CV + 100		I = 0.02CV + 25	
	Where, I : Max. leakage current (μA), C : Nominal capacitance (μF), V : Rated voltage (V) (at 20°C)				
Dissipation Factor (tanδ)	Rated voltage (V <sub>dc</sub> )	200V	400V	420V	450V
	tanδ (Max.)	0.12	0.15	0.20	0.20
	(at 20°C, 120Hz)				
Low Temperature Characteristics (Max. Impedance Ratio)	Rated voltage (V <sub>dc</sub> )	200V	400V	420V	450V
	Z(-25°C)/Z(+20°C)	3	5	6	6
	Z(-40°C)/Z(+20°C)	6	6	—	—
	(at 120Hz)				
Endurance	The following specifications shall be satisfied when the capacitors are restored to 20°C after subjected to DC voltage with the rated ripple current is applied for 2,000 hours at 105°C.				
	Capacitance change	≤ ±20% of the initial value			
	D.F. (tanδ)	≤ 200% of the initial specified value			
	Leakage current	≤ The initial specified value			
Shelf Life	The following specifications shall be satisfied when the capacitors are restored to 20°C after exposing them for 1,000 hours at 105°C without voltage applied.				
	Capacitance change	≤ ±20% of the initial value			
	D.F. (tanδ)	≤ 200% of the initial specified value			
	Leakage current	≤ 500% of the initial specified value			

## ◆DIMENSIONS [mm]

- Terminal Code : E

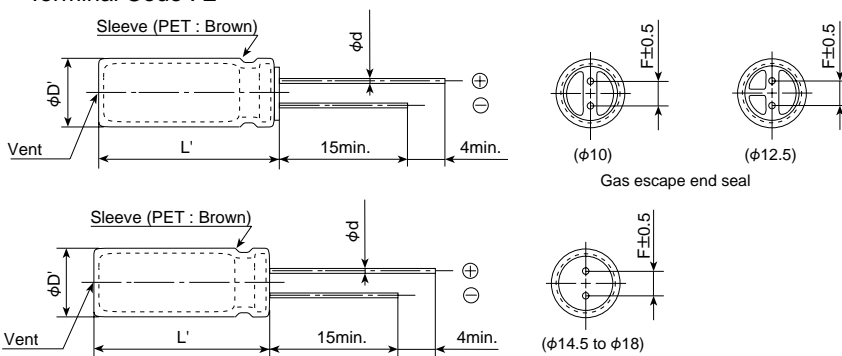

φD	10	12.5	14.5	16	18
φd	0.6	0.6	0.8	0.8	0.8
F	5.0	5.0	7.5	7.5	7.5
φD'	φD+0.5 max.				
L'	L+2.0 max.				

## ◆PART NUMBERING SYSTEM

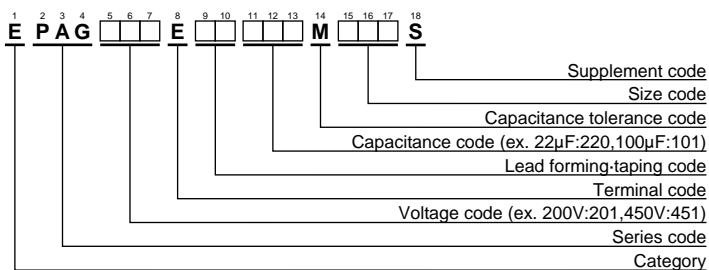

Please refer to "A guide to global code (radial lead type)"

**◆STANDARD RATINGS**

WV (V <sub>dc</sub> )	Cap (μF)	Case size φD×L(mm)	tanδ	Rated ripple current (mA <sub>rms</sub> /105°C,120Hz)	Part No.	WV (V <sub>dc</sub> )	Cap (μF)	Case size φD×L(mm)	tanδ	Rated ripple current (mA <sub>rms</sub> /105°C,120Hz)	Part No.
200	82	10×30	0.12	440	EPAG201E□□820MJ30S	420	22	10×30	0.20	230	EPAG421E□□220MJ30S
	100	10×35	0.12	510	EPAG201E□□101MJ35S		27	10×35	0.20	270	EPAG421E□□270MJ35S
	120	10×40	0.12	590	EPAG201E□□121MJ40S		33	10×40	0.20	310	EPAG421E□□330MJ40S
	150	12.5×30	0.12	650	EPAG201E□□151MK30S		39	12.5×30	0.20	330	EPAG421E□□390MK30S
	180	12.5×35	0.12	750	EPAG201E□□181MK35S		47	12.5×35	0.20	390	EPAG421E□□470MK35S
	220	12.5×40	0.12	830	EPAG201E□□221MK40S		56	12.5×40	0.20	430	EPAG421E□□560MK40S
	220	14.5×30	0.12	830	EPAG201E□□221MU30S		56	14.5×30	0.20	430	EPAG421E□□560MU30S
	270	14.5×35	0.12	960	EPAG201E□□271MJ35S		68	14.5×35	0.20	510	EPAG421E□□680MJ35S
	270	16×30	0.12	960	EPAG201E□□271ML30S		68	16×30	0.20	510	EPAG421E□□680ML30S
	330	16×35	0.12	1,100	EPAG201E□□331ML35S		82	14.5×40	0.20	570	EPAG421E□□820MU40S
	330	18×30	0.12	1,100	EPAG201E□□331MM30S		82	16×35	0.20	570	EPAG421E□□820ML35S
	390	16×40	0.12	1,240	EPAG201E□□391ML40S		100	16×40	0.20	610	EPAG421E□□101ML40S
	390	18×35	0.12	1,240	EPAG201E□□391MM35S		100	18×30	0.20	610	EPAG421E□□101MM30S
	470	18×40	0.12	1,390	EPAG201E□□471MM40S		120	18×35	0.20	690	EPAG421E□□121MM35S
560	18×45	0.12	1,560	EPAG201E□□561MM45S	150	18×40	0.20	790	EPAG421E□□151MM40S		
400	27	10×30	0.15	260	EPAG401E□□270MJ30S	450	18	10×30	0.20	210	EPAG451E□□180MJ30S
	33	10×35	0.15	300	EPAG401E□□330MJ35S		22	10×35	0.20	240	EPAG451E□□220MJ35S
	39	10×40	0.15	340	EPAG401E□□390MJ40S		27	10×40	0.20	280	EPAG451E□□270MJ40S
	47	12.5×30	0.15	370	EPAG401E□□470MK30S		33	12.5×30	0.20	310	EPAG451E□□330MK30S
	56	12.5×35	0.15	420	EPAG401E□□560MK35S		39	12.5×35	0.20	350	EPAG451E□□390MK35S
	68	12.5×40	0.15	480	EPAG401E□□680MK40S		47	12.5×40	0.20	390	EPAG451E□□470MK40S
	68	14.5×30	0.15	480	EPAG401E□□680MU30S		47	14.5×30	0.20	390	EPAG451E□□470MU30S
	82	14.5×35	0.15	530	EPAG401E□□820MU35S		56	14.5×35	0.20	440	EPAG451E□□560MU35S
	100	14.5×40	0.15	580	EPAG401E□□101MU40S		56	16×30	0.20	440	EPAG451E□□560ML30S
	100	16×30	0.15	580	EPAG401E□□101ML30S		68	14.5×40	0.20	500	EPAG451E□□680MU40S
	120	16×35	0.15	670	EPAG401E□□121ML35S		68	16×35	0.20	500	EPAG451E□□680ML35S
	120	18×30	0.15	670	EPAG401E□□121MM30S		82	16×40	0.20	550	EPAG451E□□820ML40S
	150	16×40	0.15	770	EPAG401E□□151ML40S		82	18×30	0.20	550	EPAG451E□□820MM30S
	150	18×35	0.15	770	EPAG401E□□151MM35S		100	18×35	0.20	650	EPAG451E□□101MM35S
180	18×40	0.15	880	EPAG401E□□181MM40S	120	18×40	0.20	740	EPAG451E□□121MM40S		
220	18×45	0.15	1,000	EPAG401E□□221MM45S	150	18×45	0.20	810	EPAG451E□□151MM45S		

□□ : Lead forming / Taping code

**◆RATED RIPPLE CURRENT MULTIPLIERS**

## ●Frequency Multipliers

Capacitance (μF)	Frequency (Hz)			
	120	1k	10k	100k
18 to 82	1.00	1.50	1.75	1.80
100 to 560	1.00	1.30	1.40	1.50

The endurance of capacitors is shortened with internal heating produced by ripple current at the rate of halving the lifetime with every 5°C rise. When long life performance is required in actual use, the rms ripple current has to be reduced.

New!

KLJ Series

- No sparks against DC over-voltage
- Endurance with ripple current : 2,000 hours at 105°C
- Non solvent-proof type
- Prescribe the ESR value
- RoHS Compliant

KLJ

Downsized

KLJ



◆ SPECIFICATIONS

Items	Characteristics		
Category Temperature Range	-25 to +105°C		
Rated Voltage Range	200 & 400V <sub>dc</sub>		
Capacitance Tolerance	±20% (M) (at 20°C, 120Hz)		
Leakage Current	I=0.04CV+100 Where, I : Max. leakage current (μA), C : Nominal capacitance (μF), V : Rated voltage (V) (at 20°C after 1 minute)		
Dissipation Factor (tanδ)	Rated voltage (V <sub>dc</sub> )	200V	400V
	tanδ (Max.)	0.20	0.24
Low Temperature Characteristics (Max. Impedance Ratio)	Rated voltage (V <sub>dc</sub> )	200V	400V
	Z(-25°C)/Z(+20°C)	4	6
Endurance	The following specifications shall be satisfied when the capacitors are restored to 20°C after subjected to DC voltage with the rated ripple current is applied for 2,000 hours at 105°C.		
	Capacitance change	≤±20% of the initial value	
	D.F. (tanδ)	≤200% of the initial specified value	
	Leakage current	≤The initial specified value	
Shelf Life	The following specifications shall be satisfied when the capacitors are restored to 20°C after exposing them for 1,000 hours at 105°C without voltage applied.		
	Capacitance change	≤±20% of the initial value	
	D.F. (tanδ)	≤200% of the initial specified value	
	Leakage current	≤500% of the initial specified value	

◆ DIMENSIONS [mm]

- Terminal Code : E

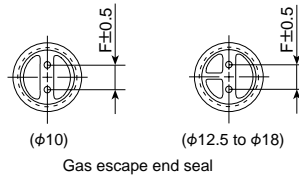
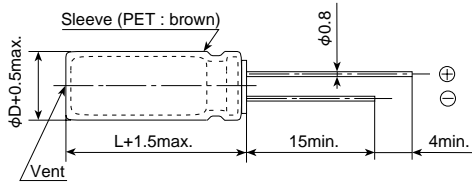

φD	10	12.5	16	18
φd	0.6	0.6	0.8	0.8
F	5.0	5.0	7.5	7.5
φD'	φD+0.5max.			
L'	L+1.5max.			

◆ PART NUMBERING SYSTEM

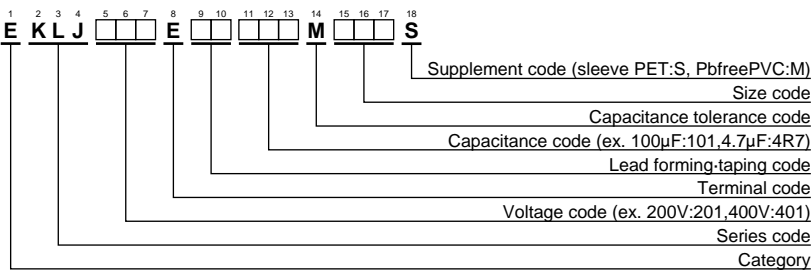

Please refer to "A guide to global code (radial lead type)"

◆STANDARD RATINGS

WV (Vdc)	Cap (μF)	Case size φDXL(mm)	tanδ	ESR (Ωmax/20°C, 100kHz)	Rated ripple current (mA <sub>rms</sub> /105°C, 120Hz)	Part No.
200	33	10×20	0.20	1.8	165	EKLJ201E□□330MJ20S
	39	10×25	0.20	1.4	200	EKLJ201E□□390MJ25S
	56	12.5×20	0.20	1.0	265	EKLJ201E□□560MK20S
	82	12.5×25	0.20	0.72	350	EKLJ201E□□820MK25S
	100	16×20	0.20	0.63	390	EKLJ201E□□101ML20S
	120	16×25	0.20	0.44	465	EKLJ201E□□121ML25S
	150	18×20	0.20	0.31	505	EKLJ201E□□151MM20S
	180	16×31.5	0.20	0.36	615	EKLJ201E□□181MLN3S
	180	18×25	0.20	0.30	585	EKLJ201E□□181MM25S
	220	16×35.5	0.20	0.30	695	EKLJ201E□□221MLP1S
	220	18×31.5	0.20	0.28	700	EKLJ201E□□221MMN3S
270	18×35.5	0.20	0.24	805	EKLJ201E□□271MMP1S	
330	18×40	0.20	0.21	900	EKLJ201E□□331MM40S	
400	4.7	10×12.5	0.24	8.4	36	EKLJ401E□□4R7MJC5S
	10	10×16	0.24	5.7	64	EKLJ401E□□100MJ16S
	15	10×20	0.24	4.0	105	EKLJ401E□□150MJ20S
	18	10×25	0.24	3.2	110	EKLJ401E□□180MJ25S
	22	12.5×20	0.24	2.7	165	EKLJ401E□□220MK20S
	27	12.5×25	0.24	1.9	200	EKLJ401E□□270MK25S
	33	16×20	0.24	1.5	225	EKLJ401E□□330ML20S
	39	18×20	0.24	1.2	255	EKLJ401E□□390MM20S
	39	18×25	0.24	0.72	270	EKLJ401E□□390MM25S
	47	16×25	0.24	1.1	290	EKLJ401E□□470ML25S
	47	18×20	0.24	1.2	280	EKLJ401E□□470MM20S
	56	16×31.5	0.24	0.84	340	EKLJ401E□□560MLN3S
	68	16×35.5	0.24	0.72	385	EKLJ401E□□680MLP1S
	68	18×25	0.24	0.88	360	EKLJ401E□□680MM25S
	82	16×40	0.24	0.65	435	EKLJ401E□□820ML40S
	82	18×31.5	0.24	0.64	425	EKLJ401E□□820MMN3S
100	18×35.5	0.24	0.54	490	EKLJ401E□□101MMP1S	
120	18×40	0.24	0.49	540	EKLJ401E□□121MM40S	

□□ : Lead forming / Taping code

Sleeve PET : suffix is S, PbfreePVC : suffix is M

◆DC OVERVOLTAGE TEST CONDITIONS

The vent will be operated and the capacitor shall become an open circuit without burning materials when the following excess DC voltage is applied.

●Test DC voltage

Rated voltage	Current limit	Test DC voltage
200V <sub>dc</sub>	4A	300/375V <sub>dc</sub>
400V <sub>dc</sub>	2A	500/600V <sub>dc</sub>

●Test circuit

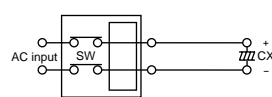

Constant DC voltage/current power supply

◆RATED RIPPLE CURRENT MULTIPLIERS

●Frequency Multipliers

Frequency (Hz)	50	120	300	1k	10k	50k	100k
4.7 to 10μF	0.65	1.00	1.35	1.75	2.30	2.50	2.70
15 to 47μF	0.75	1.00	1.25	1.50	1.75	1.80	1.85
56 to 330μF	0.80	1.00	1.15	1.30	1.40	1.50	1.60

The endurance of capacitors is shortened with internal heating produced by ripple current at the rate of halving the lifetime with every 5°C rise.

When long life performance is required in actual use, the rms ripple current has to be reduced.

# KLG Series

- No sparks against DC over-voltage
- Endurance with ripple current : 2,000 hours at 105°C
- Non solvent-proof type
- RoHS Compliant

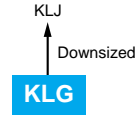

## ◆ SPECIFICATIONS

Items	Characteristics	
<b>Category</b> Temperature Range	-25 to +105°C	
<b>Rated Voltage Range</b>	200 & 400V <sub>dc</sub>	
<b>Capacitance Tolerance</b>	±20% (M) (at 20°C, 120Hz)	
<b>Leakage Current</b>	I=0.04CV+100 Where, I : Max. leakage current (μA), C : Nominal capacitance (μF), V : Rated voltage (V) (at 20°C after 1 minute)	
<b>Dissipation Factor (tanδ)</b>	Rated voltage (V <sub>dc</sub> )	200V 400V
	tanδ (Max.)	0.20 0.24 (at 20°C, 120Hz)
<b>Low Temperature Characteristics (Max. Impedance Ratio)</b>	Rated voltage (V <sub>dc</sub> )	200V 400V
	Z(-25°C)/Z(+20°C)	4 6 (at 120Hz)
<b>Endurance</b>	The following specifications shall be satisfied when the capacitors are restored to 20°C after subjected to DC voltage with the rated ripple current is applied for 2,000 hours at 105°C.	
	Capacitance change	≤±20% of the initial value
	D.F. (tanδ)	≤200% of the initial specified value
	Leakage current	≤The initial specified value
<b>Shelf Life</b>	The following specifications shall be satisfied when the capacitors are restored to 20°C after exposing them for 1,000 hours at 105°C without voltage applied.	
	Capacitance change	≤±20% of the initial value
	D.F. (tanδ)	≤200% of the initial specified value
	Leakage current	≤500% of the initial specified value

## ◆ DIMENSIONS [mm]

- Terminal Code : E

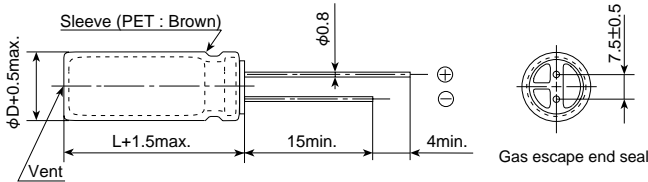

## ◆ PART NUMBERING SYSTEM

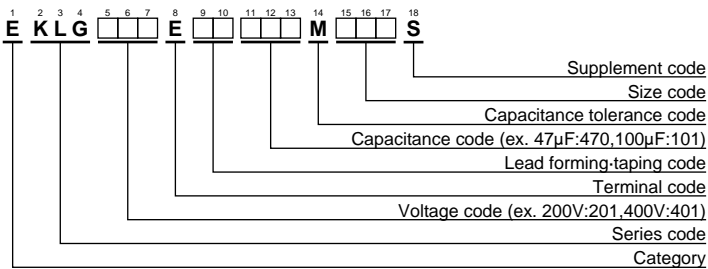

Please refer to "A guide to global code (radial lead type)"

◆STANDARD RATINGS

WV (V <sub>dc</sub> )	Cap (μF)	Case size φD×L(mm)	tanδ	Rated ripple current (mA <sub>rms</sub> /105°C,120Hz)	Part No.	WV (V <sub>dc</sub> )	Cap (μF)	Case size φD×L(mm)	tanδ	Rated ripple current (mA <sub>rms</sub> /105°C,120Hz)	Part No.
200	82	16×20	0.20	230	EKLG201E□□820ML20S	400	22	16×20	0.24	145	EKLG401E□□220ML20S
	100	16×25	0.20	425	EKLG201E□□101ML25S		22	16×25	0.24	200	EKLG401E□□220ML25S
	100	18×20	0.20	250	EKLG201E□□101MM20S		33	16×25	0.24	220	EKLG401E□□330ML25S
	120	16×31.5	0.20	500	EKLG201E□□121MLN3S		33	18×20	0.24	225	EKLG401E□□330MM20S
	120	18×25	0.20	475	EKLG201E□□121MM25S		39	16×31.5	0.24	245	EKLG401E□□390MLN3S
	130	18×20	0.20	285	EKLG201E□□131MM20S		39	18×25	0.24	250	EKLG401E□□390MM25S
	150	16×31.5	0.20	560	EKLG201E□□151MLN3S		47	16×31.5	0.24	275	EKLG401E□□470MLN3S
	150	18×20	0.20	315	EKLG201E□□151MM20S		47	18×25	0.24	280	EKLG401E□□470MM25S
	150	18×25	0.20	530	EKLG201E□□151MM25S		56	16×40	0.24	350	EKLG401E□□560ML40S
	180	16×40	0.20	645	EKLG201E□□181ML40S		56	18×31.5	0.24	315	EKLG401E□□560MMN3S
	180	18×31.5	0.20	630	EKLG201E□□181MMN3S		68	18×35.5	0.24	350	EKLG401E□□680MMP1S
	220	18×35.5	0.20	725	EKLG201E□□221MMP1S		82	18×40	0.24	395	EKLG401E□□820MM40S
	220	18×40	0.20	735	EKLG201E□□221MM40S		100	18×40	0.24	450	EKLG401E□□101MM40S
	270	18×45	0.20	830	EKLG201E□□271MM45S						
330	18×45	0.20	920	EKLG201E□□331MM45S							

□□ : Lead forming / Taping code

◆DC OVERVOLTAGE TEST CONDITIONS

The vent will be operated and the capacitor shall become an open circuit without burning materials when the following excess DC voltage is applied.

●Test DC voltage

Rated voltage	Current limit	Test DC voltage
200V <sub>dc</sub>	4A	300/375V <sub>dc</sub>
400V <sub>dc</sub>	2A	500/600V <sub>dc</sub>

●Test circuit

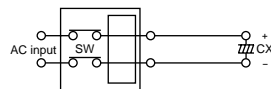

Constant DC voltage/current power supply

◆RATED RIPPLE CURRENT MULTIPLIERS

●Frequency Multipliers

Frequency (Hz)	50	120	300	1k	10k	50k	100k
22 to 47μF	0.75	1.00	1.25	1.50	1.75	1.80	1.85
56 to 330μF	0.80	1.00	1.15	1.30	1.40	1.50	1.60

The endurance of capacitors is shortened with internal heating produced by ripple current at the rate of halving the lifetime with every 5°C rise. When long life performance is required in actual use, the rms ripple current has to be reduced.

**FL Series**

- Long life and high reliability for  $\phi 4 \times 5L$  to  $\phi 8 \times 7L$  mm range
- Endurance with ripple current : 3,000 hours at 105°C
- Suitable for long life and high reliability required products
- Solvent-proof type (see PRECAUTIONS AND GUIDELINES)
- RoHS Compliant

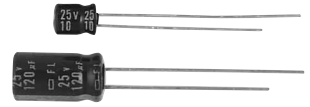

◆ SPECIFICATIONS

Items	Characteristics	
Category Temperature Range	-40 to +105°C	
Rated Voltage Range	6.3 to 50V <sub>dc</sub>	
Capacitance Tolerance	±20% (M) (at 20°C, 120Hz)	
Leakage Current	I=0.03CV or 3µA, whichever is greater. Where, I : Max. leakage current (µA), C : Nominal capacitance (µF), V : Rated voltage (V) (at 20°C after 2 minutes)	
Dissipation Factor (tanδ)	Rated voltage (V <sub>dc</sub> )	6.3V 10V 16V 25V 35V 50V tanδ (Max.) 0.50 0.40 0.35 0.30 0.25 0.25 (at 20°C, 120Hz)
Endurance	The following specifications shall be satisfied when the capacitors are restored to 20°C after subjected to DC voltage with the rated ripple current is applied for 3,000 hours at 105°C.	
	Capacitance change	≤±30% of the initial value
	D.F. (tanδ)	≤300% of the initial specified value
	Leakage current	≤The initial specified value
Shelf Life	The following specifications shall be satisfied when the capacitors are restored to 20°C after exposing them for 1,000 hours at 105°C without voltage applied.	
	Capacitance change	≤±20% of the initial value
	D.F. (tanδ)	≤200% of the initial specified value
	Leakage current	≤The initial specified value

◆ DIMENSIONS [mm]

- Terminal Code : E

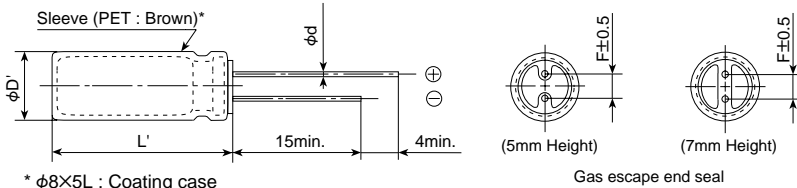

\*  $\phi 8 \times 5L$  : Coating case

Gas escape end seal

5mm Height

φD	4	5	6.3	8
φd	0.45	0.45	0.45	0.45
F	1.5	2.0	2.5	2.5
φD'	φD+0.5max.			
L'	L+1.0max.			

7mm Height

φD	4	5	6.3	8
φd	0.45	0.45	0.45	0.45
F	1.5	2.0	2.5	3.5
φD'	φD+0.5max.			
L'	L+1.0max.			

◆ PART NUMBERING SYSTEM

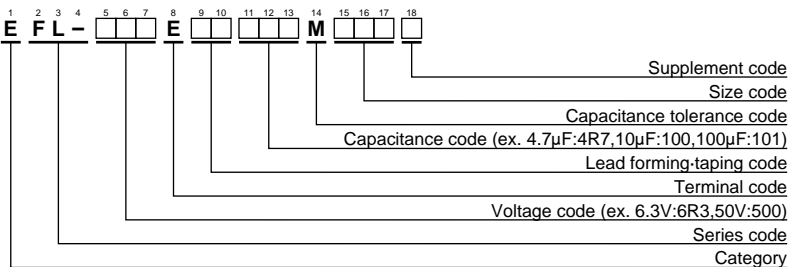

Please refer to "A guide to global code (radial lead type)"

**◆STANDARD RATINGS**

WV (Vdc)	Cap (μF)	Case size φDXL(mm)	tanδ	Impedance (Ωmax/20°C, 100kHz)	Rated ripple current (mArms/105°C,100kHz)	Part No.
6.3	33	4×5	0.50	5.4	37	EFL-6R3E□□330MD05D
	47	4×7	0.50	4.5	44	EFL-6R3E□□470MD07D
	56	5×5	0.50	3.1	57	EFL-6R3E□□560ME05D
	82	5×7	0.50	2.5	70	EFL-6R3E□□820ME07D
	100	6.3×5	0.50	1.7	82	EFL-6R3E□□101MF05D
	150	6.3×7	0.50	1.3	116	EFL-6R3E□□151MF07D
	220	8×5	0.50	1.5	110	EFL-6R3E□□221MH05G
270	8×7	0.50	0.90	162	EFL-6R3E□□271MH07D	
10	22	4×5	0.40	5.4	37	EFL-100E□□220MD05D
	33	4×7	0.40	4.5	44	EFL-100E□□330MD07D
	33	5×5	0.40	3.1	57	EFL-100E□□330ME05D
	47	5×7	0.40	2.5	70	EFL-100E□□470ME07D
	68	6.3×5	0.40	1.7	82	EFL-100E□□680MF05D
	100	6.3×7	0.40	1.3	116	EFL-100E□□101MF07D
	150	8×5	0.40	1.5	110	EFL-100E□□151MH05G
220	8×7	0.40	0.90	162	EFL-100E□□221MH07D	
16	15	4×5	0.35	5.4	37	EFL-160E□□150MD05D
	22	4×7	0.35	4.5	44	EFL-160E□□220MD07D
	22	5×5	0.35	3.1	57	EFL-160E□□220ME05D
	33	5×7	0.35	2.5	70	EFL-160E□□330ME07D
	47	6.3×5	0.35	1.7	82	EFL-160E□□470MF05D
	68	6.3×7	0.35	1.3	116	EFL-160E□□680MF07D
	100	8×5	0.35	1.5	110	EFL-160E□□101MH05G
150	8×7	0.35	0.90	162	EFL-160E□□151MH07D	
25	10	4×5	0.30	5.4	37	EFL-250E□□100MD05D
	15	4×7	0.30	4.5	44	EFL-250E□□150MD07D
	15	5×5	0.30	3.1	57	EFL-250E□□150ME05D
	22	5×7	0.30	2.5	70	EFL-250E□□220ME07D
	33	6.3×5	0.30	1.7	82	EFL-250E□□330MF05D
	56	6.3×7	0.30	1.3	116	EFL-250E□□560MF07D
	68	8×5	0.30	1.5	110	EFL-250E□□680MH05G
100	8×7	0.30	0.90	162	EFL-250E□□101MH07D	
35	4.7	4×5	0.25	5.4	37	EFL-350E□□4R7MD05D
	6.8	4×7	0.25	4.5	44	EFL-350E□□6R8MD07D
	10	5×5	0.25	3.1	57	EFL-350E□□100ME05D
	10	5×7	0.25	2.5	70	EFL-350E□□100ME07D
	22	6.3×5	0.25	1.7	82	EFL-350E□□220MF05D
	22	6.3×7	0.25	1.3	116	EFL-350E□□220MF07D
	33	8×5	0.25	1.5	110	EFL-350E□□330MH05G
47	8×7	0.25	0.90	162	EFL-350E□□470MH07D	
50	0.47	4×5	0.25	34	14	EFL-500E□□R47MD05D
	1	4×5	0.25	19	18	EFL-500E□□1R0MD05D
	2.2	4×5	0.25	14	22	EFL-500E□□2R2MD05D
	3.3	4×5	0.25	11	26	EFL-500E□□3R3MD05D
	4.7	4×7	0.25	9.0	30	EFL-500E□□4R7MD07D
	4.7	5×5	0.25	6.0	40	EFL-500E□□4R7ME05D
	6.8	5×7	0.25	4.8	50	EFL-500E□□6R8ME07D
	10	6.3×5	0.25	2.9	63	EFL-500E□□100MF05D
	15	6.3×7	0.25	2.2	90	EFL-500E□□150MF07D
	22	8×5	0.25	2.6	84	EFL-500E□□220MH05G
22	8×7	0.25	1.6	120	EFL-500E□□220MH07D	

□ □ : Lead forming / Taping code

**◆RATED RIPPLE CURRENT MULTIPLIERS**

## ●Frequency Multipliers

Capacitance(μF)	Frequency(Hz)	120	1k	10k	100k
to 3.3		0.20	0.66	0.90	1.00
	to 3.3	0.20	0.66	0.90	1.00
4.7 to 6.8		0.35	0.70	0.90	1.00
10 to 150		0.40	0.75	0.90	1.00
220 to 270		0.50	0.85	0.94	1.00

The endurance of capacitors is shorted with internal heating produced by ripple current at the rate of halving the lifetime with every 5°C rise. When long life performance is required in actual use, the rms ripple current has to be reduced.



New! **GPA Series**

- Downsized, low impedance and High-Ripple Current version of GXE series
- For automobile modules and other high temperature applications
- Endurance with ripple current : 3,000 to 5,000 hours at 125°C
- High heat-resistance at 150°C
- Solvent-proof type
- RoHS Compliant

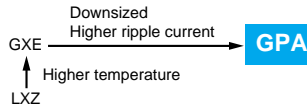

◆ SPECIFICATIONS

Items	Characteristics				
Category	-40 to +125°C				
Temperature Range	-40 to +125°C				
Rated Voltage Range	25 to 63V <sub>dc</sub>				
Capacitance Tolerance	±20% (M) (at 20°C, 120Hz)				
Leakage Current	I=0.03CV or 4μA, whichever is greater. (at 20°C, 1 minute) Where, I : Max. leakage current (μA), C : Nominal capacitance (μF), V : Rated voltage (V)				
Dissipation Factor (tanδ)	Rated voltage (V <sub>dc</sub> )	25	35	50	63
	tanδ (Max.)	0.14	0.12	0.10	0.10
	When nominal capacitance exceeds 1,000μF, add 0.02 to the above value for each 1,000μF increase. (at 20°C, 120Hz)				
Low Temperature Characteristics (Max. Impedance Ratio)	Rated voltage (V <sub>dc</sub> )	25	35	50	63
	Z(-25°C)/Z(+20°C)	2	2	2	2
	Z(-40°C)/Z(+20°C)	4	4	4	4
Endurance1	The following specifications shall be satisfied when the capacitors are restored to 20°C after subjected to DC voltage with the rated ripple current is applied for 5,000 hours (3,000 hours for 25L and less) at 125°C.				
	Capacitance change	≤±30% of the initial value			
	D.F. (tanδ)	≤±300% of the initial specified value			
	Leakage current	≤The initial specified value			
Endurance2	The following specifications shall be satisfied when the capacitors are restored to 20°C after the test condition that be exposed them for 500 hours (250 hours for 25L and less) at 150°C without voltage applied and DC voltage with the rated ripple current is applied for 3,600 hours (2,300 hours for 25L and less) at 125°C.				
	Capacitance change	≤±30% of the initial value			
	D.F. (tanδ)	≤±300% of the initial specified value			
	Leakage current	≤The initial specified value			
Shelf Life	The following specifications shall be satisfied when the capacitors are restored to 20°C after exposing them for 1,000 hours at 125°C without voltage applied.				
	Capacitance change	≤±30% of the initial value			
	D.F. (tanδ)	≤±300% of the initial specified value			
	Leakage current	≤The initial specified value			

◆ DIMENSIONS [mm]

- Terminal Code : E

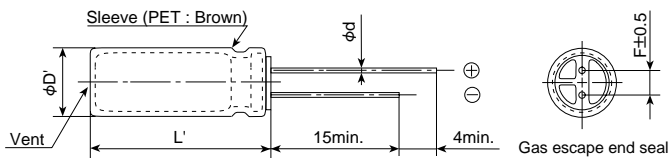

φD	12.5	14.5	16	18
φd	0.6	0.8	0.8	0.8
F	5.0	7.5	7.5	7.5
φD'	φD+0.5max.			
L'	L+1.5max.			

◆ PART NUMBERING SYSTEM

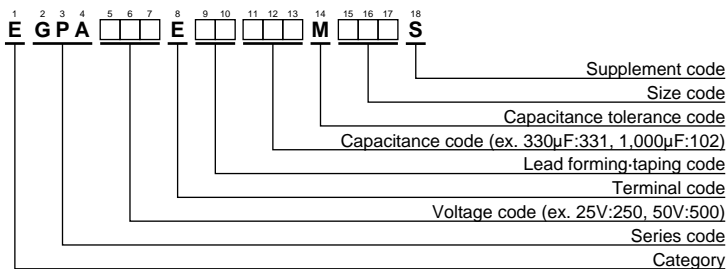

Please refer to "A guide to global code (radial lead type)"

◆STANDARD RATINGS

WV (Vdc)	Cap (µF)	Case size φD×L(mm)	ESR (Ωmax/100kHz)		Rated ripple current (mA <sub>rms</sub> /125°C, 100kHz)	Part No.	WV (Vdc)	Cap (µF)	Case size φD×L(mm)	ESR (Ωmax/100kHz)		Rated ripple current (mA <sub>rms</sub> /125°C, 100kHz)	Part No.
			20°C	-40°C						20°C	-40°C		
25	1,200	12.5×20	0.044	0.22	1,820	EGPA250E□□122MK20S	50	470	12.5×20	0.065	0.33	1,500	EGPA500E□□471MK20S
	1,500	14.5×20	0.037	0.19	2,100	EGPA250E□□152MU20S		560	14.5×20	0.055	0.28	1,740	EGPA500E□□561MU20S
	1,800	12.5×25	0.033	0.17	2,280	EGPA250E□□182MK25S		680	12.5×25	0.048	0.24	1,900	EGPA500E□□681MK25S
	1,800	16×20	0.034	0.17	2,280	EGPA250E□□182ML20S		680	16×20	0.043	0.22	2,040	EGPA500E□□681ML20S
	2,200	12.5×30	0.029	0.13	2,560	EGPA250E□□222MK30S		820	12.5×30	0.041	0.18	2,150	EGPA500E□□821MK30S
	2,200	14.5×25	0.028	0.14	2,620	EGPA250E□□222MU25S		820	14.5×25	0.040	0.20	2,190	EGPA500E□□821MU25S
	2,700	12.5×35	0.024	0.11	2,970	EGPA250E□□332MK35S		1,000	12.5×35	0.034	0.15	2,510	EGPA500E□□102MK35S
	2,700	14.5×30	0.023	0.10	3,060	EGPA250E□□272MU30S		1,000	14.5×30	0.036	0.16	2,470	EGPA500E□□102MU30S
	2,700	16×25	0.026	0.13	2,860	EGPA250E□□272ML25S		1,000	16×25	0.031	0.16	2,620	EGPA500E□□102ML25S
	2,700	18×20	0.032	0.16	2,490	EGPA250E□□272MM20S		1,000	18×20	0.039	0.20	2,240	EGPA500E□□102MM20S
	3,300	12.5×40	0.021	0.095	3,340	EGPA250E□□332MK40S		1,200	12.5×40	0.028	0.13	2,870	EGPA500E□□122MK40S
	3,300	14.5×35	0.021	0.095	3,380	EGPA250E□□332MU35S		1,200	14.5×35	0.029	0.13	2,840	EGPA500E□□122MU35S
	3,300	16×30	0.023	0.100	3,160	EGPA250E□□332ML30S		1,200	16×30	0.027	0.13	2,940	EGPA500E□□122ML30S
	3,900	16×35	0.020	0.090	3,590	EGPA250E□□392ML35S		1,200	18×25	0.029	0.15	2,750	EGPA500E□□122MM25S
	3,900	18×25	0.024	0.120	3,010	EGPA250E□□392MM25S		1,500	16×35	0.023	0.10	3,300	EGPA500E□□152ML35S
	4,700	14.5×40	0.018	0.081	3,730	EGPA250E□□472MU40S		1,800	14.5×40	0.024	0.11	3,230	EGPA500E□□182MU40S
	4,700	18×30	0.022	0.099	3,390	EGPA250E□□472MM30S		1,800	18×30	0.026	0.12	3,140	EGPA500E□□182MM30S
	5,600	16×40	0.017	0.077	3,970	EGPA250E□□562ML40S		2,200	16×40	0.020	0.090	3,720	EGPA500E□□222ML40S
	5,600	18×35	0.019	0.086	3,840	EGPA250E□□562MM35S		2,200	18×35	0.022	0.100	3,510	EGPA500E□□222MM35S
	6,800	18×40	0.016	0.072	4,230	EGPA250E□□682MM40S		2,700	18×40	0.018	0.080	3,940	EGPA500E□□272MM40S
35	680	12.5×20	0.044	0.22	1,820	EGPA350E□□681MK20S	63	330	12.5×20	0.130	0.78	1,090	EGPA630E□□331MK20S
	1,000	12.5×25	0.033	0.17	2,280	EGPA350E□□102MK25S		470	12.5×25	0.089	0.54	1,390	EGPA630E□□471MK25S
	1,000	14.5×20	0.037	0.19	2,100	EGPA350E□□102MU20S		470	14.5×20	0.104	0.63	1,270	EGPA630E□□471MU20S
	1,200	12.5×30	0.029	0.13	2,560	EGPA350E□□122MK30S		560	12.5×30	0.076	0.42	1,600	EGPA630E□□561MK30S
	1,200	16×20	0.034	0.17	2,280	EGPA350E□□122ML20S		560	14.5×25	0.076	0.46	1,600	EGPA630E□□561MU25S
	1,200	14.5×25	0.028	0.14	2,620	EGPA350E□□122MU25S		560	16×20	0.070	0.42	1,600	EGPA630E□□561ML20S
	1,500	12.5×35	0.024	0.11	2,970	EGPA350E□□152MK35S		680	12.5×35	0.063	0.35	1,860	EGPA630E□□681MK35S
	1,500	14.5×30	0.023	0.10	3,060	EGPA350E□□152MU30S		680	14.5×30	0.064	0.36	1,840	EGPA630E□□681MU30S
	1,500	18×20	0.032	0.16	2,490	EGPA350E□□152MM20S		680	16×25	0.051	0.31	2,030	EGPA630E□□681ML25S
	1,800	12.5×40	0.021	0.095	3,340	EGPA350E□□182MK40S		680	18×20	0.067	0.41	1,720	EGPA630E□□681MM20S
	1,800	16×25	0.026	0.130	2,860	EGPA350E□□182ML25S		820	12.5×40	0.050	0.28	2,160	EGPA630E□□821MK40S
	2,200	14.5×35	0.021	0.095	3,380	EGPA350E□□222MU35S		820	14.5×35	0.054	0.30	2,100	EGPA630E□□821MU35S
	2,200	16×30	0.023	0.100	3,160	EGPA350E□□222ML30S		820	16×30	0.045	0.25	2,290	EGPA630E□□821ML30S
	2,200	18×25	0.024	0.120	3,010	EGPA350E□□222MM25S		1,000	16×35	0.037	0.21	2,630	EGPA630E□□102ML35S
	2,700	14.5×40	0.018	0.081	3,730	EGPA350E□□272MU40S		1,000	18×25	0.050	0.30	2,110	EGPA630E□□102MM25S
	2,700	16×35	0.020	0.090	3,590	EGPA350E□□272ML35S		1,200	14.5×40	0.042	0.24	2,470	EGPA630E□□122MU40S
	2,700	18×30	0.022	0.099	3,390	EGPA350E□□272MM30S		1,200	18×30	0.044	0.25	2,420	EGPA630E□□122MM30S
	3,300	16×40	0.017	0.077	3,970	EGPA350E□□332ML40S		1,500	16×40	0.030	0.17	3,000	EGPA630E□□152ML40S
	3,300	18×35	0.019	0.086	3,840	EGPA350E□□332MM35S		1,500	18×35	0.036	0.20	2,770	EGPA630E□□152MM35S
	4,700	18×40	0.016	0.072	4,230	EGPA350E□□472MM40S		1,800	18×40	0.029	0.16	3,150	EGPA630E□□182MM40S

□□ : Lead forming / Taping code

◆RATED RIPPLE CURRENT MULTIPLIERS

●Frequency Multipliers

Capacitance(µF)	Frequency(Hz)			
	120	1k	10k	100k
330 to 560	0.50	0.85	0.94	1.00
680 to 1,800	0.60	0.87	0.95	1.00
2,200 to 3,900	0.75	0.90	0.95	1.00
4,700 to 6,800	0.85	0.95	0.98	1.00

The endurance of capacitors is shorted with internal heating produced by ripple current at the rate of halving the lifetime with every 5°C rise. When long life performance is required in actual use, the rms ripple current has to be reduced.

# GXE Series

- For automobile modules and other high temperature applications
- Downsize, long life, low impedance and better low temperature characteristics
- Endurance with ripple current : 2,000 to 5,000 hours at 125°C
- Solvent-proof type except 63 to 450V (see PRECAUTIONS AND GUIDELINES)
- RoHS Compliant

GXE → Longer life → GXL



## ◆ SPECIFICATIONS

Items	Characteristics										
Category	-40 to +125°C (10 to 250V <sub>dc</sub> ) -25 to +125°C (350 to 450V <sub>dc</sub> )										
Temperature Range											
Rated Voltage Range	10 to 450V <sub>dc</sub>										
Capacitance Tolerance	±20% (M) (at 20°C, 120Hz)										
Leakage Current	10 to 100V <sub>dc</sub>					160 to 450V <sub>dc</sub>					
	I=0.03CV or 4µA, whichever is greater.										
	CV≤1,000 I=0.1CV+40					CV>1,000 I=0.04CV+100					
Where, I : Max. leakage current (µA), C : Nominal capacitance (µF), V : Rated voltage (V) (at 20°C, 1 minute)											
Dissipation Factor (tanδ)	Rated voltage (V <sub>dc</sub> )	10V	16V	25V	35V	50V	63V	80V	100V	160 to 250V	350 to 450V
	tanδ (Max.)	0.20	0.16	0.14	0.12	0.10	0.10	0.08	0.08	0.20	0.24
When nominal capacitance exceeds 1,000µF, add 0.02 to the above value for each 1,000µF increase. (at 20°C, 120Hz)											
Low Temperature Characteristics (Max. Impedance Ratio)	Rated voltage (V <sub>dc</sub> )	10V	16V	25V	35V	50V	63V	80V	100V	160 to 250V	350 to 450V
	Z(-25°C)/Z(+20°C)	3	2	2	2	2	2	2	2	3	6
	Z(-40°C)/Z(+20°C)	6	4	4	4	4	4	4	4	6	—
(at 120Hz)											
Endurance	The following specifications shall be satisfied when the capacitors are restored to 20°C after subjected to DC voltage with the rated ripple current is applied for the specified time at 125°C.										
		10 to 100V <sub>dc</sub>					160 to 450V <sub>dc</sub>				
	Time	φ8 : 2,000hours φ10 : 3,000hours φ12.5 & φ16 : 5,000hours					2,000hours				
	Capacitance change	≤±30% of the initial value					≤±20% of the initial value				
	D.F. (tanδ)	≤300% of the initial specified value					≤200% of the initial specified value				
Leakage current	≤The initial specified value					≤The initial specified value					
Shelf Life	The following specifications shall be satisfied when the capacitors are restored to 20°C after exposing them for 1,000 hours (500 hours for 350 to 450VV) at 125°C without voltage applied.										
		10 to 100V <sub>dc</sub>					160 to 450V <sub>dc</sub>				
	Capacitance change	≤±30% of the initial value					≤±20% of the initial value				
	D.F. (tanδ)	≤300% of the initial specified value					≤200% of the initial specified value				
	Leakage current	≤The initial specified value					≤500% of the initial specified value				

## ◆ DIMENSIONS [mm]

- Terminal Code : E

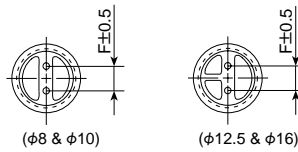
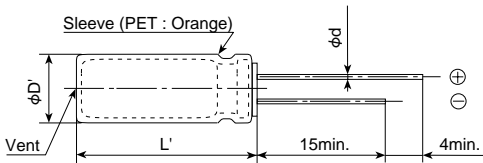

φD	8	10	12.5	16
φd	0.6	0.6	0.6	0.8
F	3.5	5.0	5.0	7.5
φD'	φD+0.5max.			
L'	L+2.0max.			

## ◆ PART NUMBERING SYSTEM

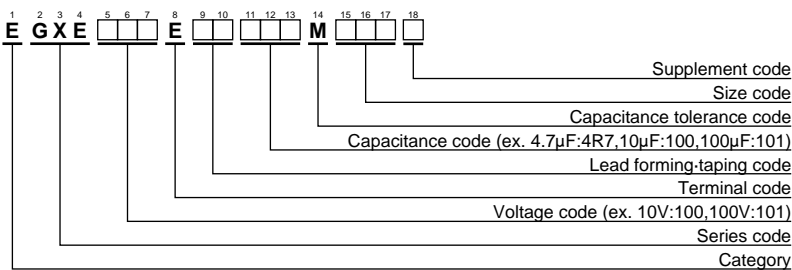

Please refer to "A guide to global code (radial lead type)"



◆STANDARD RATINGS

□ is non solvent-proof.

WV (Vdc)	Cap (µF)	Case size φD×L(mm)	Impedance (Ωmax/20°C, 100kHz)	Rated ripple current (mA <sub>rms</sub> /125°C, Note1)	Part No.	WV (Vdc)	Cap (µF)	Case size φD×L(mm)	Impedance (Ωmax/20°C, 100kHz)	Rated ripple current (mA <sub>rms</sub> /125°C, Note1)	Part No.	
10	220	8×12	0.32	340	EGXE100E□□221MH12D	80	47	10×12.5	0.80	480	EGXE800E□□470MJC5S	
	330	10×12.5	0.15	620	EGXE100E□□331MJC5S		100	10×20	0.39	790	EGXE800E□□101MJ20S	
	470	10×12.5	0.15	620	EGXE100E□□471MJC5S		220	12.5×25	0.18	1,240	EGXE800E□□221MK25S	
	1,000	10×20	0.075	950	EGXE100E□□102MJ20S		330	12.5×30	0.16	1,390	EGXE800E□□331MK30S	
	2,200	12.5×25	0.040	1,350	EGXE100E□□222MK25S		470	16×25	0.11	1,500	EGXE800E□□471ML25S	
	3,300	16×25	0.031	1,620	EGXE100E□□332ML25S		100	4.7	8×12	2.0	130	EGXE101E□□4R7MH12D
	4,700	16×31.5	0.025	1,860	EGXE100E□□472MLN3S			10	8×12	1.5	150	EGXE101E□□100MH12D
16	100	8×12	0.32	340	EGXE160E□□101MH12D	22		10×12.5	0.80	480	EGXE101E□□220MJC5S	
	220	10×12.5	0.15	620	EGXE160E□□221MJC5S	33		10×12.5	0.80	480	EGXE101E□□330MJC5S	
	330	10×12.5	0.15	620	EGXE160E□□331MJC5S	47		10×16	0.55	630	EGXE101E□□470MJ16S	
	470	10×16	0.094	790	EGXE160E□□471MJ16S	100		12.5×20	0.25	990	EGXE101E□□101MK20S	
	1,000	12.5×20	0.058	1,080	EGXE160E□□102MK20S	220		16×25	0.11	1,500	EGXE101E□□221ML25S	
	2,200	16×25	0.031	1,620	EGXE160E□□222ML25S	330	16×31.5	0.079	1,790	EGXE101E□□331MLN3S		
	3,300	16×31.5	0.025	1,860	EGXE160E□□332MLN3S	160	22	10×20	—	115	EGXE161E□□220MJ20S	
25	100	8×12	0.32	340	EGXE250E□□101MH12D		33	10×25	—	154	EGXE161E□□330MJ25S	
	220	10×12.5	0.15	620	EGXE250E□□221MJC5S		47	12.5×20	—	187	EGXE161E□□470MK20S	
	330	10×16	0.094	790	EGXE250E□□331MJ16S		68	12.5×25	—	245	EGXE161E□□680MK25S	
	470	10×20	0.075	950	EGXE250E□□471MJ20S		100	16×25	—	329	EGXE161E□□101ML25S	
	1,000	12.5×25	0.040	1,350	EGXE250E□□102MK25S		150	16×31.5	—	434	EGXE161E□□151MLN3S	
	2,200	16×31.5	0.025	1,860	EGXE250E□□222MLN3S		200	10	10×20	—	78	EGXE201E□□100MJ20S
	35	100	8×12	0.32	340	EGXE350E□□101MH12D		22	10×25	—	126	EGXE201E□□220MJ25S
100		10×12.5	0.15	620	EGXE350E□□101MJC5S	33		12.5×20	—	157	EGXE201E□□330MK20S	
220		10×16	0.094	790	EGXE350E□□221MJ16S	47		12.5×25	—	204	EGXE201E□□470MK25S	
330		10×20	0.075	950	EGXE350E□□331MJ20S	68		16×20	—	250	EGXE201E□□680ML20S	
470		12.5×20	0.058	1,080	EGXE350E□□471MK20S	100		16×25	—	329	EGXE201E□□101ML25S	
1,000		16×25	0.031	1,620	EGXE350E□□102ML25S	250		10	10×20	—	78	EGXE251E□□100MJ20S
50		10	8×12	0.75	180		EGXE500E□□100MH12D	22	12.5×20	—	128	EGXE251E□□220MK20S
	22	8×12	0.50	250	EGXE500E□□220MH12D		33	12.5×25	—	171	EGXE251E□□330MK25S	
	33	8×12	0.50	280	EGXE500E□□330MH12D		47	16×25	—	225	EGXE251E□□470ML25S	
	47	8×12	0.50	280	EGXE500E□□470MH12D		68	16×31.5	—	292	EGXE251E□□680MLN3S	
	100	10×12.5	0.20	520	EGXE500E□□101MJC5S		350	4.7	10×20	—	53	EGXE351E□□4R7MJ20S
	220	10×20	0.098	880	EGXE500E□□221MJ20S			10	10×25	—	85	EGXE351E□□100MJ25S
	330	12.5×20	0.081	990	EGXE500E□□331MK20S	22		12.5×25	—	139	EGXE351E□□220MK25S	
470	12.5×25	0.059	1,150	EGXE500E□□471MK25S	33	16×25		—	189	EGXE351E□□330ML25S		
1,000	16×31.5	0.032	1,590	EGXE500E□□102MLN3S	47	16×31.5		—	243	EGXE351E□□470MLN3S		
63	33	8×12	1.5	150	EGXE630E□□330MH12D	400		4.7	10×20	—	53	EGXE401E□□4R7MJ20S
	47	10×12.5	0.59	530	EGXE630E□□470MJC5S			10	10×25	—	86	EGXE401E□□100MJ25S
	100	10×16	0.41	690	EGXE630E□□101MJ16S		22	12.5×30	—	142	EGXE401E□□220MK30S	
	220	12.5×20	0.16	1,050	EGXE630E□□221MK20S		33	16×25	—	189	EGXE401E□□330ML25S	
	330	12.5×25	0.12	1,290	EGXE630E□□331MK25S		47	16×31.5	—	243	EGXE401E□□470MLN3S	
	470	12.5×30	0.097	1,460	EGXE630E□□471MK30S		450	4.7	10×25	—	58	EGXE451E□□4R7MJ25S
	1,000	16×31.5	0.059	1,850	EGXE630E□□102MLN3S			10	12.5×20	—	86	EGXE451E□□100MK20S
80	22	8×12	1.5	150	EGXE800E□□220MH12D	22		16×25	—	154	EGXE451E□□220ML25S	
	33	10×12.5	0.8	480	EGXE800E□□330MJC5S	33		16×31.5	—	203	EGXE451E□□330MLN3S	

□□ : Lead forming / Taping code  
 (Note1) Ripple current frequency  
 10 to 100V = 100kHz  
 160 to 450V = 120Hz

◆RATED RIPPLE CURRENT MULTIPLIERS

●(10 to 100Vdc) Frequency Multipliers

Capacitance (µF)	Frequency (Hz)			
	120	1k	10k	100k
4.7 to 100	0.40	0.75	0.90	1.00
220 to 470	0.50	0.85	0.94	1.00
1,000	0.60	0.87	0.95	1.00
2,200 to 3,300	0.75	0.90	0.95	1.00
4,700	0.85	0.95	0.98	1.00

●(160 to 450Vdc) Frequency Multipliers

Capacitance (µF)	Frequency (Hz)						
	50	120	300	1k	10k	100k	
4.7 to 33	0.75	1.00	1.25	1.50	1.75	1.80	
47 to 150	0.80	1.00	1.15	1.30	1.40	1.50	

The endurance of capacitors is shorted with internal heating produced by ripple current at the rate of halving the lifetime with every 5°C rise. When long life performance is required in actual use, the rms ripple current has to be reduced.

# GXL Series

- Long-Life version of GXE series
- For automobile modules and other high temperature applications
- Endurance with ripple current : 5,000 to 10,000 hours at 125°C
- Solvent-proof type (see PRECAUTIONS AND GUIDELINES)
- RoHS Compliant



## ◆ SPECIFICATIONS

Items	Characteristics					
Category	-40 to +125°C					
Temperature Range	-40 to +125°C					
Rated Voltage Range	10 to 50V <sub>dc</sub>					
Capacitance Tolerance	±20% (M) (at 20°C, 120Hz)					
Leakage Current	I=0.03CV or 4μA, whichever is greater. Where, I : Max. leakage current (μA), C : Nominal capacitance (μF), V : Rated voltage (V) (at 20°C, 1 minute)					
Dissipation Factor (tanδ)	Rated voltage (V <sub>dc</sub> )	10V	16V	25V	35V	50V
	tanδ (Max.)	0.20	0.16	0.14	0.12	0.10
	When nominal capacitance exceeds 1,000μF, add 0.02 to the above value for each 1,000μF increase. (at 20°C, 120Hz)					
Low Temperature Characteristics (Max. Impedance Ratio)	Rated voltage (V <sub>dc</sub> )	10V	16V	25V	35V	50V
	Z(-25°C)/Z(+20°C)	3	2	2	2	2
	Z(-40°C)/Z(+20°C)	6	4	4	4	4
(at 120Hz)						
Endurance	The following specifications shall be satisfied when the capacitors are restored to 20°C after subjected to DC voltage with the rated ripple current is applied for 10,000 hours (5,000 hours for φ10) at 125°C.					
	Capacitance change	≤±30% of the initial value				
	D.F. (tanδ)	≤±300% of the initial specified value				
	Leakage current	≤The initial specified value				
Shelf Life	The following specifications shall be satisfied when the capacitors are restored to 20°C after exposing them for 1,000 hours at 125°C without voltage applied.					
	Capacitance change	≤±30% of the initial value				
	D.F. (tanδ)	≤±300% of the initial specified value				
	Leakage current	≤The initial specified value				

## ◆ DIMENSIONS [mm]

- Terminal Code : E

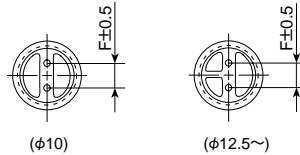
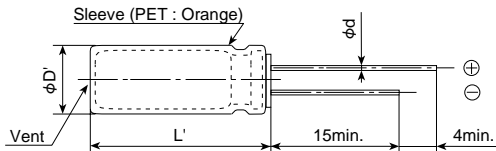

φD	10	12.5	16
φd	0.6	0.6	0.8
F	5.0	5.0	7.5
φD'	φD+0.5max.		
L'	L+1.5max.		

Gas escape end seal

## ◆ PART NUMBERING SYSTEM

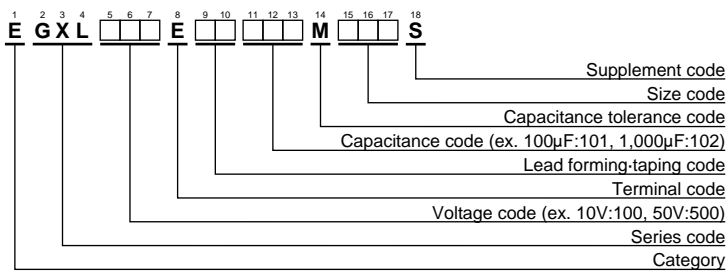

Please refer to "A guide to global code (radial lead type)"

**◆STANDARD RATINGS**

WV (Vdc)	Cap (μF)	Case size φD×L(mm)	Impedance (Ωmax/20°C, 100kHz)	Rated ripple current (mA <sub>rms</sub> /125°C, 100kHz)	Part No.
10	330	10 × 12.5	0.17	800	EGXL100E□□331MJC5S
	470	10 × 12.5	0.17	800	EGXL100E□□471MJC5S
	1,000	10 × 20	0.094	1,300	EGXL100E□□102MJ20S
	2,200	12.5 × 25	0.055	2,050	EGXL100E□□222MK25S
	3,300	16 × 25	0.035	2,500	EGXL100E□□332ML25S
	4,700	16 × 31.5	0.027	3,000	EGXL100E□□472MLN3S
16	220	10 × 12.5	0.17	800	EGXL160E□□221MJC5S
	330	10 × 12.5	0.17	800	EGXL160E□□331MJC5S
	470	10 × 16	0.12	1,050	EGXL160E□□471MJ16S
	1,000	12.5 × 20	0.067	1,650	EGXL160E□□102MK20S
	2,200	16 × 25	0.035	2,500	EGXL160E□□222ML25S
	3,300	16 × 31.5	0.027	3,000	EGXL160E□□332MLN3S
25	220	10 × 12.5	0.17	800	EGXL250E□□221MJC5S
	330	10 × 16	0.12	1,050	EGXL250E□□331MJ16S
	470	10 × 20	0.094	1,300	EGXL250E□□471MJ20S
	1,000	12.5 × 25	0.055	2,050	EGXL250E□□102MK25S
	2,200	16 × 31.5	0.027	3,000	EGXL250E□□222MLN3S
	3,300	16 × 31.5	0.027	3,000	EGXL250E□□332MLN3S
35	100	10 × 12.5	0.17	800	EGXL350E□□101MJC5S
	220	10 × 16	0.12	1,050	EGXL350E□□221MJ16S
	330	10 × 20	0.094	1,300	EGXL350E□□331MJ20S
	470	12.5 × 20	0.067	1,650	EGXL350E□□471MK20S
	1,000	16 × 25	0.035	2,500	EGXL350E□□102ML25S
	1,000	16 × 25	0.035	2,500	EGXL350E□□102ML25S
50	100	10 × 12.5	0.30	590	EGXL500E□□101MJC5S
	220	10 × 20	0.19	970	EGXL500E□□221MJ20S
	330	12.5 × 20	0.11	1,380	EGXL500E□□331MK20S
	470	12.5 × 25	0.085	1,700	EGXL500E□□471MK25S
	1,000	16 × 31.5	0.043	2,490	EGXL500E□□102MLN3S
	1,000	16 × 31.5	0.043	2,490	EGXL500E□□102MLN3S

□□ : Lead forming / Taping code

**◆RATED RIPPLE CURRENT MULTIPLIERS**

## ●Frequency Multipliers

Capacitance(μF) \ Frequency(Hz)	120	1k	10k	100k
100	0.40	0.75	0.90	1.00
220 to 470	0.50	0.85	0.94	1.00
1,000	0.60	0.87	0.95	1.00
2,200 to 3,300	0.75	0.90	0.95	1.00
4,700	0.85	0.95	0.98	1.00

The endurance of capacitors is shorted with internal heating produced by ripple current at the rate of halving the lifetime with every 5°C rise. When long life performance is required in actual use, the rms ripple current has to be reduced.

Upgrade!

# LBG Series

- For airbag application
- High capacitance, low impedance, and good low temperature behavior
- Endurance with ripple current : 5,000 hours at 105°C
- Solvent-proof type (see PRECAUTIONS AND GUIDELINES)
- RoHS Compliant



## ◆ SPECIFICATIONS

Items	Characteristics		
Category			
Temperature Range	-55 to +105°C		
Rated Voltage Range	25 & 35V <sub>dc</sub>		
Capacitance Range	1,000 to 11,000µF (at 20°C, 120Hz)		
Capacitance Tolerance	0 to +30% (A) (at 20°C, 120Hz)		
Leakage Current	I=0.01CV Where, I : Max. leakage current (µA), C : Nominal capacitance (µF), V : Rated voltage (V) (at 20°C after 2 minutes)		
Dissipation Factor (tanδ)	Rated voltage (V <sub>dc</sub> )	25V	35V
	tanδ (Max.)	0.20	0.16
	When nominal capacitance exceeds 1,000µF, add 0.02 to the value above for each 1,000µF increase. (at 20°C, 120Hz)		
Low Temperature Characteristics (Max. Impedance Ratio)	Rated voltage (V <sub>dc</sub> )	25V	35V
	Z(-55°C)/Z(+20°C)	3	3
	Impedance at -40°C and 20°C 100kHz in the STANDARD RATINGS (at 120Hz)		
Endurance	The following specifications shall be satisfied when the capacitors are restored to 20°C after subjected to DC voltage with the rated ripple current is applied for 5,000 hours at 105°C.		
	Capacitance change	≤±20% of the initial value	
	D.F. (tanδ)	≤200% of the initial specified value	
	Leakage current	≤The initial specified value	
Shelf Life	The following specifications shall be satisfied when the capacitors are restored to 20°C after exposing them for 1,000 hours at 105°C without voltage applied.		
	Capacitance change	≤±20% of the initial value	
	D.F. (tanδ)	≤200% of the initial specified value	
	Leakage current	≤The initial specified value	

## ◆ DIMENSIONS [mm]

### ● Terminal Code : E

Sleeve (PET : Dark blue)

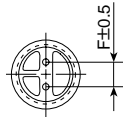
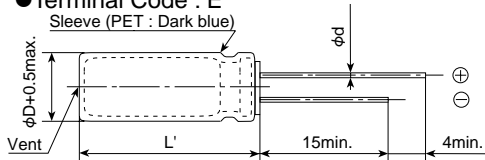

Gas escape end seal

φD	12.5	14.5	16	18
φd	0.6	0.6	0.8	0.8
F	5.0	5.0	7.5	7.5
L'	L+1.5max.			

## ◆ PART NUMBERING SYSTEM

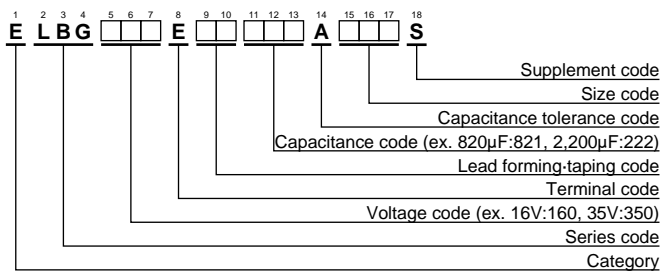

Please refer to "A guide to global code (radial lead type)"

**◆STANDARD RATINGS**

WV (Vdc)	Cap (μF)	Case size φD×L(mm)	Impedance (Ωmax/100kHz)		Rated ripple current (mA <sub>rms</sub> /105°C,100kHz)	Part No.
			20°C	-40°C		
25	1,700	12.5 × 20	0.057	0.29	1,700	ELBG250E□□172AK20S
	2,400	12.5 × 25	0.045	0.23	2,000	ELBG250E□□242AK25S
	2,400	14.5 × 20	0.051	0.26	2,000	ELBG250E□□242AU20S
	2,800	12.5 × 30	0.039	0.20	2,300	ELBG250E□□282AK30S
	3,000	16 × 20	0.044	0.22	2,250	ELBG250E□□302AL20S
	3,400	14.5 × 25	0.041	0.21	2,400	ELBG250E□□342AU25S
	3,500	12.5 × 35	0.033	0.17	2,700	ELBG250E□□352AK35S
	4,200	16 × 25	0.033	0.17	2,600	ELBG250E□□422AL25S
	4,200	18 × 20	0.042	0.21	2,500	ELBG250E□□422AM20S
	4,500	12.5 × 40	0.027	0.14	3,100	ELBG250E□□452AK40S
	4,600	14.5 × 31.5	0.032	0.16	2,700	ELBG250E□□462AUN3S
	5,400	14.5 × 35.5	0.028	0.14	3,100	ELBG250E□□542AUP1S
	5,600	16 × 31.5	0.026	0.13	3,200	ELBG250E□□562ALN3S
	6,000	18 × 25	0.030	0.15	2,800	ELBG250E□□602AM25S
	6,400	14.5 × 40	0.025	0.13	3,400	ELBG250E□□642AU40S
	6,600	16 × 35.5	0.023	0.12	3,500	ELBG250E□□662ALP1S
	7,800	16 × 40	0.021	0.11	3,800	ELBG250E□□782AL40S
7,900	18 × 31.5	0.024	0.12	3,500	ELBG250E□□792AMN3S	
9,200	18 × 35.5	0.022	0.11	3,700	ELBG250E□□922AMP1S	
11,000	18 × 40	0.020	0.10	4,000	ELBG250E□□113AM40S	
35	1,000	12.5 × 20	0.057	0.29	1,700	ELBG350E□□102AK20S
	1,400	12.5 × 25	0.045	0.23	2,000	ELBG350E□□142AK25S
	1,400	14.5 × 20	0.051	0.26	2,000	ELBG350E□□142AU20S
	1,600	12.5 × 30	0.039	0.20	2,300	ELBG350E□□162AK30S
	1,800	16 × 20	0.044	0.22	2,250	ELBG350E□□182AL20S
	2,000	14.5 × 25	0.041	0.21	2,400	ELBG350E□□202AU25S
	2,100	12.5 × 35	0.033	0.17	2,700	ELBG350E□□212AK35S
	2,500	16 × 25	0.033	0.17	2,600	ELBG350E□□252AL25S
	2,500	18 × 20	0.042	0.21	2,500	ELBG350E□□252AM20S
	2,700	12.5 × 40	0.027	0.14	3,100	ELBG350E□□272AK40S
	2,800	14.5 × 31.5	0.032	0.16	2,700	ELBG350E□□282AUN3S
	3,200	14.5 × 35.5	0.028	0.14	3,100	ELBG350E□□322AUP1S
	3,400	16 × 31.5	0.026	0.13	3,200	ELBG350E□□342ALN3S
	3,600	18 × 25	0.030	0.15	2,800	ELBG350E□□362AM25S
	3,800	14.5 × 40	0.025	0.13	3,400	ELBG350E□□382AU40S
	4,000	16 × 35.5	0.023	0.12	3,500	ELBG350E□□402ALP1S
	4,700	16 × 40	0.021	0.11	3,800	ELBG350E□□472AL40S
4,800	18 × 31.5	0.024	0.12	3,500	ELBG350E□□482AMN3S	
5,600	18 × 35.5	0.022	0.11	3,700	ELBG350E□□562AMP1S	
6,700	18 × 40	0.020	0.10	4,000	ELBG350E□□672AM40S	

□□ : Lead forming / Taping code

**◆RATED RIPPLE CURRENT MULTIPLIERS**

## ●Frequency Multipliers

Capacitance (μF)	Frequency (Hz)			
	120	1k	10k	100k
1,000 to 2,000	0.60	0.87	0.95	1.00
2,100 to 3,800	0.75	0.90	0.95	1.00
4,000 to 11,000	0.85	0.95	0.98	1.00

The endurance of capacitors is shorted with internal heating produced by ripple current at the rate of halving the lifetime with every 5°C rise. When long life performance is required in actual use, the rms ripple current has to be reduced.



New!

# KZJ Series

- Super low ESR/impedance capacitors due to very low resistivity electrolyte
- Rated voltage range : 6.3 to 16V, Nominal capacitance range : 470 to 3,300 $\mu$ F
- Endurance with ripple current : 2,000 hours at 105°C
- The KZJ series capacitors are designed for computer motherboards
- Non solvent-proof
- RoHS Compliant

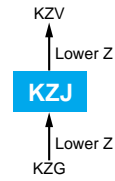

## ◆ SPECIFICATIONS

Items	Characteristics			
Category	-40 to +105°C			
Temperature Range	-40 to +105°C			
Rated Voltage Range	6.3 to 16V <sub>dc</sub>			
Capacitance Tolerance	±20% (M) (at 20°C, 120Hz)			
Leakage Current	I=0.01CV or 3 $\mu$ A, whichever is greater. Where, I : Max. leakage current ( $\mu$ A), C : Nominal capacitance ( $\mu$ F), V : Rated voltage (V <sub>dc</sub> ) (at 20°C after 2 minutes)			
Dissipation Factor (tan $\delta$ )	Rated voltage (V <sub>dc</sub> )	6.3V	10V	16V
	tan $\delta$ (Max.)	0.22	0.19	0.16
	When nominal capacitance exceeds 1,000 $\mu$ F, add 0.02 to the value above for each 1,000 $\mu$ F increase. (at 20°C, 120Hz)			
Low Temperature Characteristics (Max. Impedance Ratio)	Rated voltage (V <sub>dc</sub> )	6.3V	10V	16V
	Z (-25°C) / Z (+20°C)	2	2	2
	Z (-40°C) / Z (+20°C)	3	3	3
(at 120Hz)				
Endurance	The following specifications shall be satisfied when the capacitors are restored to 20°C after subjected to DC voltage with the rated ripple current for 2,000 hours at 105°C.			
	Capacitance change	≤±25% of the initial measured value		
	D.F. (tan $\delta$ )	≤200% of the initial specified value		
	Leakage current	≤The initial specified value		
Shelf Life	The following specifications shall be satisfied when the capacitors are restored to 20°C after exposing them for 500 hours at 105°C without voltage applied.			
	Capacitance change	≤±25% of the initial measured value		
	D.F. (tan $\delta$ )	≤200% of the initial specified value		
	Leakage current	≤The initial specified value		

## ◆ DIMENSIONS [mm]

- Terminal Code : E

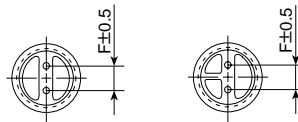
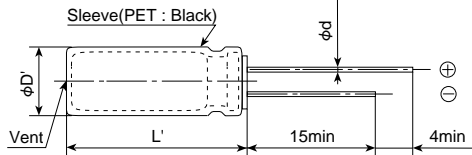

Gas escaped end seal

$\phi$ D	8	10	12.5
$\phi$ d	0.6	0.6	0.6
F	3.5	5.0	5.0
$\phi$ D'	$\phi$ D+0.5max.		
L'	L+1.5max.		

## ◆ PART NUMBERING SYSTEM

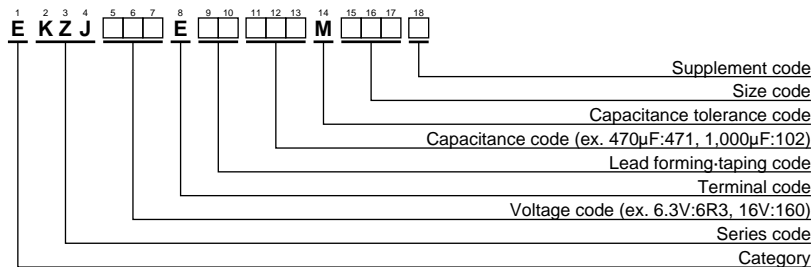

Please refer to "A guide to global code (radial lead type)"

**◆STANDARD RATINGS**

WV(Vdc)	Cap(μF)	Case size φD×L(mm)	Impedance (Ω <sub>max</sub> /20°C, 100kHz)	Rated ripple current (mA <sub>rms</sub> /105°C, 100kHz)	Part No.
6.3	1,000	8×11.5	0.021	1,310	EKZJ6R3E□□102MHB5D
	1,200	8×15	0.018	1,850	EKZJ6R3E□□122MH15D
	1,500	8×20	0.012	2,350	EKZJ6R3E□□152MH20D
	1,500	10×12.5	0.018	1,960	EKZJ6R3E□□152MJC5S
	1,800	8×20	0.012	2,350	EKZJ6R3E□□182MH20D
	1,800	10×16	0.0125	2,460	EKZJ6R3E□□182MJ16S
	2,200	8×20	0.012	2,350	EKZJ6R3E□□222MH20D
	2,200	8×25	0.011	2,710	EKZJ6R3E□□222MH25D
	2,200	10×16	0.0125	2,460	EKZJ6R3E□□222MJ16S
	2,200	10×20	0.011	2,920	EKZJ6R3E□□222MJ20S
	2,700	10×20	0.011	2,920	EKZJ6R3E□□272MJ20S
3,300	10×25	0.009	3,230	EKZJ6R3E□□332MJ25S	
10	680	8×11.5	0.021	1,310	EKZJ100E□□681MHB5D
	1,000	8×15	0.018	1,850	EKZJ100E□□102MH15D
	1,000	10×12.5	0.018	1,960	EKZJ100E□□102MJC5S
	1,500	8×20	0.012	2,350	EKZJ100E□□152MH20D
	1,500	8×25	0.011	2,710	EKZJ100E□□152MH25D
	1,500	10×16	0.0125	2,460	EKZJ100E□□152MJ16S
	1,800	10×20	0.011	2,920	EKZJ100E□□182MJ20S
	2,200	10×25	0.009	3,230	EKZJ100E□□222MJ25S
16	470	8×11.5	0.021	1,310	EKZJ160E□□471MHB5D
	680	8×15	0.018	1,850	EKZJ160E□□681MH15D
	680	10×12.5	0.018	1,960	EKZJ160E□□681MJC5S
	1,000	8×20	0.012	2,350	EKZJ160E□□102MH20D
	1,000	8×25	0.011	2,710	EKZJ160E□□102MH25D
	1,000	10×16	0.0125	2,460	EKZJ160E□□102MJ16S
	1,500	10×20	0.011	2,920	EKZJ160E□□152MJ20S
	1,800	10×25	0.009	3,230	EKZJ160E□□182MJ25S
	2,200	12.5×20	0.009	3,220	EKZJ160E□□222MK20S
	2,700	12.5×25	0.008	3,370	EKZJ160E□□272MK25S

□□ : Lead forming / Taping code

**◆RATED RIPPLE CURRENT MULTIPLIERS**

## ●Frequency Multipliers

Capacitance(μF)	Frequency (Hz)			
	120	1k	10k	100k
470	0.50	0.85	0.94	1.00
680 to 1,800	0.60	0.87	0.95	1.00
2,200 to 3,300	0.75	0.90	0.95	1.00

The endurance of capacitors is shorted with internal heating produced by ripple current at the rate of halving the lifetime with every 5°C rise. When long life performance is required in actual use, the rms ripple current has to be reduced.

# KZG Series

- Super low ESR/impedance capacitors due to very low resistivity electrolyte
- Rated voltage range : 6.3 to 16V, Nominal capacitance range : 470 to 3,300 $\mu$ F
- Endurance with ripple current : 2,000 hours at 105°C
- The KZG series capacitors are designed for computer motherboards
- Non solvent-proof
- RoHS Compliant

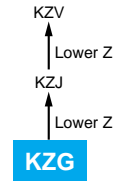

## ◆ SPECIFICATIONS

Items	Characteristics			
Category Temperature Range	-40 to +105°C			
Rated Voltage Range	6.3 to 16V <sub>dc</sub>			
Capacitance Tolerance	±20% (M) (at 20°C, 120Hz)			
Leakage Current	I=0.01CV or 3 $\mu$ A, whichever is greater. Where, I : Max. leakage current ( $\mu$ A), C : Nominal capacitance ( $\mu$ F), V : Rated voltage (V <sub>dc</sub> ) (at 20°C after 2 minutes)			
Dissipation Factor (tan $\delta$ )	Rated voltage (V <sub>dc</sub> )	6.3V	10V	16V
	tan $\delta$ (Max.)	0.22	0.19	0.16
	When nominal capacitance exceeds 1,000 $\mu$ F, add 0.02 to the value above for each 1,000 $\mu$ F increase. (at 20°C, 120Hz)			
Low Temperature Characteristics (Max. Impedance Ratio)	Rated voltage (V <sub>dc</sub> )	6.3V	10V	16V
	Z (-25°C) / Z (+20°C)	2	2	2
	Z (-40°C) / Z (+20°C)	3	3	3
	(at 120Hz)			
Endurance	The following specifications shall be satisfied when the capacitors are restored to 20°C after subjected to DC voltage with the rated ripple current for 2,000 hours at 105°C.			
	Capacitance change	≤±25% of the initial measured value		
	D.F. (tan $\delta$ )	≤200% of the initial specified value		
	Leakage current	≤The initial specified value		
Shelf Life	The following specifications shall be satisfied when the capacitors are restored to 20°C after exposing them for 1,000 hours at 105°C without voltage applied.			
	Capacitance change	≤±25% of the initial measured value		
	D.F. (tan $\delta$ )	≤200% of the initial specified value		
	Leakage current	≤The initial specified value		

## ◆ DIMENSIONS [mm]

- Terminal Code : E

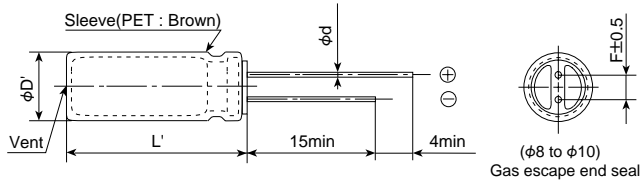

φD	8	10
φd	0.6	0.6
F	3.5	5.0
φD'	φD+0.5max.	
L'	L+1.5max.	

## ◆ PART NUMBERING SYSTEM

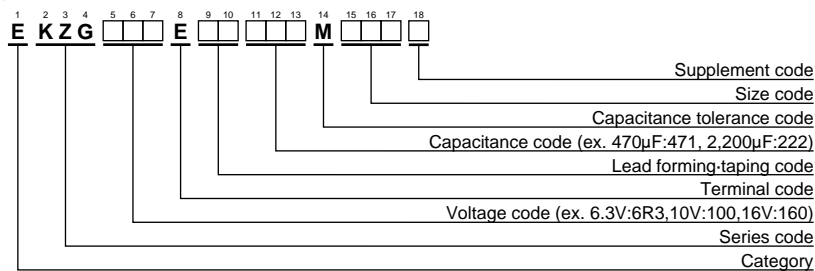

Please refer to "A guide to global code (radial lead type)"

**◆STANDARD RATINGS**

WV(Vdc)	Cap(μF)	Case size φD×L(mm)	Impedance (Ω <sub>max</sub> /20°C, 100kHz)	Rated ripple current (mA <sub>rms</sub> /105°C, 100kHz)	Part No.
6.3	820	8×11.5	0.036	1,140	EKZG6R3E□□821MHB5D
	1,200	8×15	0.028	1,490	EKZG6R3E□□122MH15D
	1,500	10×12.5	0.026	1,540	EKZG6R3E□□152MJC5S
	1,800	8×20	0.021	1,870	EKZG6R3E□□182MH20D
	1,800	10×16	0.019	2,000	EKZG6R3E□□182MJ16S
	2,200	10×20	0.013	2,550	EKZG6R3E□□222MJ20S
	3,300	10×25	0.012	2,800	EKZG6R3E□□332MJ25S
10	680	8×11.5	0.036	1,140	EKZG100E□□681MHB5D
	1,000	8×15	0.028	1,490	EKZG100E□□102MH15D
	1,000	10×12.5	0.026	1,540	EKZG100E□□102MJC5S
	1,500	8×20	0.021	1,870	EKZG100E□□152MH20D
	1,500	10×16	0.019	2,000	EKZG100E□□152MJ16S
	1,800	10×20	0.013	2,550	EKZG100E□□182MJ20S
	2,200	10×25	0.012	2,800	EKZG100E□□222MJ25S
16	470	8×11.5	0.036	1,140	EKZG160E□□471MHB5D
	680	8×15	0.028	1,490	EKZG160E□□681MH15D
	680	10×12.5	0.026	1,540	EKZG160E□□681MJC5S
	1,000	8×20	0.021	1,870	EKZG160E□□102MH20D
	1,000	10×16	0.019	2,000	EKZG160E□□102MJ16S
	1,500	10×20	0.013	2,550	EKZG160E□□152MJ20S
	1,800	10×25	0.012	2,800	EKZG160E□□182MJ25S

□□ : Lead forming / Taping code

**◆RATED RIPPLE CURRENT MULTIPLIERS**

## ●Frequency Multipliers

Capacitance(μF)	Frequency (Hz)			
	120	1k	10k	100k
470	0.50	0.85	0.94	1.00
680 to 1,800	0.60	0.87	0.95	1.00
2,200 to 3,300	0.75	0.90	0.95	1.00

The endurance of capacitors is shorted with internal heating produced by ripple current at the rate of halving the lifetime with every 5°C rise. When long life performance is required in actual use, the rms ripple current has to be reduced.

LLA Series

- Endurance : 1,000 hours at 85°C
- Solvent-proof (see PRECAUTIONS AND GUIDELINES)
- RoHS Compliant

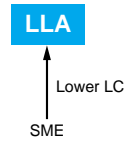

◆SPECIFICATIONS

Items	Characteristics
Category	
Temperature Range	-40 to +85°C
Rated Voltage Range	6.3 to 50V <sub>dc</sub>
Capacitance Tolerance	±20% (M) (at 20°C, 120Hz)
Leakage Current	I=0.002CV or 0.2μA, whichever is greater. Where, I : Max. leakage current (μA), C : Nominal capacitance (μF), V : Rated voltage (V) (at 20°C after 1 minute)
Dissipation Factor (tanδ)	Rated voltage (V <sub>dc</sub> )
	tanδ (Max.)
Low Temperature Characteristics	When nominal capacitance exceeds 1,000μF, add 0.02 to the value above for each 1,000μF increase. (at 20°C, 120Hz)
	○Leakage current Leakage current at 85°C : ≤10 times of the 20°C specified value ○Max. Impedance Ratio (at 120Hz) Z(-25°C)/Z(+20°C)≤4, Z(-40°C)/Z(+20°C)≤8
Endurance	The following specifications shall be satisfied when the capacitors are restored to 20°C after the rated voltage is applied for 1,000 hours at 85°C.
	Capacitance change
	D.F. (tanδ)
	Leakage current
Shelf Life	The same specifications as "Endurance" shall be satisfied when the capacitors are restored to 20°C after exposing them for 500 hours at 85°C without voltage applied.
Shelf Test	The following specifications shall be satisfied when the capacitors are restored to 20°C after leaving them for 6 months at a nominal temperature (-10 to +40°C) without voltage applied.
	Capacitance change
	D.F. (tanδ)
	Leakage current

◆DIMENSIONS [mm]

●Terminal Code : E

Sleeve (PET : Black)

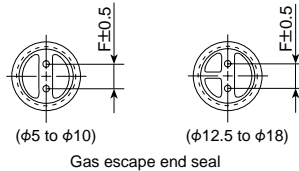
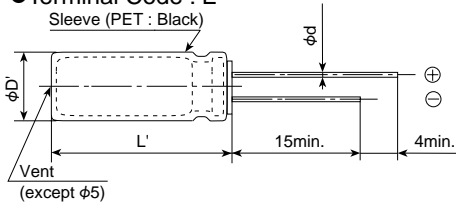

φD	5	6.3	8	10	12.5	16	18
φd	0.5	0.5	0.6	0.6	0.6	0.8	0.8
F	2.0	2.5	3.5	5.0	5.0	7.5	7.5
φD'	φD+0.5max.						
L'	L+1.5max.						

◆PART NUMBERING SYSTEM

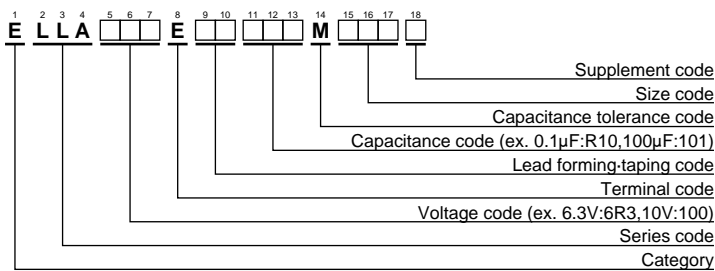

Please refer to "A guide to global code (radial lead type)"

## ◆STANDARD RATINGS

WV (Vdc)	Cap (μF)	Case size φD×L(mm)	tanδ	Rated ripple current (mA <sub>rms</sub> /85°C,120Hz)	Part No.	WV (Vdc)	Cap (μF)	Case size φD×L(mm)	tanδ	Rated ripple current (mA <sub>rms</sub> /85°C,120Hz)	Part No.
6.3	33	5×11	0.24	55	ELLA6R3E□□330ME11D	25	33	5×11	0.14	97	ELLA250E□□330ME11D
	47	5×11	0.24	79	ELLA6R3E□□470ME11D		47	5×11	0.14	115	ELLA250E□□470ME11D
	100	5×11	0.24	130	ELLA6R3E□□101ME11D		100	6.3×11	0.14	190	ELLA250E□□101MF11D
	220	6.3×11	0.24	230	ELLA6R3E□□221MF11D		220	8×11.5	0.14	320	ELLA250E□□221MHB5D
	330	6.3×11	0.24	280	ELLA6R3E□□331MF11D		330	10×12.5	0.14	470	ELLA250E□□331MJC5S
	470	8×11.5	0.24	380	ELLA6R3E□□471MHB5D		470	10×16	0.14	620	ELLA250E□□471MJ16S
	1,000	10×12.5	0.24	650	ELLA6R3E□□102MJC5S		1,000	12.5×20	0.14	1,090	ELLA250E□□102MK20S
	2,200	12.5×20	0.26	1,150	ELLA6R3E□□222MK20S		2,200	16×25	0.16	1,660	ELLA250E□□222ML25S
	3,300	12.5×20	0.28	1,380	ELLA6R3E□□332MK20S		3,300	16×31.5	0.18	2,070	ELLA250E□□332MLN3S
	4,700	16×25	0.30	1,880	ELLA6R3E□□472ML25S		4,700	18×35.5	0.20	2,520	ELLA250E□□472MMP1S
	6,800	16×25	0.34	2,120	ELLA6R3E□□682ML25S		6,800	18×40	0.24	2,830	ELLA250E□□682MM40S
	10,000	16×31.5	0.42	2,500	ELLA6R3E□□103MLN3S		35	4.7	5×11	0.12	40
15,000	18×35.5	0.52	2,990	ELLA6R3E□□153MMP1S	10	5×11		0.12	58	ELLA350E□□100ME11D	
10	22	5×11	0.20	59	ELLA100E□□220ME11D	22		5×11	0.12	87	ELLA350E□□220ME11D
	33	5×11	0.20	84	ELLA100E□□330ME11D	33		5×11	0.12	105	ELLA350E□□330ME11D
	47	5×11	0.20	100	ELLA100E□□470ME11D	47		6.3×11	0.12	145	ELLA350E□□470MF11D
	100	5×11	0.20	145	ELLA100E□□101ME11D	100		8×11.5	0.12	240	ELLA350E□□101MHB5D
	220	6.3×11	0.20	250	ELLA100E□□221MF11D	220		10×12.5	0.12	420	ELLA350E□□221MJC5S
	330	8×11.5	0.20	350	ELLA100E□□331MHB5D	330		10×16	0.12	570	ELLA350E□□331MJ16S
	470	8×11.5	0.20	415	ELLA100E□□471MHB5D	470		10×20	0.12	740	ELLA350E□□471MJ20S
	1,000	10×16	0.20	790	ELLA100E□□102MJ16S	1,000		12.5×25	0.12	1,300	ELLA350E□□102MK25S
	2,200	12.5×20	0.22	1,240	ELLA100E□□222MK20S	2,200		16×31.5	0.14	1,890	ELLA350E□□222MLN3S
	3,300	12.5×25	0.24	1,590	ELLA100E□□332MK25S	3,300		18×35.5	0.16	2,340	ELLA350E□□332MMP1S
	4,700	16×25	0.26	1,980	ELLA100E□□472ML25S	4,700	18×40	0.18	2,690	ELLA350E□□472MM40S	
	6,800	16×31.5	0.30	2,390	ELLA100E□□682MLN3S	50	0.10	5×11	0.10	1.3	ELLA500E□□R10ME11D
10,000	18×35.5	0.38	2,840	ELLA100E□□103MMP1S	0.22		5×11	0.10	2.9	ELLA500E□□R22ME11D	
16	10	5×11	0.16	44	ELLA160E□□100ME11D		0.33	5×11	0.10	4.4	ELLA500E□□R33ME11D
	22	5×11	0.16	75	ELLA160E□□220ME11D		0.47	5×11	0.10	11	ELLA500E□□R47ME11D
	33	5×11	0.16	90	ELLA160E□□330ME11D		1.0	5×11	0.10	17	ELLA500E□□R10ME11D
	47	5×11	0.16	110	ELLA160E□□470ME11D		2.2	5×11	0.10	25	ELLA500E□□R22ME11D
	100	6.3×11	0.16	180	ELLA160E□□101MF11D		3.3	5×11	0.10	35	ELLA500E□□R33ME11D
	220	8×11.5	0.16	300	ELLA160E□□221MHB5D		4.7	5×11	0.10	42	ELLA500E□□R47ME11D
	330	8×11.5	0.16	370	ELLA160E□□331MHB5D		10	5×11	0.10	65	ELLA500E□□100ME11D
	470	10×12.5	0.16	520	ELLA160E□□471MJC5S		22	5×11	0.10	95	ELLA500E□□220ME11D
	1,000	10×20	0.16	910	ELLA160E□□102MJ20S		33	6.3×11	0.10	125	ELLA500E□□330MF11D
	2,200	12.5×25	0.18	1,420	ELLA160E□□222MK25S		47	6.3×11	0.10	150	ELLA500E□□470MF11D
	3,300	16×25	0.20	1,840	ELLA160E□□332ML25S	100	8×11.5	0.10	255	ELLA500E□□101MHB5D	
	4,700	16×31.5	0.22	2,260	ELLA160E□□472MLN3S	220	10×16	0.10	490	ELLA500E□□221MJ16S	
6,800	18×35.5	0.26	2,690	ELLA160E□□682MMP1S	330	10×20	0.10	650	ELLA500E□□331MJ20S		
10,000	18×40	0.34	2,920	ELLA160E□□103MM40S	470	12.5×20	0.10	860	ELLA500E□□471MK20S		
25	4.7	5×11	0.14	31	ELLA250E□□4R7ME11D	1,000	16×25	0.10	1,530	ELLA500E□□102ML25S	
	10	5×11	0.14	54	ELLA250E□□100ME11D	2,200	18×35.5	0.12	2,160	ELLA500E□□222MMP1S	
	22	5×11	0.14	80	ELLA250E□□220ME11D						

□□ : Lead forming / Taping code



◆SPECIFICATIONS

Items	Characteristics						
Category							
Temperature Range	-20 to +55°C						
Rated Voltage Range	300 & 330V <sub>dc</sub>						
Capacitance Tolerance	-10 to +20% (V) (at 20°C, 120Hz)						
Leakage Current	I=1×C Where, I : Max. leakage current (µA), C : Nominal capacitance (µF) (at 20°C after 5 minutes)						
Dissipation Factor (tanδ)	0.06max. (at 20°C, 120Hz)						
Charge and Discharge Characteristics	The following specifications shall be satisfied when the capacitors are restored to 20°C after charge and discharge are repeated 5,000 times at room temperature (5 to 35°C). Discharge resistance or Xenon tube : 0.7 to 1.0Ω. <table border="1"> <tr> <td>Capacitance change</td> <td>≤±10% of the initial value</td> </tr> <tr> <td>D.F. (tanδ)</td> <td>≤150% of the initial specified value</td> </tr> <tr> <td>Leakage current</td> <td>≤150% of the initial specified value</td> </tr> </table>	Capacitance change	≤±10% of the initial value	D.F. (tanδ)	≤150% of the initial specified value	Leakage current	≤150% of the initial specified value
Capacitance change	≤±10% of the initial value						
D.F. (tanδ)	≤150% of the initial specified value						
Leakage current	≤150% of the initial specified value						
Shelf Life	The following specifications shall be satisfied when the capacitors are restored to 20°C after exposing them for 1,000 hours at 55°C without voltage applied. <table border="1"> <tr> <td>Capacitance change</td> <td>≤±10% of the initial value</td> </tr> <tr> <td>D.F. (tanδ)</td> <td>≤150% of the initial specified value</td> </tr> <tr> <td>Leakage current</td> <td>≤150% of the initial specified value</td> </tr> </table>	Capacitance change	≤±10% of the initial value	D.F. (tanδ)	≤150% of the initial specified value	Leakage current	≤150% of the initial specified value
Capacitance change	≤±10% of the initial value						
D.F. (tanδ)	≤150% of the initial specified value						
Leakage current	≤150% of the initial specified value						

◆DIMENSIONS [mm]

●Terminal Code : E

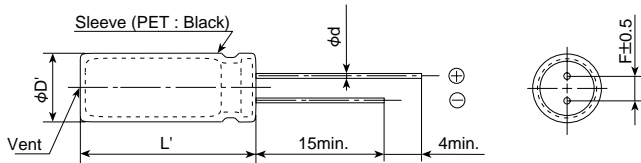

φD	6.0 to 7.5	8.0 to 8.5	9.0 to 9.5	10.0 to 14.0	14.5 to 18
φd	0.5	0.6	0.6	0.6	0.8
F	2.5	3.5	4	5	7.5
φD'	φD+0.5max.				
L'	L+1.0max.				

◆PART NUMBERING SYSTEM

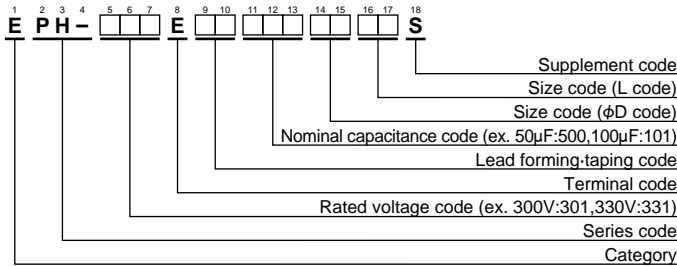

Please refer to "A guide to global code (radial lead type)"

●Size Code

φD code (14th, 15th)

φD(mm)	φD code	
	14th	15th
6.0	6	0
6.5	6	5
7.0	7	0
7.5	7	5
8.0	8	0
8.5	8	5
9.0	9	0
9.5	9	5
10.0	A	0
10.5	A	5
11.0	B	0
11.5	B	5
12.0	C	0
12.5	C	5
13.0	D	0
13.5	D	5
14.0	E	0
14.5	E	5
15.0	F	0
15.5	F	5
16.0	G	0
16.5	G	5
17.0	H	0
17.5	H	5
18.0	J	0

L code (16th, 17th)

L(mm)	L code	
	16th	17th
15.0	1	5
16.0	1	6
17.0	1	7
18.0	1	8
19.0	1	9
20.0	2	0
21.0	2	1
22.0	2	2
23.0	2	3
24.0	2	4
25.0	2	5
26.0	2	6
27.0	2	7
28.0	2	8
29.0	2	9
30.0	3	0
31.0	3	1
32.0	3	2
33.0	3	3
34.0	3	4
35.0	3	5
36.0	3	6
37.0	3	7
38.0	3	8
39.0	3	9
40.0	4	0
41.0	4	1
42.0	4	2
43.0	4	3
44.0	4	4
45.0	4	5

## Appendix (Global code)

### ◆Capacitance code

\* How to use the table

	1st
2nd	Cap. Value

Capacitance value part

2nd	1st								
	1	2	3	4	5	6	7	8	9
0	10.0	20.0	30.0	40.0	50.0	60.0	70.0	80.0	90.0
A	10.5	20.5	30.5	40.5	50.5	60.5	70.5	80.5	90.5
1	11.0	21.0	31.0	41.0	51.0	61.0	71.0	81.0	91.0
B	11.5	21.5	31.5	41.5	51.5	61.5	71.5	81.5	91.5
2	12.0	22.0	32.0	42.0	52.0	62.0	72.0	82.0	92.0
C	12.5	22.5	32.5	42.5	52.5	62.5	72.5	82.5	92.5
3	13.0	23.0	33.0	43.0	53.0	63.0	73.0	83.0	93.0
D	13.5	23.5	33.5	43.5	53.5	63.5	73.5	83.5	93.5
4	14.0	24.0	34.0	44.0	54.0	64.0	74.0	84.0	94.0
E	14.5	24.5	34.5	44.5	54.5	64.5	74.5	84.5	94.5
5	15.0	25.0	35.0	45.0	55.0	65.0	75.0	85.0	95.0
F	15.5	25.5	35.5	45.5	55.5	65.5	75.5	85.5	95.5
6	16.0	26.0	36.0	46.0	56.0	66.0	76.0	86.0	96.0
G	16.5	26.5	36.5	46.5	56.5	66.5	76.5	86.5	96.5
7	17.0	27.0	37.0	47.0	57.0	67.0	77.0	87.0	97.0
H	17.5	27.5	37.5	47.5	57.5	67.5	77.5	87.5	97.5
8	18.0	28.0	38.0	48.0	58.0	68.0	78.0	88.0	98.0
J	18.5	28.5	38.5	48.5	58.5	68.5	78.5	88.5	98.5
9	19.0	29.0	39.0	49.0	59.0	69.0	79.0	89.0	99.0
K	19.5	29.5	39.5	49.5	59.5	69.5	79.5	89.5	99.5

For less than 10 $\mu$ F, a decimal point position is displayed with R.

For 10 $\mu$ F or more, capacitance code is set to the first 2 digits and index (1digit).

Treatment of fraction (Refer to the table)

Example of conversion

Real cap.	The first 2 digits	Treatment of fraction	Code		
			11th	12th	13th
10.0 $\mu$ F →	10.0 →	10.0 →	1	0	0
10.1 $\mu$ F →	10.1 →	10.0 →	1	0	0
10.2 $\mu$ F →	10.2 →	10.0 →	1	0	0
10.3 $\mu$ F →	10.3 →	10.5 →	1	A	0
10.4 $\mu$ F →	10.4 →	10.5 →	1	A	0
10.5 $\mu$ F →	10.5 →	10.5 →	1	A	0
10.6 $\mu$ F →	10.6 →	10.5 →	1	A	0
10.7 $\mu$ F →	10.7 →	10.5 →	1	A	0
10.8 $\mu$ F →	10.8 →	11.0 →	1	1	0
10.9 $\mu$ F →	10.9 →	11.0 →	1	1	0
11.0 $\mu$ F →	11.0 →	11.0 →	1	1	0
132 $\mu$ F →	13.2 →	13.0 →	1	3	1
133 $\mu$ F →	13.3 →	13.5 →	1	D	1
167 $\mu$ F →	16.7 →	16.5 →	1	G	1
168 $\mu$ F →	16.8 →	17.0 →	1	7	1
1110 $\mu$ F →	11.1 →	11.0 →	1	1	2
1340 $\mu$ F →	13.4 →	13.5 →	1	D	2
13200 $\mu$ F →	13.2 →	13.0 →	1	3	3
13600 $\mu$ F →	13.6 →	13.5 →	1	D	3
270000 $\mu$ F →	27.0 →	27.0 →	2	7	4

### ◆Case length (Radial lead type)

Case length [mm]	16th	17th	Case length [mm]	16th	17th	Case length [mm]	16th	17th	Case length [mm]	16th	17th	Case length [mm]	16th	17th	Case length [mm]	16th	17th
0.0	—	—	1.0	0	1	2.0	0	2	3.0	0	3	4.0	0	4			
0.1	0	B	1.1	1	B	2.1	2	B	3.1	3	B	4.1	4	B			
0.2	0	C	1.2	1	C	2.2	2	C	3.2	3	C	4.2	4	C			
0.3	0	D	1.3	1	D	2.3	2	D	3.3	3	D	4.3	4	D			
0.4	0	E	1.4	1	E	2.4	2	E	3.4	3	E	4.4	4	E			
0.5	0	F	1.5	1	F	2.5	2	F	3.5	3	F	4.5	4	F			
0.6	0	G	1.6	1	G	2.6	2	G	3.6	3	G	4.6	4	G			
0.7	0	H	1.7	1	H	2.7	2	H	3.7	3	H	4.7	4	H			
0.8	0	J	1.8	1	J	2.8	2	J	3.8	3	J	4.8	4	J			
0.9	0	K	1.9	1	K	2.9	2	K	3.9	3	K	4.9	4	K			
5.0	0	5	6.0	0	6	7.0	0	7	8.0	0	8	9.0	0	9			
5.1	5	B	6.1	6	B	7.1	7	B	8.1	8	B	9.1	9	B			
5.2	5	C	6.2	6	C	7.2	7	C	8.2	8	C	9.2	9	C			
5.3	5	D	6.3	6	D	7.3	7	D	8.3	8	D	9.3	9	D			
5.4	5	E	6.4	6	E	7.4	7	E	8.4	8	E	9.4	9	E			
5.5	5	F	6.5	6	F	7.5	7	F	8.5	8	F	9.5	9	F			
5.6	5	G	6.6	6	G	7.6	7	G	8.6	8	G	9.6	9	G			
5.7	5	H	6.7	6	H	7.7	7	H	8.7	8	H	9.7	9	H			
5.8	5	J	6.8	6	J	7.8	7	J	8.8	8	J	9.8	9	J			
5.9	5	K	6.9	6	K	7.9	7	K	8.9	8	K	9.9	9	K			
10.0	1	0	11.0	1	1	12.0	1	2	13.0	1	3	14.0	1	4			
10.1	A	1	11.1	B	1	12.1	C	1	13.1	D	1	14.1	E	1			
10.2	A	2	11.2	B	2	12.2	C	2	13.2	D	2	14.2	E	2			
10.3	A	3	11.3	B	3	12.3	C	3	13.3	D	3	14.3	E	3			
10.4	A	4	11.4	B	4	12.4	C	4	13.4	D	4	14.4	E	4			
10.5	A	5	11.5	B	5	12.5	C	5	13.5	D	5	14.5	E	5			
10.6	A	6	11.6	B	6	12.6	C	6	13.6	D	6	14.6	E	6			
10.7	A	7	11.7	B	7	12.7	C	7	13.7	D	7	14.7	E	7			
10.8	A	8	11.8	B	8	12.8	C	8	13.8	D	8	14.8	E	8			
10.9	A	9	11.9	B	9	12.9	C	9	13.9	D	9	14.9	E	9			





# PART NUMBERING SYSTEM

Case length [mm]	16th	17th
15.0	1	5
15.1	F	1
15.2	F	2
15.3	F	3
15.4	F	4
15.5	F	5
15.6	F	6
15.7	F	7
15.8	F	8
15.9	F	9

Case length [mm]	16th	17th
16.0	1	6
16.1	G	1
16.2	G	2
16.3	G	3
16.4	G	4
16.5	G	5
16.6	G	6
16.7	G	7
16.8	G	8
16.9	G	9

Case length [mm]	16th	17th
17.0	1	7
17.1	H	1
17.2	H	2
17.3	H	3
17.4	H	4
17.5	H	5
17.6	H	6
17.7	H	7
17.8	H	8
17.9	H	9

Case length [mm]	16th	17th
18.0	1	8
18.1	J	1
18.2	J	2
18.3	J	3
18.4	J	4
18.5	J	5
18.6	J	6
18.7	J	7
18.8	J	8
18.9	J	9

Case length [mm]	16th	17th
19.0	1	9
19.1	K	1
19.2	K	2
19.3	K	3
19.4	K	4
19.5	K	5
19.6	K	6
19.7	K	7
19.8	K	8
19.9	K	9

Case length [mm]	16th	17th
20.0	2	0
20.5	L	1
21.0	2	1
21.5	L	3
22.0	2	2
22.5	L	5
23.0	2	3
23.5	L	7
24.0	2	4
24.5	L	9
25.0	2	5
25.5	M	1
26.0	2	6
26.5	M	3
27.0	2	7
27.5	M	5
28.0	2	8
28.5	M	7
29.0	2	9
29.5	M	9

Case length [mm]	16th	17th
30.0	3	0
30.5	N	1
31.0	3	1
31.5	N	3
32.0	3	2
32.5	N	5
33.0	3	3
33.5	N	7
34.0	3	4
34.5	N	9
35.0	3	5
35.5	P	1
36.0	3	6
36.5	P	3
37.0	3	7
37.5	P	5
38.0	3	8
38.5	P	7
39.0	3	9
39.5	P	9

Case length [mm]	16th	17th
40.0	4	0
40.5	Q	1
41.0	4	1
41.5	Q	3
42.0	4	2
42.5	Q	5
43.0	4	3
43.5	Q	7
44.0	4	4
44.5	Q	9
45.0	4	5
45.5	R	1
46.0	4	6
46.5	R	3
47.0	4	7
47.5	R	5
48.0	4	8
48.5	R	7
49.0	4	9
49.5	R	9

Case length [mm]	16th	17th
50.0	5	0
50.5	S	1
51.0	5	1
51.5	S	3
52.0	5	2
52.5	S	5
53.0	5	3
53.5	S	7
54.0	5	4
54.5	S	9
55.0	5	5
55.5	T	1
56.0	5	6
56.5	T	3
57.0	5	7
57.5	T	5
58.0	5	8
58.5	T	7
59.0	5	9
59.5	T	9

Case length [mm]	16th	17th
60.0	6	0
60.5	U	1
61.0	6	1
61.5	U	3
62.0	6	2
62.5	U	5
63.0	6	3
63.5	U	7
64.0	6	4
64.5	U	9
65.0	6	5
65.5	V	1
66.0	6	6
66.5	V	3
67.0	6	7
67.5	V	5
68.0	6	8
68.5	V	7
69.0	6	9
69.5	V	9

Case length [mm]	16th	17th
70.0	7	0
70.5	W	1
71.0	7	1
71.5	W	3
72.0	7	2
72.5	W	5
73.0	7	3
73.5	W	7
74.0	7	4
74.5	W	9
75.0	7	5
75.5	X	1
76.0	7	6
76.5	X	3
77.0	7	7
77.5	X	5
78.0	7	8
78.5	X	7
79.0	7	9
79.5	X	9

Case length [mm]	16th	17th
80.0	8	0
80.5	Y	1
81.0	8	1
81.5	Y	3
82.0	8	2
82.5	Y	5
83.0	8	3
83.5	Y	7
84.0	8	4
84.5	Y	9
85.0	8	5
85.5	Z	1
86.0	8	6
86.5	Z	3
87.0	8	7
87.5	Z	5
88.0	8	8
88.5	Z	7
89.0	8	9
89.5	Z	9

## ◆Case length (Snap-in type / Screw mount terminal type)

Case length [mm]	16th	17th	Case length [mm]	16th	17th	Case length [mm]	16th	17th	Case length [mm]	16th	17th	Case length [mm]	16th	17th
20	2	0	30	3	0	40	4	0	50	5	0	60	6	0
21	2	1	31	3	1	41	4	1	51	5	1	61	6	1
22	2	2	32	3	2	42	4	2	52	5	2	62	6	2
23	2	3	33	3	3	43	4	3	53	5	3	63	6	3
24	2	4	34	3	4	44	4	4	54	5	4	64	6	4
25	2	5	35	3	5	45	4	5	55	5	5	65	6	5
26	2	6	36	3	6	46	4	6	56	5	6	66	6	6
27	2	7	37	3	7	47	4	7	57	5	7	67	6	7
28	2	8	38	3	8	48	4	8	58	5	8	68	6	8
29	2	9	39	3	9	49	4	9	59	5	9	69	6	9
70	7	0	80	8	0	90	9	0	100	A	0	110	B	0
71	7	1	81	8	1	91	9	1	101	A	1	111	B	1
72	7	2	82	8	2	92	9	2	102	A	2	112	B	2
73	7	3	83	8	3	93	9	3	103	A	3	113	B	3
74	7	4	84	8	4	94	9	4	104	A	4	114	B	4
75	7	5	85	8	5	95	9	5	105	A	5	115	B	5
76	7	6	86	8	6	96	9	6	106	A	6	116	B	6
77	7	7	87	8	7	97	9	7	107	A	7	117	B	7
78	7	8	88	8	8	98	9	8	108	A	8	118	B	8
79	7	9	89	8	9	99	9	9	109	A	9	119	B	9
120	C	0	130	D	0	140	E	0	150	F	0	160	G	0
121	C	1	131	D	1	141	E	1	151	F	1	161	G	1
122	C	2	132	D	2	142	E	2	152	F	2	162	G	2
123	C	3	133	D	3	143	E	3	153	F	3	163	G	3
124	C	4	134	D	4	144	E	4	154	F	4	164	G	4
125	C	5	135	D	5	145	E	5	155	F	5	165	G	5
126	C	6	136	D	6	146	E	6	156	F	6	166	G	6
127	C	7	137	D	7	147	E	7	157	F	7	167	G	7
128	C	8	138	D	8	148	E	8	158	F	8	168	G	8
129	C	9	139	D	9	149	E	9	159	F	9	169	G	9
170	H	0	180	J	0	190	K	0	200	L	0	210	M	0
171	H	1	181	J	1	191	K	1	201	L	1	211	M	1
172	H	2	182	J	2	192	K	2	202	L	2	212	M	2
173	H	3	183	J	3	193	K	3	203	L	3	213	M	3
174	H	4	184	J	4	194	K	4	204	L	4	214	M	4
175	H	5	185	J	5	195	K	5	205	L	5	215	M	5
176	H	6	186	J	6	196	K	6	206	L	6	216	M	6
177	H	7	187	J	7	197	K	7	207	L	7	217	M	7
178	H	8	188	J	8	198	K	8	208	L	8	218	M	8
179	H	9	189	J	9	199	K	9	209	L	9	219	M	9
220	N	0	230	P	0	240	Q	0	250	R	0			
221	N	1	231	P	1	241	Q	1	251	R	1			
222	N	2	232	P	2	242	Q	2	252	R	2			
223	N	3	233	P	3	243	Q	3	253	R	3			
224	N	4	234	P	4	244	Q	4	254	R	4			
225	N	5	235	P	5	245	Q	5	255	R	5			
226	N	6	236	P	6	246	Q	6	256	R	6			
227	N	7	237	P	7	247	Q	7	257	R	7			
228	N	8	238	P	8	248	Q	8	258	R	8			
229	N	9	239	P	9	249	Q	9	259	R	9			

## ◆ Supplement code

### Surface mount type / Conductive polymer (Include Radial lead type)

	Terminal plating material (Radial lead type)		
	Sn100%	Sn-Bi	Sn-Pb
Coating case	S	G	N

### Radial lead type / Snap-in type

		Terminal plating material (Radial lead type)		
		Sn100%	Sn-Bi	Sn-Pb
Outer sleeve	PET	S	D	C
	Coating case	H	G	F
	Polyolefin	L	—	—
	Pb-free PVC	M	—	N
	PVC	B	A	N

\* Pb-free snap-in type does not have top disk.

We also produce Pb-free snap-in type with "Top disk, Pb-free PVC sleeve and Sn100% terminal plating".  
In this case, supplement code (the 18th digit) becomes "T".

### Screw mount terminal type

	Screw terminal
Pb-free PVC	M
Polyolefin	S
PET	C
PVC	N